

TRANSTECNO[®]
the modular gearmotor

SM..UL

SM..UL



C **RU** **US**
File E511911

Motori elettrici asincroni CA
AC asynchronous electric motors



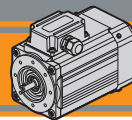

Indice	Index	Pag. Page
Caratteristiche tecniche	<i>Technical features</i>	Q2
Designazione	<i>Classification</i>	Q2
Simbologia e formule	<i>Symbols and formulas</i>	Q3
Dati tecnici	<i>Technical data</i>	Q3
Dimensioni motori trifase	<i>Three phase motors dimensions</i>	Q4
Dimensioni motori monofase	<i>Single phase motors dimensions</i>	Q7
Cava esagonale	<i>Hexagonal socket</i>	Q9
Versioni opzionali	<i>Optional versions</i>	Q9
Opzione guarnizione CA	<i>Rubber gasket option</i>	Q9
Certificazione UL / CSA	<i>UL / CSA certificate</i>	Q9
Gradi di protezione IP	<i>IP protection rating</i>	Q10
Tipo di servizio IEC	<i>IEC duty cycles</i>	Q11
Tabella pressacavi	<i>Table of cable glands data</i>	Q11
Connessioni e collegamenti	<i>Connection diagram</i>	Q12
Targhetta	<i>Nameplate</i>	Q15

Questa sezione annulla e sostituisce ogni precedente edizione o revisione. Qualora questa sezione non Vi sia giunta in distribuzione controllata, l'aggiornamento dei dati ivi contenuto non è assicurato. **In tal caso la versione più aggiornata è disponibile sul nostro sito internet www.transtecno.com**

This section replaces any previous edition and revision. If you obtained this catalogue other than through controlled distribution channels, the most up to date content is not guaranteed. In this case the latest version is available on our web site www.transtecno.com

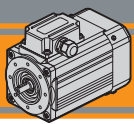

Caratteristiche tecniche

Technical characteristics

I motori certificati UL/CSA delle serie SMT ed SMM hanno le seguenti caratteristiche principali:

SMT and SMM motor range with UL/CSA Certification has the following main features:

- Costruzione compatta
- Motorizzazioni in corrente alternata monofase e trifase
- Carcassa estrusa in alluminio anodizzato nero
- Motore elettrico CA con grado di protezione IP66 (escluso condensatore)
- Rumorosità e vibrazioni contenute
- Isolamento termico di classe F
- Flangia motore IEC B14
- Temperatura ambiente: -20°C/+40°C
- Disponibili nella versione ventilata TEFC (servizio S1).
- Protezione termica PTO 150°C
- Motori trifase SMT dotati di separatori di fase
- Cava esagonale su albero motore lato NDE
- Condensatore di marcia per motori monofase SMM
- La tolleranza di tensione è ±10%
- Standard applicati:
UL1004-1: Rotating Electrical Machines General Requirements
CSA:100-14: Motors and Generators

- Compact design
- AC single phase and three phase motors available
- Black anodized extruded aluminium housing
- AC electric motor in IP66 protection Standard (except capacitor)
- Low noise and vibrations
- Class F insulation Standard
- Motor flange IEC B14
- Ambient temperature: -20°C / +40°C
- Fan cooled TEFC (duty S1)
- PTO 150°C thermal protection
- Three phase motors SMT equipped with phase separators.
- Motor shaft hexagon socket on the NDE side.
- Running capacitor for single phase motors SMM.
- Voltage tolerance ±10%
- Standards applied:
UL1004-1: Rotating Electrical Machines General Requirements
CSA:100-14: Motors and Generators

SM .. UL/CSA

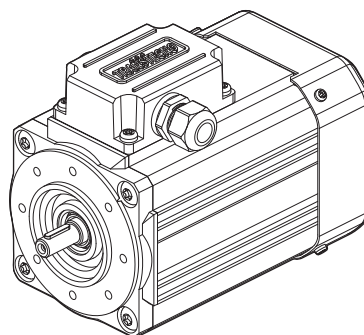



UL US
File E511911



Designazione

Classification

MOTORE TRIFASE / THREE PHASE MOTOR									
SMT	63	2	4	0.18 kW	B14	230-400 V	50 Hz	TEFC	UL-CSA
Tipo Type	Grandezza Size	Indicativo potenza Power coefficient	Poli Poles	Potenza Power	Forma costruttiva Version	Tensione Voltage	Frequenza Frequency	Ventilazione Fan cooling	Versione UL UL Version
SMT  3 ~	Vedi tabelle See tables	2 - 3	4	0.09 kW ... 1.8 kW	B14	230-400 V 460V	50Hz 60Hz	TEFC	UL-CSA
MOTORE MONOFASE / SINGLE PHASE MOTOR									
SMM	63	2	4	0.18 kW	B14	115 V	60 Hz	TEFC	UL-CSA
Tipo Type	Grandezza Size	Indicativo potenza Power coefficient	Poli Poles	Potenza Power	Forma costruttiva Version	Tensione Voltage	Frequenza Frequency	Ventilazione Fan cooling	Versione UL UL Version
SMM  1 ~	Vedi tabelle See tables	2 - 3	4	0.09 kW ... 0.37 kW	B14	115V	60Hz	TEFC	UL-CSA

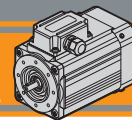
Simbologia e formule
Symbols and formulas

P_n	[kW]	Potenza nominale	Rated power
I_n	[A]	Corrente nominale	Rated current
M_n	[Nm]	Coppia nominale	Rated torque
n_n	[rpm]	Velocità nominale	Rated speed
M_s / M_n		Rapporto coppia spunto / coppia nominale	Ratio start torque / rated torque
M_k / M_n		Rapporto coppia massima / coppia nominale	Ratio max torque / rated torque
I_s / I_n		Rapporto corrente di spunto / corrente nominale	Ratio start current / rated current
$\cos\varphi$		Fattore di potenza al carico nominale	Power factor at rated torque load
η		Rendimento al carico nominale	Efficiency at rated torque load
f	[Hz]	Frequenza	Frequency
V	[V]	Tensione	Voltage
Potenza Power	[HP]	Potenza [kW] x 1.341	Power [kW] x 1.341
Potenza resa P_n P_n output power	[kW]	Potenza assorbita x η	Absorbed power x η
Pot. assorbita Absorbed power	[kW]	$\frac{V \times I \times \cos\varphi}{1000}$ (monofase)	$\frac{V \times I \times \cos\varphi}{1000}$ (singlephase)
		$\frac{V \times I \times \sqrt{3} \times \cos\varphi}{1000}$ (trifase)	$\frac{V \times I \times \sqrt{3} \times \cos\varphi}{1000}$ (threephase)
I_n (230 V)		I_n (400 V) x $\sqrt{3}$	I_n (400 V) x $\sqrt{3}$

Dati tecnici
Technical data
SMT Motori trifase / SMT Three phase motors

(230-400 V / 50 Hz) poli / poles 4

(460 V / 60 Hz) poli / poles 4

TAGLIA SIZE	P_n [kW]	M_n [Nm]	n_n [min ⁻¹]	V - f [V - Hz]	I_n (400-460 V) [A]	η %	$\cos\varphi$	M_s/M_n	I_s/I_n	M_k/M_n	PTO [°C]	Servizio Duty TEFC
5624	0.09	0.63	1365	400 - 50	0.45	47.3	0.61	2.50	2.40	2.70	PTO 150°	S1
	0.11		1660	460 - 60		50.3		2.60	2.60			
5634	0.12	0.88	1300	400 - 50	0.45	52.0	0.74	1.90	2.40	1.90		
	0.14	0.83	1600	460 - 60	0.42	59.0	0.71	2.10	2.70	2.10		
6324	0.18	1.26	1360	400 - 50	0.69	57.0	0.66	2.50	2.90	2.50		
	0.22	1.27	1650	460 - 60		59.7	0.67		3.00			
6334	0.25	1.74	1375	400 - 50	0.94	62.0	0.64	2.80	3.00	2.80		
	0.28	1.59	1690	460 - 60		61.3	0.61	3.00	3.20	3.00		
7124	0.37	2.52	1400	400 - 50	1.09	68.0	0.72	2.75	4.20	2.75		
	0.42	2.35	1700	460 - 60		68.1	0.71	2.90	4.50	2.90		
7134	0.55	3.76	1395	400 - 50	1.55	70.2	0.73	2.90	4.40	2.90		
	0.66	3.71	1700	460 - 60		73.2			4.80	2.80		
8024	0.75	4.96	1440	400 - 50	1.97	82.0	0.67	3.60	6.00	3.70		
	0.90	4.93	1740	460 - 60		84.3	0.68	3.40	6.40	3.60		
8034	1.10	7.25	1450	400 - 50	2.92	83.6	0.65	4.0	6.80	4.40		
	1.21	6.65	1740	460 - 60		77.6	0.67	4.4	7.00	4.50		
9024	1.50	10.0	1430	400 - 50	3.48	85.2	0.73	3.2	6.30	3.50		
	1.80	9.88	1740	460 - 60		85.4	0.76	3.4	6.50	3.40		

SMM Motori monofase / SMM Single phase motors

(115 V / 60 Hz) poli / poles 4

TAGLIA SIZE	P_n [kW]	M_n [Nm]	n_n [min ⁻¹]	V - f [V - Hz]	I_n (115V) [A]	η %	$\cos\varphi$	M_s/M_n	I_s/I_n	M_k/M_n	Cond/cap [μF]	PTO [°C]	Servizio Duty TEFC
5624	0.09	0.52	1665	115 - 60	1.60	50.0	0.98	0.64	1.95	1.51	20	PTO 150°	S1
6324	0.18	1.09	1570	115 - 60	2.70	58.5	0.99	1.0	2.1	1.50	40		
7124	0.37	2.18	1620	115 - 60	4.70	69.8	0.98	0.64	2.3	1.33	60		



Dimensioni motori trifase

Three phase motors dimensions

3~

SMT56.. - B14 - TEFC

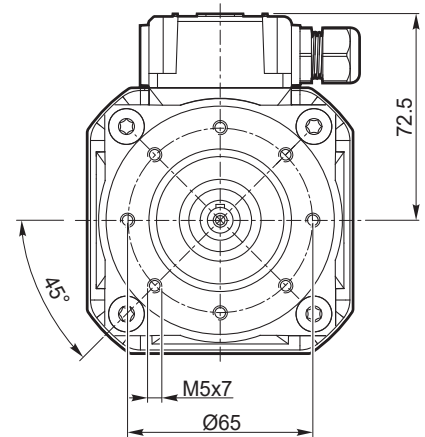
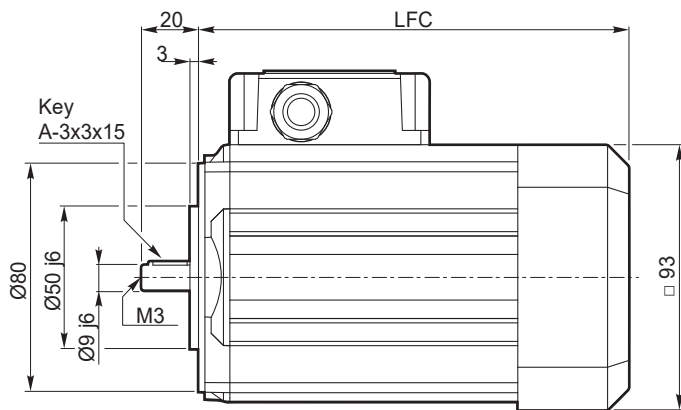

SMT	... TEFC	
	LFC	Kg
5624	186	3.1
5634	186	3.5

3~

SMT63.. - B14 - TEFC

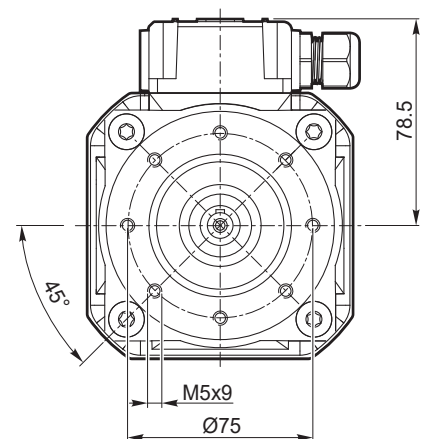
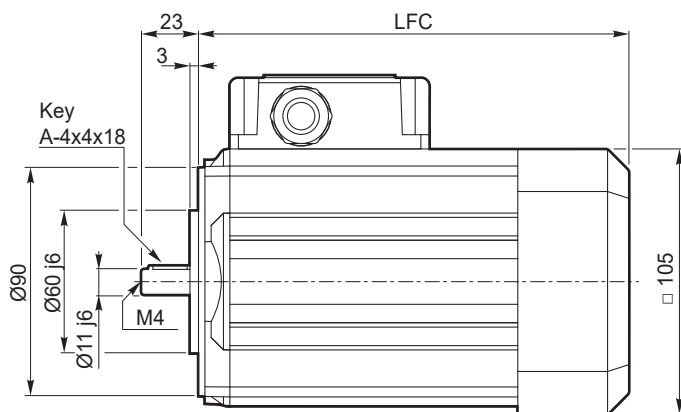

SMT	... TEFC	
	LFC	Kg
6324	205.5	4.7
6334	205.5	5.4

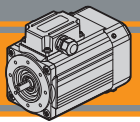

Dimensioni motori trifase

Three phase motors dimensions

3 ~

SMT71.. - B14 - TEFC

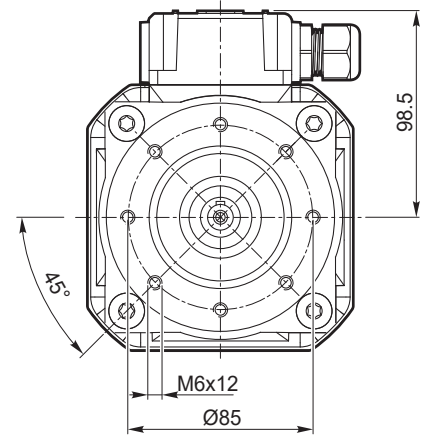
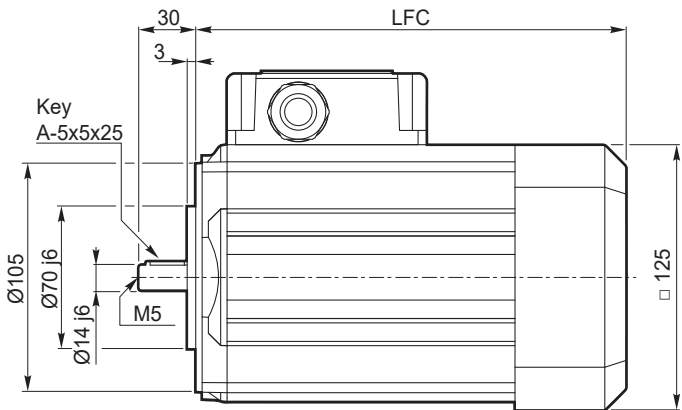

SMT	... TEFC	
	LFC	Kg
7124	214	7.0
7134	214	8.2

3 ~

SMT80.. - B14 - TEFC

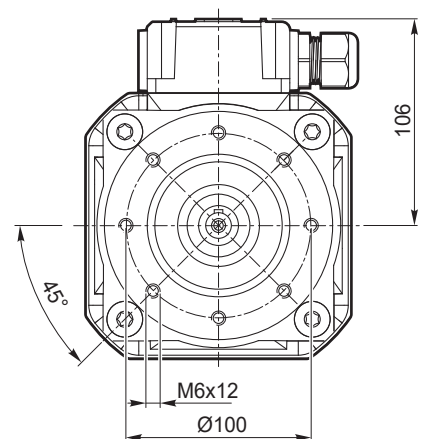
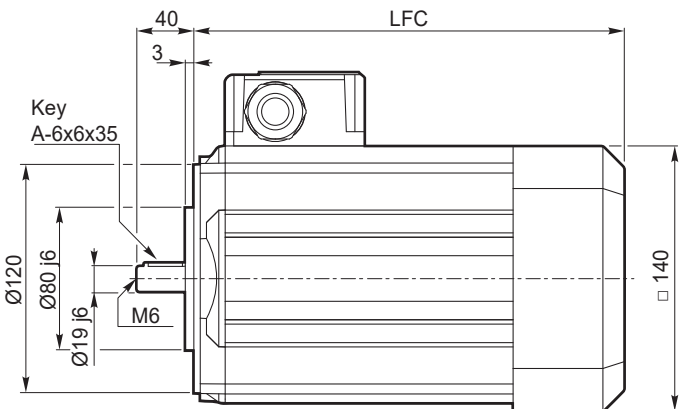

SMT	... TEFC	
	LFC	Kg
8024	283	12.8
8034	309	17.1



Dimensioni motori trifase

Three phase motors dimensions

3~

SMT90.. - B14 - TEFC

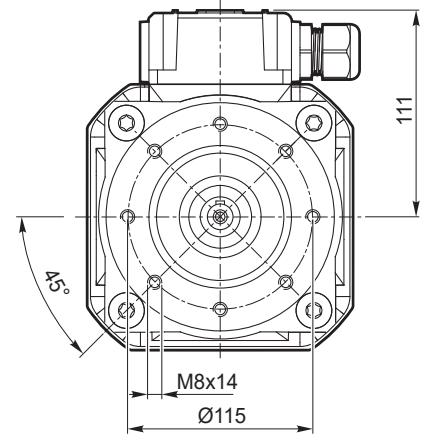
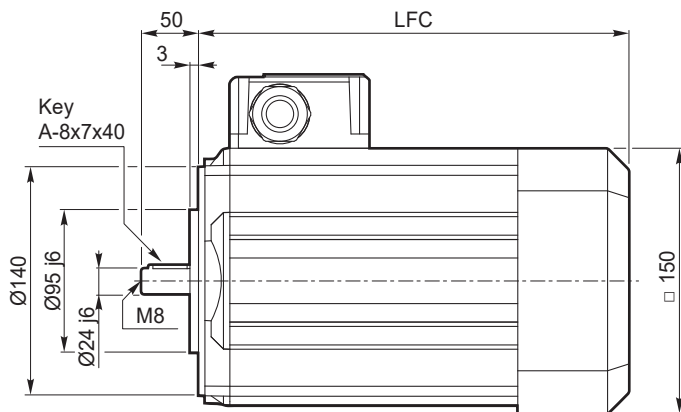

SMT	... TEFC	
	LFC	Kg
9024	313	18.5

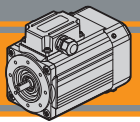

Dimensioni motori monofase

Single phase motors dimensions

1 ~

SMM56.. - B14 - TEFC

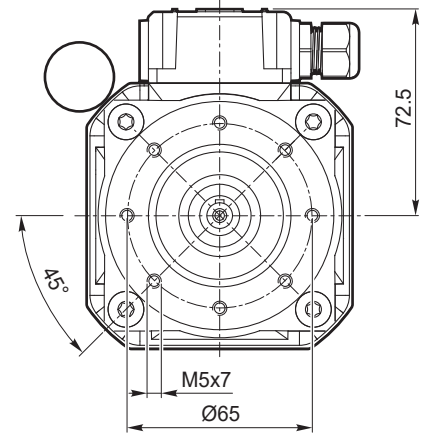
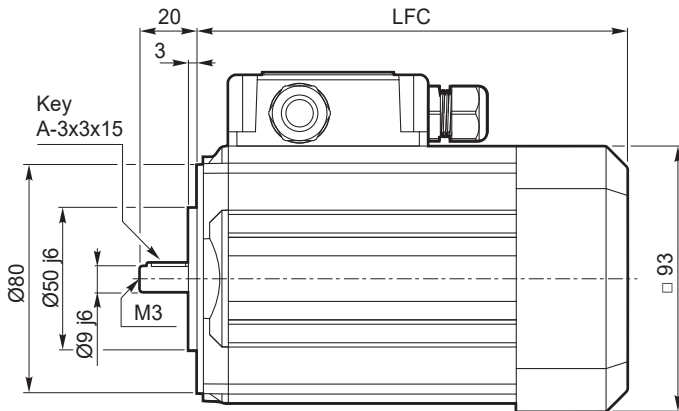

SMM	... TEFC	
	LFC	Kg
5624	186	3.6

1 ~

SMM63.. - B14 - TEFC

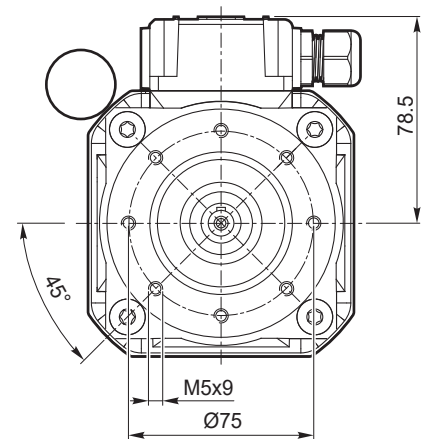
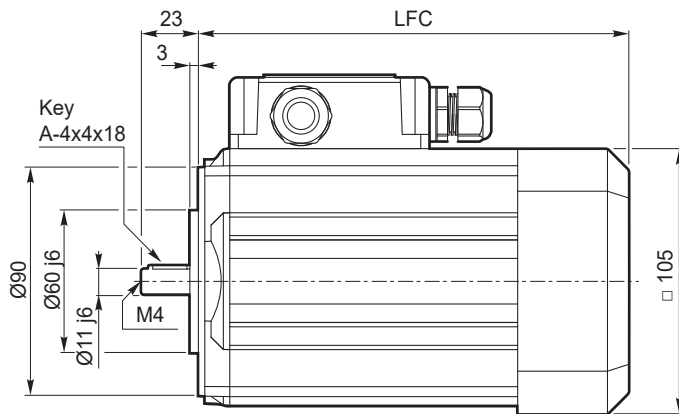

SMM	... TEFC	
	LFC	Kg
6324	205.5	5.5

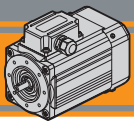

1 ~

SMM71.. - B14 - TEFC

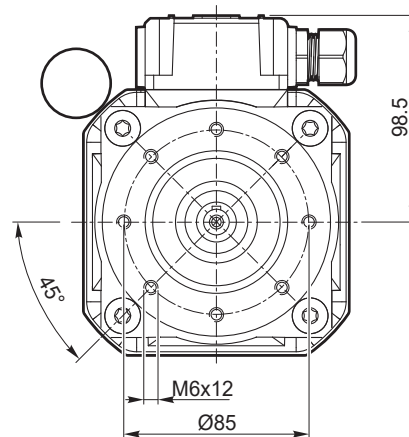
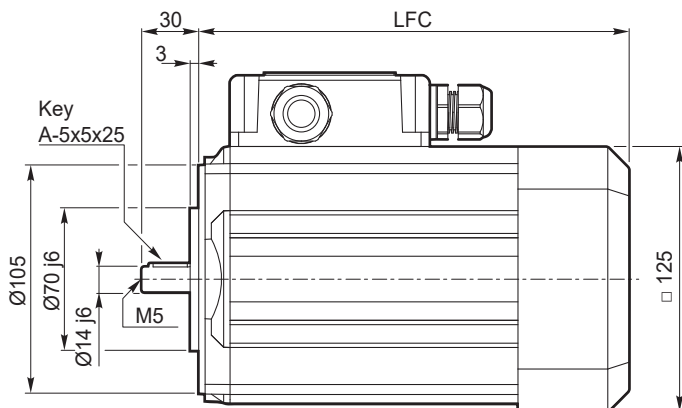

SMM	... TEFC	
	LFC	kg
7124	214	8.0

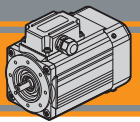
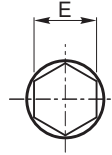
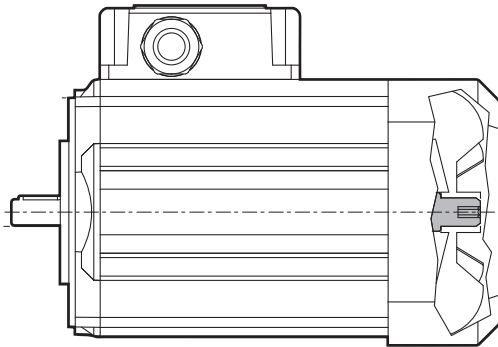
Cava esagonale
Hexagonal socket

Esagono / Hexagon

SM..	E
56	4
63	
71	
80	6
90	

Nota:

Installare a monte dell'alimentazione un dispositivo che assicuri la disconnessione della rete omipolare, durante le operazioni di rotazione manuale è obbligatorio l'utilizzo di tale sezionatore.

Il quadro elettrico del motore deve essere lucchettabile al fine di evitare il riarmo non previsto alla rete elettrica.

E' severamente vietata la messa in servizio del motore elettrico senza copriventola opportunamente montata.

Note:

An omnipolar cut-off device must be fitted upstream of the power supply; the use of this device is mandatory during manual rotation operations.

The switchgear for the motor must be padlockable in order to prevent the power supply from being accidentally reset. It is strictly prohibited to put the electric motor into service if the fan cover is not fitted.

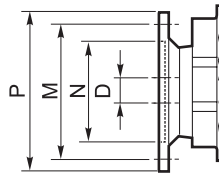
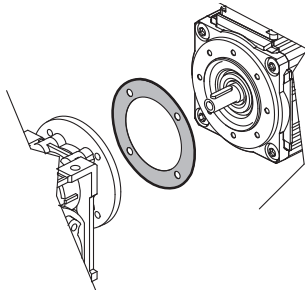
Opzione guarnizione CA
Rubber gasket option

Dimensioni IEC / IEC Dimensions

	56 B14	63 B14	71 B14	80 B14	90 B14
N	50	60	70	80	95
M	65	75	85	100	115
P	80	90	105	120	140
D	9	11	14	19	24

Versioni opzionali
Optional versions

Versioni opzionali con freno ed encoder disponibili a richiesta su alcuni modelli. Su richiesta sono disponibili grandezze motore superiori a quelle indicate a catalogo.

Si prega di contattare il nostro Servizio Tecnico.

Optional versions with brake and encoder are available on request on some models. Motor sizes bigger than those indicated in the catalogue are available on request.

Please contact our Technical Service.

Certificazione UL / CSA
UL / CSA certificate

I motori SM certificati UL/CSA sono marcati secondo la Norma UL 1004-1, Rotating Electrical Machines General Requirements e CSA 100-14, Motors and Generators.

SM motors Certified UL/CSA are marked for approval by UL 1004-1, Rotating Electrical Machines General Requirements and CSA 100-14, Motors and Generators.

**Grado di protezione IP****IP protection rating**

Indica il grado di isolamento meccanico del corpo motore.















1^a cifra protezione alla penetrazione di corpi solidi.

2^a cifra protezione contro la penetrazione d'acqua.

IP protection rating indicates the degree of mechanical insulation of the motor casing.

The 1st figure indicates the level of protection against the intrusion of solid matter.

The 2nd figure indicates to which degree the motor is waterproof.

IP		Definizione / Description	IP		Definizione / Description
0		Non protetto / No protection	0		Non protetto / No protection
1		Protetto da corpi solidi superiori a Ø 50 mm. <i>Protected against solid matter (over Ø 50 mm).</i>	1		Protetto contro la caduta verticale di gocce d'acqua. <i>Protected against drops of water falling vertically.</i>
2		Protetto da corpi solidi superiori a Ø 12 mm. <i>Protected against solid matter (over Ø 12 mm).</i>	2		Protetto contro la caduta verticale di gocce d'acqua con inclinazione max di 15°. <i>Protected against drops of water falling up to 15°.</i>
3		Protetto da corpi solidi superiori a Ø 2.5 mm. <i>Protected against solid matter (over Ø 2.5 mm).</i>	3		Protetto contro la pioggia. <i>Rain proof.</i>
4		Protetto da corpi solidi superiori a Ø 1 mm. <i>Protected against solid matter (over Ø 1 mm).</i>	4		Protetto contro gli spruzzi. <i>Splash proof.</i>
5		Protetto contro la polvere. <i>Dust protected.</i>	5		Protetto contro getti d'acqua. <i>Water jet proof.</i>
6		Totalmente protetto contro la polvere. <i>Fully dust tight.</i>	6		Protetto dalle ondate. <i>Waveproof.</i>
7		N.A.	7		Protetto contro immersione. <i>Immersion up to 1 metre.</i>
8		N.A.	8		Protetto contro immersione/sommersione prolungata. <i>Immersion beyond 1 metre.</i>

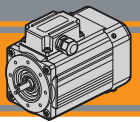
Tipi di servizi IEC
IEC duty cycles

Il servizio di un motore indica il tipo di utilizzo e la gravosità del ciclo di lavoro.

The duty cycle of a motor indicates its use and running cycle.

Grafico servizi più comuni

Most common duty cycles diagram

N = funzionamento / run
 R = riposo / rest

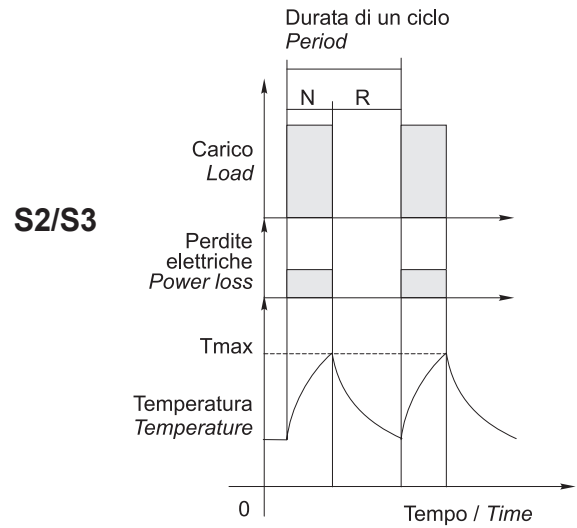
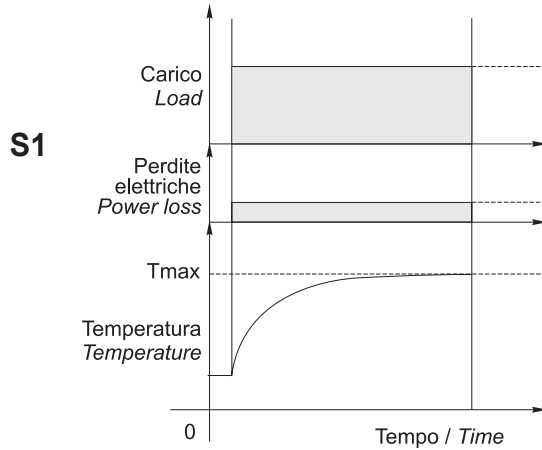

NOTA: Lo stesso motore può essere usato per cicli e servizi diversi, con l'unica limitazione che la temperatura interna non superi mai la Tmax stabilita dalla classe di isolamento termico del motore.

NOTE: The same motor can run under all duty services, limitation is due to internal temperature that must not override Tmax stated by motor thermal class.

Tabella pressacavi
Table of cable glands data
Serie SMT / SMT Series

TAGLIA SIZE	Pressacavo Cable gland
56 / 63	M16x1.5
71 / 80 / 90	M20x1.5

Serie SMM / SMM Series

TAGLIA SIZE	Pressacavo Cable gland
56 / 63	2 x M16x1.5
71	1x M20x1.5 + 1 x M16x1.5



Connessioni e collegamenti

Connection diagram

Riferimenti

References

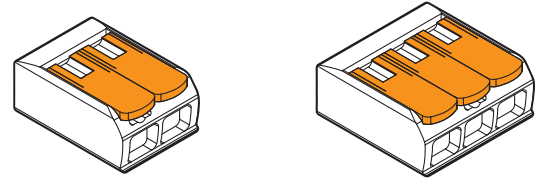
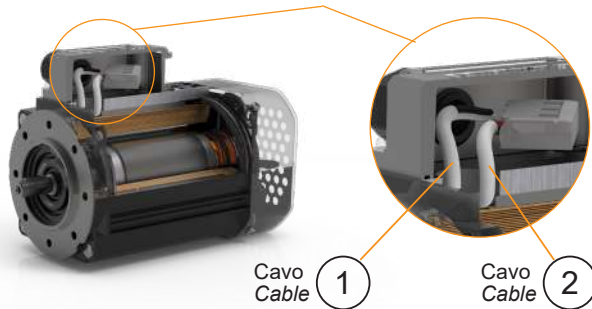

Morsetto di collegamento a leva a 2 e 3 poli
Splicing connector with lever 2- and 3-pin.

400/460 V - Trifase / three phase

Collegamento a stella / Star connection

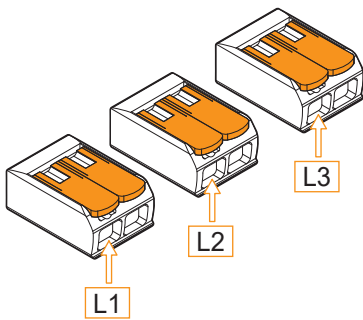

Morsetti a levetta liberi per alimentazione motore
Splicing connector with free-lever for the motor power source

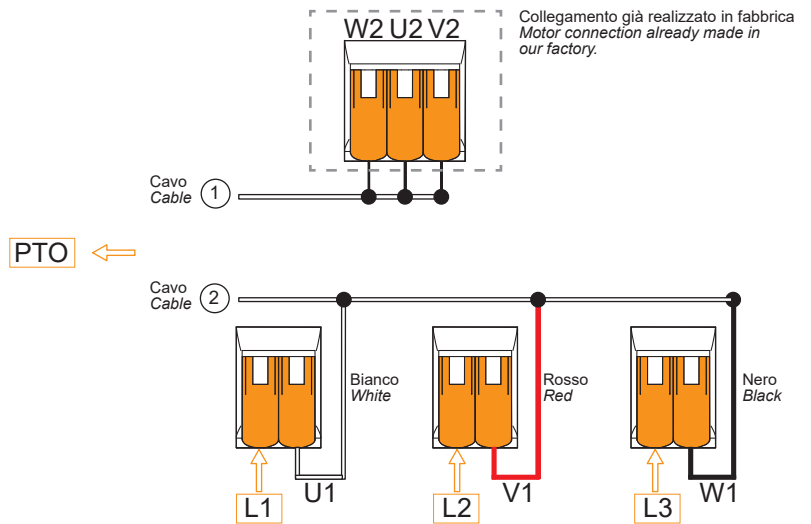

230 V - Trifase / three phase

Collegamento a triangolo / Delta connection

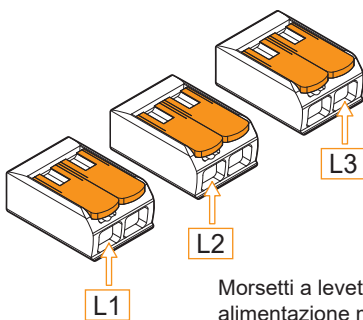

Splicing connector with free-lever for the motor power source

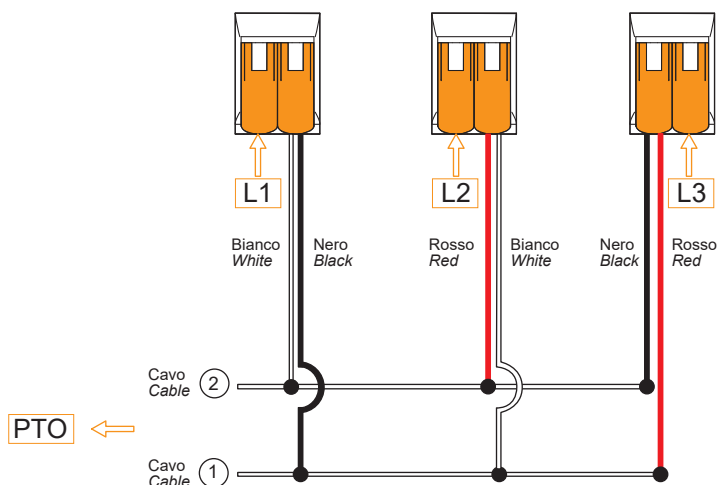

I motori della serie SM sono forniti in collegamento a stella, lo schema di collegamento a triangolo sopra riportato fornisce una chiara indicazione delle modifiche che il cliente può apportare in autonomia. Se necessario contattare il Servizio Tecnico Transtecno.

The SM series is supplied in star connection, the delta connection diagram shown above provides a clear indication of the modification that the customer can make independently. If needed, contact Transtecno Technical Service.

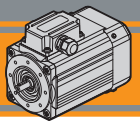

Connessioni e collegamenti

Connection diagram

115 V - Monofase / single phase

Monofase da SMM 56... a SMM 71... / Single phase from SMM 56... to SMM 71...

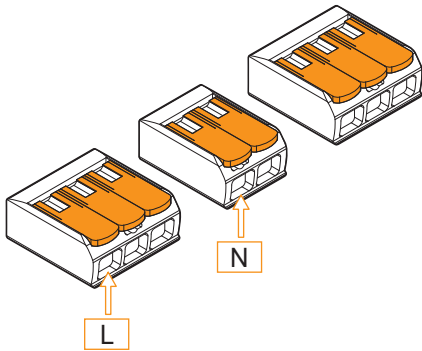

Morsetti a levetta liberi per alimentazione motore
Splicing connector with free-lever for the motor power source

Senso di rotazione orario
Clockwise direction of rotation

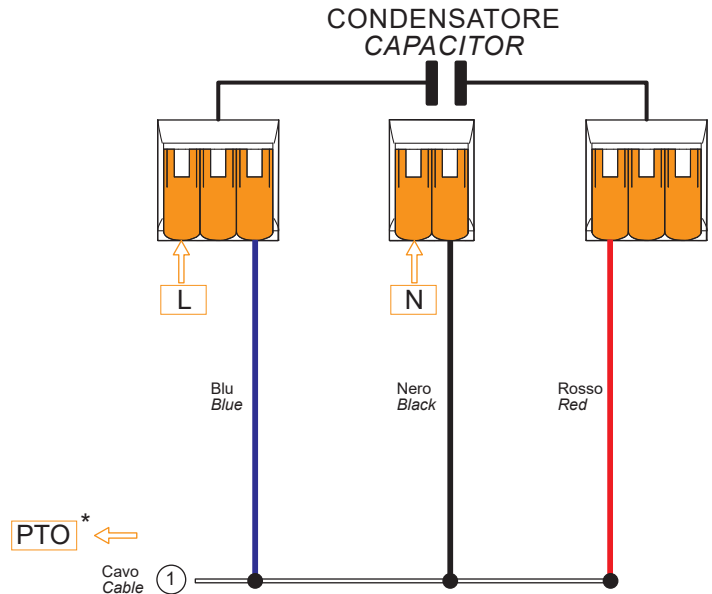
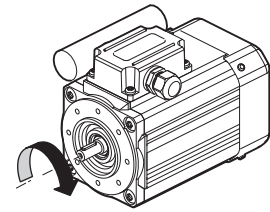

115 V - Monofase / single phase

Monofase da SMM 56... a SMM 71... / Single phase from SMM 56... to SMM 71...

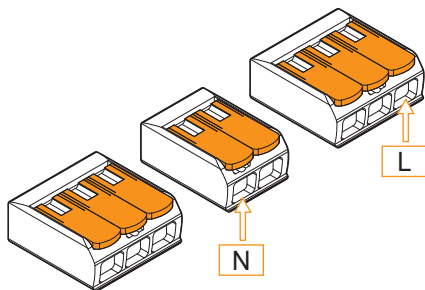

Morsetti a levetta liberi per alimentazione motore

Splicing connector with free-lever for the motor power source

Senso di rotazione antiorario
Counter-clockwise direction of rotation

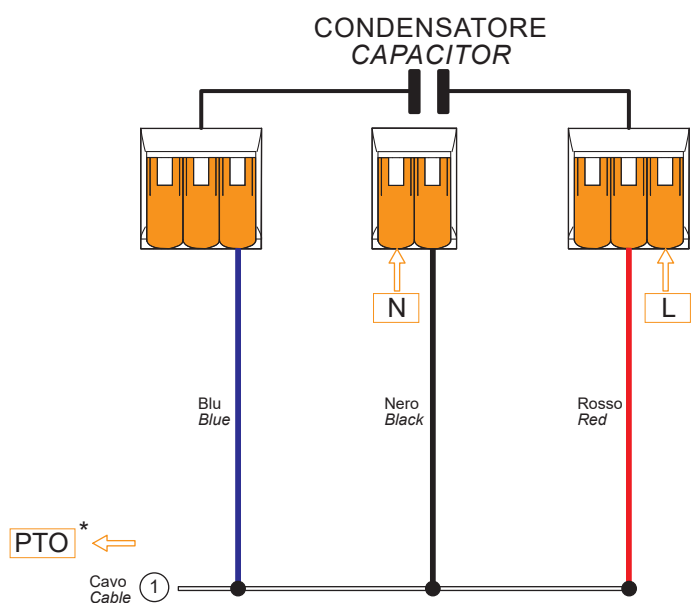
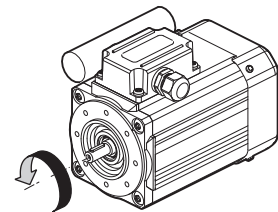

*: collegamento al circuito di comando del motore a cura del cliente. Per ragioni di sicurezza è sconsigliato il collegamento in serie. Se necessario contattare il Servizio Tecnico Transtecno.

*: motor supply connection by the customer. For safety reason Transtecno advises against PTO connected in series. If needed, contact Transtecno Technical Service.

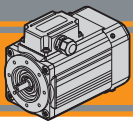

Targhetta

Nameplate

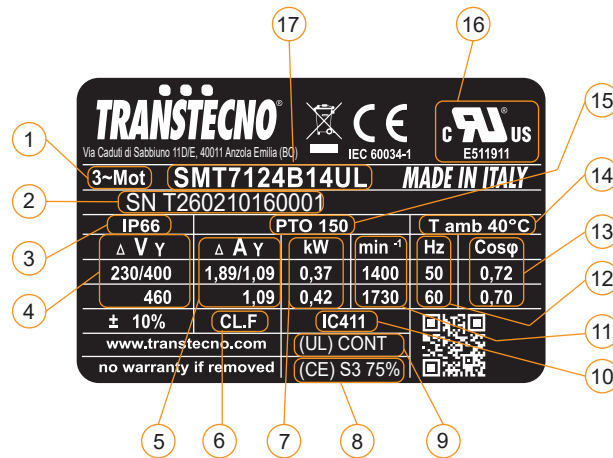

Pos.	Descrizione	Description
1	Tipo di alimentazione	Power supply
2	Numero di serie	Serial number
3	Grado di protezione IP motore	Motor IP protection rating
4	Tensione di alimentazione	Supply voltage
5	Corrente nominale	Rated current
6	Classe di isolamento	Insulation class
7	Potenza nominale	Rated power
8	Servizio per certificazione CE	CE compliance duty
9	Servizio per certificazione UL/CSA	UL/CSA compliance duty
10	Ventilazione	Fan cooling
11	Velocità nominale	Rated speed
12	Frequenza nominale	Rated frequency
13	Fattore di potenza	Power factor
14	Temperatura ambiente massima	Max allowed ambient temperature
15	Protezione termica PTO 150°C	PTO 150°C Thermal protection
16	Certificazione UL/CSA	UL/CSA compliance
17	Tipo di motore	Motor type

**TRANSTECNO SRL
HEADQUARTERS**

Company subject to the management
and coordination of INTERPUMP GROUP SPA
Via Caduti di Sabbiuno, 11/D-E
40011 Anzola dell'Emilia (BO)
ITALY
T+39 051 64 25 811
F +39 051 73 49 43
sales@transtecno.com
www.transtecno.com



TRANSTECNO®
the modular gearmotor

MEMBER OF INTERPUMP GROUP



**HANGZHOU TRANSTECNO POWER
TRANSMISSIONS CO LTD**
No.4 Xiuyan Road Fengdu Industry Zone
Pingyao Town Yuhang District
Hangzhou City, Zhejiang Province
311115 – CHINA
T +86 571 86 92 02 60
info-china@transtecno.cn
www.transtecno.cn



MA TRANSTECNO S.A.P.I. DE C.V.
Av. Mundial # 176, Parque Industrial
JM Apodaca, Nuevo León,
C.P. 66600 - MÉXICO
T +52 8113340920
info@transtecno.com.mx
www.transtecno.com.mx



**TRANSTECNO IBÉRICA
THE MODULAR GEARMOTOR, S.A.**
Carrer de la Ciència, 45
08840 Viladecans (Barcelona) - SPAIN
T +34 931 598 950
info@transtecno.es
www.transtecno.es



TRANSTECNO B.V.
Siliciumweg 32
3812 SX Amersfoort - NETHERLANDS
T +31(0) 33 45 19 505
info@transtecno.nl
www.transtecno.nl



TRANSTECNO AANDRIJFTECHNIEK B.V.
Siliciumweg 32
3812 SX Amersfoort - NETHERLANDS
T +31(0) 33 20 47 006
info@transtecnoaandrijftechniek.nl
www.transtecnoaandrijftechniek.nl



TRANSTECNO USA
8 Creek Parkway,
Boothwyn PA 19061-8136 - UNITED STATES
T + 1 (610) 4970154

TRANSTECNO USA – WEST COAST BRANCH
14561 Fryelands Blvd SE
Monroe, WA 98272 - UNITED STATES
T +1 360-863-1300
usaoffice@transtecno.com
www.transtecno.com



TRANSTECNO CANADA
51 B Caldari Road Unit 10
Vaughan, ON L4K 4G3 - CANADA
T +1 905 761 0762
canadaoffice@transtecno.com
www.transtecno.com



TRANSTECNO CHILE-PERU
Av. Los Libertadores 41
Parque Industrial - Los Libertadores 16.500
Santiago, Colina - CHILE
T +56 2 29633870

Carretera Panamericana Sur KM 29.5,
Interior I-3, Z.I. Lurin - PERU
T +51 1 3546259 / + 51 1 3434231
chileoffice@transtecno.com
www.transtecno.com



TRANSTECNO INDIA
#6A, Sipcot Industrial complex, Phase-1, Elasagiri Road
Hosur – 635126 Tamilnadu - INDIA
T +91 4344 274434
M +91 81443 88800

TRANSTECNO INDIA – NORTH BRANCH
Plot No: 3 A, Sector 2, IIE, Sidcul, Pantnagar
U.S. Nagar, Uttarakhand – 263153 - INDIA
indiaoffice@transtecno.com
www.transtecno.com



TRANSTECNO BRAZIL
Rua Gilberto de Zorzi, 525 Forqueta - CEP. 95115-730
CX Postal 3544 Caxias do Sul RS – BRAZIL

TRANSTECNO BRAZIL – SÃO PAULO BRANCH
R. Mafalda Barnabe Soliane, 314 – CEP. 13347-610
Indaiatuba, São Paulo - BRAZIL
T +55 19 3437 2520

TRANSTECNO BRAZIL – PORTO ALEGRE BRANCH
Rua Dr. Freire Alemão 155 / 402 - CEP. 90450-060
Auxiliadora Porto Alegre RS - BRAZIL
T +55 51 3251 5447
M +55 51 811 45 962
braziloffice@transtecno.com
www.transtecno.com.br



INTERPUMP ANTRIEBSTECHNIK - TRANSTECNO
Vertriebsbüro Stuttgart - GERMANY
T +49 (0)171 4781909
germanoffice@transtecno.com
www.transtecno.com



SALES OFFICE OCEANIA
Unit 5, 12 Nyholt Drive, Yatala 4207
Queensland - AUSTRALIA
T +61 07 3800 0103
M +61 04 38060997



UNIT 9, 94 Boundary Rd, Sunshine West 3020
Victoria - AUSTRALIA
T +61 9312 4722
oceaniaoffice@transtecno.com
www.transtecno.com.au



SALES OFFICE SOUTH KOREA
772-41, Bongdong-ro, Bongdong-eup, Wanju-goon
Chonbuk, 55313
SOUTH KOREA
T +82 70 8867 8897
M +82 10 5094 2107
koreaoffice@transtecno.com
www.transtecno.com

www.transtecno.com