

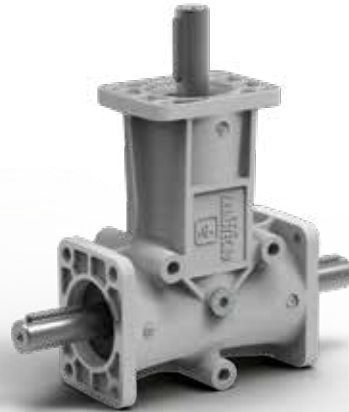







**TRANSTECNO**<sup>®</sup>  
the modular gearmotor

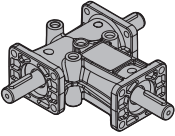

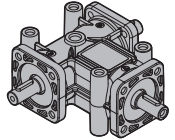

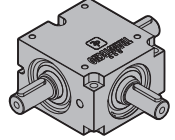
	Indice	Index	Pag. Page
	<b>A</b> Introduzione	Introduction	A1
 	<b>B</b> Rinvii angolari DZ	Right-angle bevel gearboxes DZ	B1
 	<b>C</b> Rinvii angolari ZP	Right-angle bevel gearboxes ZP	C1
 	<b>D</b> Rinvii angolari BB	Right-angle bevel gearboxes BB	D1
 	<b>E</b> Rinvii angolari QB	Right-angle bevel gearboxes QB	E1

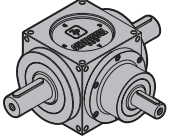
Questo catalogo annulla e sostituisce ogni precedente edizione o revisione.  
Ci riserviamo inoltre il diritto di apportare modifiche senza preavviso.  
La versione più aggiornata è disponibile sul sito  
[www.transtecno.com](http://www.transtecno.com)

*This catalogue supersedes any previous edition and revision.  
We reserve the right to implement modifications without notice.  
The most updated version is available on our website  
[www.transtecno.com](http://www.transtecno.com)*



<b>Indice</b>	<b>Index</b>	Pag. Page
Generalità	<i>General information</i>	<b>A2</b>
Velocità entrata	<i>Input speed</i>	<b>A2</b>
Rapporto di riduzione	<i>Gear ratio</i>	<b>A2</b>
Velocità in uscita	<i>Output speed</i>	<b>A2</b>
Coppia richiesta	<i>Requested torque</i>	<b>A2</b>
Coppia nominale	<i>Nominal torque</i>	<b>A3</b>
Coppia trasmessa	<i>Output torque</i>	<b>A3</b>
Rendimento	<i>Efficiency</i>	<b>A3</b>
Potenza in entrata	<i>Input power</i>	<b>A3</b>
Fattore di servizio	<i>Service factor</i>	<b>A4</b>
Carico radiale	<i>Radial load</i>	<b>A5</b>
Carico assiale	<i>Axial load</i>	<b>A5</b>
Scelta del rinvio angolare	<i>Selecting the right-angle bevel gearbox</i>	<b>A6</b>
Lubrificazione	<i>Lubrication</i>	<b>A7</b>
Posizioni di montaggio	<i>Mounting positions</i>	<b>A8</b>
Temperatura di lavoro	<i>Operating temperature</i>	<b>A9</b>
Installazione e verifiche	<i>Installation and inspection</i>	<b>A10</b>
Applicazioni critiche	<i>Critical applications</i>	<b>A10</b>

Questa sezione annulla e sostituisce ogni precedente edizione o revisione. Qualora questa sezione non Vi sia giunta in distribuzione controllata, l'aggiornamento dei dati ivi contenuto non è assicurato. **In tal caso la versione più aggiornata è disponibile sul nostro sito internet [www.transtecno.com](http://www.transtecno.com)**

*This section replaces any previous edition and revision. If you obtained this catalogue other than through controlled distribution channels, the most up to date content is not guaranteed. **In this case the latest version is available on our web site [www.transtecno.com](http://www.transtecno.com)***

## Generalità

## General information

Per avere una migliore comprensione degli argomenti e dei dati esposti in questo catalogo proponiamo la simbologia utilizzata corredandola delle informazioni di base per giungere ad una corretta selezione dei motoriduttori.

Information in this manual is provided with symbols in order to understand the subject matter and data. These symbols are intended to aid the user in selecting the right gearmotors.

## Velocità entrata

$n_1$  [min<sup>-1</sup>]

## Input speed

Rappresenta la velocità riferita al tipo di motorizzazione prescelta ed è applicata in entrata al rinvio angolare.

This is the input speed at the right-angle bevel gearbox related to the type of drive unit selected.

Per selezioni a velocità diverse da quelle riportate consultare il ns. Servizio Tecnico.

When different speeds are required, contact our Technical Service.

## Rapporto di riduzione

$i$

## Gear ratio

E' una grandezza adimensionale ed è in funzione del numero dei denti degli ingranaggi interni al rinvio angolare. Dai dati di catalogo si può ottenere con la relazione:

This value is strictly related to the size and number of teeth gears inside the right-angle bevel gearbox. From the data given in the catalogue, the value can be calculated using the following formula:

$$i = \frac{n_1}{n_2}$$

## Velocità in uscita

$n_2$  [min<sup>-1</sup>]

## Output speed

E' la velocità risultante sull' asse di uscita del rinvio angolare e viene ricavata dalla relazione precedente:

This is the right-angle bevel gearbox output speed calculated using the formula given above:

$$n_2 = \frac{n_1}{i}$$

## Coppia richiesta

$Mr_2$  [Nm]

## Requested torque

E' la coppia richiesta dall'applicazione ed è indispensabile per la selezione di una motorizzazione. Essa può essere comunicata dall'utente oppure calcolata in base ai dati di applicazione (se forniti).

This is the torque needed for the application and must be known when selecting a drive system. It can either be provided by the user or calculated according to the application data (if provided).

### Coppia nominale

$Mn_2$  [Nm]

Nominal torque

Rappresenta la coppia in uscita trasmissibile dal rinvio angolare in base alla velocità in entrata  $n_1$  e al rapporto di riduzione  $i$ . Essa è calcolata in base ad un servizio con carico continuo uniforme corrispondente ad un fattore di servizio uguale a 1. Questo valore non è riportato nel presente catalogo ma può essere ricavato approssimativamente con la seguente relazione fra  $M_2$  (coppia trasmessa) e  $sf$  (fattore di servizio):

*This is the output torque that can be transmitted by the right-angle bevel gearbox according to input speed  $n_1$  and gear ratio  $i$ . It is calculated based on service with a continuous steady load corresponding to a service factor equal to 1. This value is not given in the catalogue but can be calculated approximately with the following formula between  $M_2$  (output torque) and  $sf$  (service factor):*

$$Mn_2 = M_2 \cdot sf$$

### Coppia Trasmessa

$M_2$  [Nm]

Output torque

E' la coppia trasmessa in uscita al rinvio angolare. Dipende dalla potenza  $P_1$  del motore installato, dal numero di giri in uscita  $n_2$  e dal rendimento dinamico  $Rd$  e può essere calcolata con la relazione:

*This is the right-angle bevel gearbox's output torque. It is strictly related to power  $P_1$  of the motor installed, output rpm  $n_2$  and dynamic efficiency  $Rd$ . It can be calculated with the following formula:*

$$M_2 = \frac{9550 \cdot P_1 \cdot Rd}{n_2}$$

oppure:  
or:

$$M_2 = \frac{9550 \cdot P_2}{n_2}$$

dove:  
where:

$$P_2 = P_1 \cdot Rd$$

### Rendimento

$Rd; Rs$

Efficiency

I calcoli delle prestazioni sono stati effettuati in base al rendimento dinamico  $Rd$  dei rinvii angolari (valore ottimale che si raggiunge nel funzionamento a regime dopo rodaggio).

*Efficiency is calculated based on dynamic efficiency  $Rd$  of the right-angle bevel gearboxes (optimal value reached when running at normal speed after the break in period).*

Nei rinvii angolari il rendimento medio, trascurando le variazioni non significative dei vari rapporti, è del 97%.

*In right-angle bevel gearboxes, the average efficiency, disregarding non-significant variations in the various ratios, is 97%.*

### Potenza in entrata

$P_1$  [kW]

Input power

E' la potenza motore applicata in entrata al rinvio angolare e riferita alla velocità  $n_1$ . Può essere calcolata come segue:

*This is the power applied by the motor at the right-angle bevel gearbox input in reference to speed  $n_1$ . It can be calculated with the following formula:*

$$P_1 = \frac{M_2 \cdot n_2}{9550 \cdot Rd}$$

Fattore di servizio

sf

Service factor

E' una grandezza adimensionale che indica il sovradimensionamento da applicare ad una determinata motorizzazione per garantire la resistenza agli urti e la durata richiesta.

This value indicates how a certain drive system is to be over-sized in order to assure the requested service and stand up to shocks.

Per una corretta interpretazione dei valori del fattore di servizio sf, riportiamo nelle tabelle seguenti i valori indicativi attribuiti alle classi di carico A, B, C e alla durata di funzionamento giornaliero h/d e al numero di avviamenti/ora.

To correctly understand service factor values sf, approximate values for load classes A, B and C along with the number of hours of daily operation h/d and number of start-ups/hours need to be known.

Definendo la classe di carico a cui riferire l'applicazione, si ricercherà nella tabella il corrispondente valore di sf da utilizzare nella scelta della motorizzazione più idonea.

Once the load class required for the application has been determined, locate corresponding value sf to be used when selecting the most suitable drive system.

<b>A - Uniforme</b>	$fa \leq 0.3$
<b>B - Medio</b>	$fa \leq 3$
<b>C - Forte</b>	$fa \leq 10$

<b>A - Uniform</b>	$fa \leq 0.3$
<b>B - Moderate shocks</b>	$fa \leq 3$
<b>C - Heavy shocks</b>	$fa \leq 10$

$fa = \frac{Je}{Jm}$

- Je (kgm<sup>2</sup>) momento d'inerzia esterno ridotto all'albero motore.
- Jm (kgm<sup>2</sup>) momento d'inerzia motore.

Se  $fa > 10$  interpellare il sn. Servizio Tecnico.

$fa = \frac{Je}{Jm}$

- Je (kgm<sup>2</sup>) moment of reduced external inertia at the drive-shaft
- Jm (kgm<sup>2</sup>) moment of inertia of motor.

If  $fa > 10$  call our Technical Service.

**A** Classe di carico / Load class  
**Carico uniforme / Uniform load**

		sf								
		n. avviamenti/ora / n. start-up/hour								
h/d		2	4	8	16	32	63	125	250	500
4		0.8	0.8	0.9	0.9	1.0	1.1	1.1	1.2	1.2
8		1.0	1.0	1.1	1.1	1.3	1.3	1.3	1.3	1.3
16		1.3	1.3	1.3	1.3	1.5	1.5	1.5	1.5	1.5
24		1.5	1.5	1.5	1.5	1.8	1.8	1.8	1.8	1.8

**B** Classe di carico / Load class  
**Carico con urti moderati / Moderate shock load**

		sf								
		n. avviamenti/ora / n. start-up/hour								
h/d		2	4	8	16	32	63	125	250	500
4		1.0	1.0	1.0	1.0	1.3	1.3	1.3	1.3	1.3
8		1.3	1.3	1.3	1.3	1.5	1.5	1.5	1.5	1.5
16		1.5	1.5	1.5	1.5	1.8	1.8	1.8	1.8	1.8
24		1.8	1.8	1.8	1.8	2.2	2.2	2.2	2.2	2.2

**C** Classe di carico / Load class  
**Carico con urti forti / Heavy shock load**

		sf								
		n. avviamenti/ora / n. start-up/hour								
h/d		2	4	8	16	32	63	125	250	500
4		1.3	1.3	1.3	1.3	1.5	1.5	1.5	1.5	1.5
8		1.5	1.5	1.5	1.5	1.8	1.8	1.8	1.8	1.8
16		1.8	1.8	1.8	1.8	2.2	2.2	2.2	2.2	2.2
24		2.2	2.2	2.2	2.2	2.5	2.5	2.5	2.5	2.5

Esempio applicazione:

Nastro trasportatore attribuibile alla classe di carico B (**carico con urti moderati**) e previsto per una durata di funzionamento giornaliero (h/d) di 8 ore e con 8 avviamenti/ora. Dalla tabella rileviamo **sf = 1.3**

Application example:

Conveyor belt assigned to load class B (**moderate shock load**), to be run 8 hours a day (h/d) with 8 start-ups/hour. The following value is obtained from the table **sf = 1.3**



### Carico radiale

**R; R<sub>1</sub>; R<sub>2</sub> [N]**

### Radial load

L'applicazione sugli alberi di entrata o di uscita del rinvio angolare di pignoni, pulegge, ecc. determina delle forze radiali che debbono necessariamente essere considerate per evitare sollecitazioni eccessive con il rischio di danneggiamenti del rinvio stesso. Il calcolo del carico radiale esterno R agente sull'albero del rinvio angolare può essere determinato come segue:

$$R = \frac{2000 \cdot M_2 \cdot kr}{d} \leq R_1$$

$$R = \frac{2000 \cdot M_2 \cdot kr}{d} \leq R_2$$

dove:

**d [mm]** diametro primitivo del pignone o della puleggia  
**kr** coefficiente riferito al tipo di trasmissione:  
**kr = 1.4** ruota per catena  
**kr = 1.1** ingranaggio  
**kr = 1.5 - 2.5** puleggia per cinghia a V

where:

**d [mm]** diameter of the pinion or pulley  
**kr** coefficient in relation to type of transmission:  
**kr = 1.4** sprocket wheel  
**kr = 1.1** gear  
**kr = 1.5 - 2.5** pulley for V belts

E' opportuno evidenziare che i valori di R<sub>1</sub> e R<sub>2</sub> sono riferiti a carichi agenti sulla mezzeria dell'albero (considerando l'albero sporgente) per cui il confronto dovrà essere effettuato nelle medesime condizioni.

*Pinions, pulleys, etc applied on the output shaft of the right-angle bevel gearboxes create radial forces that must be taken into consideration to avoid excessive stress risking damage to the right-angle bevel gearbox itself. External radial load R that acts on the right-angle bevel gearbox shaft can be calculated as follows:*

*Keep in mind that values R<sub>1</sub> and R<sub>2</sub> refer to loads that act on the center-line of the shaft (considering the shaft protrudes). As a result, the value should be compared under the same conditions.*

### Carico assiale

**A; A<sub>1</sub>; A<sub>2</sub> [N]**

### Axial load

A volte, unitamente al carico radiale, può essere presente anche una forza A che agisce assialmente sull'albero entrata o uscita;

*At times, along with the radial load, force A may be present that acts axially on the input or output shaft.*

$$A \leq A_1$$

$$A \leq A_2$$

Nel caso in cui il valore del carico assiale A agente sull'albero risultasse superiore ad A<sub>1</sub> e A<sub>2</sub> contattate il ns. Servizio Tecnico.

*If axial load A that acts on the shaft is greater than A<sub>1</sub> and A<sub>2</sub>, contact our Technical Service.*

### Scelta del rinvio angolare

### Selecting the right-angle bevel

Per la scelta di un rinvio angolare è necessario seguire la seguente procedura.

*To select the required right-angle bevel, perform the procedure below:*

1. Per l'applicazione desiderata ricavare il fattore di servizio sf dalle tabelle a pag. A4 in base alla classe di carico, alle ore di funzionamento giornaliero e al numero di avviamenti orari.
2. Se si conosce la potenza motore P [kW] richiesta, passare al punto 3); se è nota la coppia in uscita Mr<sub>2</sub> richiesta è necessario calcolare la potenza motore P con le formule:

1. Determine the service factor sf for the desired application by referring to the charts given on page A4. This is to be done by considering the class of load, the operational hours/day and the number of start-ups/ hour.
2. If the required motor power output P is known, go to item 3); if the required output torque Mr<sub>2</sub> is known, determine motor output P by using the following formulas:

$$P = \frac{Mr_2 \cdot n_2}{9550 \cdot Rd}$$

dove Rd è il rendimento dinamico (0.96) e n<sub>2</sub> il numero di giri richiesti in uscita al rinvio angolare.

*where Rd stands for the dynamic efficiency (0.96) and n<sub>2</sub> indicates the required output rpm of the right-angle bevel.*

3. Nota la potenza motore P [kW], calcolare la potenza effettiva  $P_e$  con la seguente formula:

$$P_e = P \times sf$$

3. Given the motor power P [kW], calculate the effective power  $P_e$  using the following formula:

4. Considerando la velocità di uscita del rinvio  $n_2$ , scegliere nella tabella dei dati tecnici un rinvio che abbia una potenza nominale  $P_{n1}$  uguale o superiore alla potenza effettiva  $P_e$ .

4. Considering the gearbox output speed  $n_2$ , choose a gearbox with a nominal power  $P_{n1}$  equal to or higher than the effective power  $P_e$  from the technical data table.

5. Controllare che i carichi radiali R e assiali A, in entrata ed uscita, applicati al centro dell'albero sporgente o al centro della cavità, non superino i valori riportati nella tabella dei carichi radiali ed assiali.

5. Check that the input and output radial loads R and axial loads A applied to the centre of the protruding shaft or the centre of the cavity do not exceed the values given in the table of radial and axial loads.

6. Verificare che la temperatura di esercizio non superi i valori da  $-20^\circ\text{C}$  a  $+80^\circ\text{C}$

6. Check that the operating temperature does not exceed  $-20^\circ\text{C}$  to  $+80^\circ\text{C}$

7.

### Per DZ e ZP

Nel caso di utilizzo del rinvio in moltiplica si raccomanda di non superare in ingresso il numero di giri di  $750 \text{ min}^{-1}$  nel rapporto 2:1 e  $500 \text{ min}^{-1}$  nel rapporto 3:1

7.

### For DZ and ZP

When using the gearbox in the gear ratio, it is recommended not to exceed an input speed of  $750 \text{ min}^{-1}$  in the 2:1 ratio and  $500 \text{ min}^{-1}$  in the 3:1 ratio

### Per QB

Nel caso di utilizzo del rinvio in moltiplica si raccomanda di non superare in ingresso il numero di giri di  $2000 \text{ min}^{-1}$  nel rapporto 1.5:1,  $1500 \text{ min}^{-1}$  nel rapporto 2:1,  $1000 \text{ min}^{-1}$  nel rapporto 3:1 e  $750 \text{ min}^{-1}$  nel rapporto 4:1

### For QB

When using the gearbox in the gear ratio, it is recommended not to exceed an input speed of  $2000 \text{ min}^{-1}$  in the ratio 1.5:1,  $1500 \text{ min}^{-1}$  in the ratio 2:1,  $1000 \text{ min}^{-1}$  in the ratio 3:1 and  $750 \text{ min}^{-1}$  in the ratio 4:1

8. In presenza di ambienti particolarmente polverosi e conseguentemente abrasivi, evitare l'esposizione diretta del paraolio che ne ridurrebbe di fatto la durata

8. In particularly dusty and consequently abrasive environments, avoid direct exposure of the oil seal, which would effectively reduce its service life

	i	$n_1$	$n_2$	$M_{n2}$	$P_{n1}$	$n_1$	$n_2$	$M_{n2}$	$P_{n1}$	$n_1$	$n_2$	$M_{n2}$	$P_{n1}$	$n_1$	$n_2$	$M_{n2}$	$P_{n1}$	$n_1$	$n_2$	$M_{n2}$	$P_{n1}$
		[ $\text{min}^{-1}$ ]	[ $\text{min}^{-1}$ ]	[Nm]	[kW]	[ $\text{min}^{-1}$ ]	[ $\text{min}^{-1}$ ]	[Nm]	[kW]	[ $\text{min}^{-1}$ ]	[ $\text{min}^{-1}$ ]	[Nm]	[kW]	[ $\text{min}^{-1}$ ]	[ $\text{min}^{-1}$ ]	[Nm]	[kW]	[ $\text{min}^{-1}$ ]	[ $\text{min}^{-1}$ ]	[Nm]	[kW]
DZ 1	1	50	50	4.7	0.02	100	100	3.9	0.04	250	250	3.0	0.08	500	500	2.6	0.13	750	750	2.4	0.18
	2		25	3.6	0.01		50	3.5	0.02		125	3.1	0.04		250	2.7	0.07		375	2.5	0.09
	1	1000	1000	2.1	0.21	1500	1500	1.9	0.29	2000	2000	1.8	0.36	2500	2500	1.75	0.44	3000	3000	1.7	0.51
	2		500	2.2	0.11		750	1.9	0.14		1000	1.8	0.18		1250	1.75	0.22		1500	1.7	0.26
DZ 2	1	50	50	16.5	0.08	100	100	14	0.14	250	250	10.5	0.26	500	500	9.0	0.45	750	750	8.5	0.64
	2		25	15	0.04		50	15	0.08		125	11	0.14		250	9.5	0.24		375	9.1	0.34
	1	1000	1000	7.5	0.75	1500	1500	6.9	1.04	2000	2000	6.6	1.33	2500	2500	6.2	1.56	3000	3000	5.9	1.78
	2		500	8.0	0.40		750	6.9	0.52		1000	6.5	0.65		1250	6.4	0.80		1500	6.3	0.95
DZ 3	1	50	50	53	0.27	100	100	45	0.45	250	250	34	0.85	500	500	30	1.51	750	750	29	2.15
	2		25	39	0.10		50	37	0.19		125	33	0.41		250	28	0.70		375	26.5	1.00
	1	1000	1000	25	2.51	1500	1500	22	3.32	2000	2000	21	4.22	2500	2500	20	5.03	3000	3000	19	5.73
	2		500	23.2	1.17		750	20.5	1.55		1000	20	2.01		1250	19.5	2.45		1500	19	2.86

Esempio / Example:

### Applicazione / Application:

Nastro trasportatore / Conveyor belt

P : 2.2 kW

sf : 1.3 (Carico con urti moderati, funzionamento 8 h/gg, 8 avv/h / Moderate shock load, 8 h/day, 8 start/h operation)

$n_2$  :  $1500 \text{ min}^{-1}$

$P_e = P \times sf = 2.2 \times 1.3 = 2.86 \text{ kW}$

Motorizzazione scelta / Power unit selected:

DZ3 (Potenza massima applicabile  $P_{n1} = 3.32 \text{ kW}$  a  $1500 \text{ min}^{-1}$  / Maximum applicable power  $P_{n1} = 3.32 \text{ kW}$  at  $1500 \text{ min}^{-1}$ )

**Lubrificazione**

**Lubrication**

I rinvii angolari serie DZ1 , ZP1, BB grandezza 90 e QB grandezza 54 sono forniti completi di grasso minerale 00EP permanente

*Series DZ1 , ZP1, BB size 90 and QB size 54 right-angle bevel gearboxes are supplied complete with permanent 00EP mineral grease*

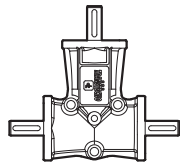

**DZ1**

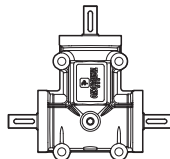

**ZP1**



**BB90**

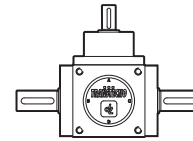

**QB54**

TAMOIL	SHELL	CASTROL
Tamlith Grease 00EP	Alvania Grease EP00	Tribol 3020/1000-00

I rinvii angolari serie BB grandezza 50 sono forniti completi di grasso minerale 2EP permanente

*Series BB size 50 right-angle bevel gearboxes are supplied complete with permanent 2EP mineral grease*



**BB50**

TAMOIL	SHELL	CASTROL
Tamlith Grease 2EP	Alvania Grease EP2	Tribol 3020/1000-2

I rinvii angolari serie DZ2, DZ3, DZ4, DZ5, ZP2, ZP3, ZP4, QB (tranne la grandezza 54) sono forniti completi di lubrificante sintetico ISO 150.

*Right-angle bevel gearboxes series DZ2, DZ3, DZ4, DZ5, ZP2, ZP3, ZP4, QB (except size 54) are supplied complete with synthetic lubricant ISO 150.*

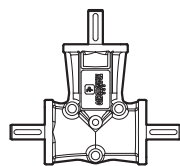

**DZ..**

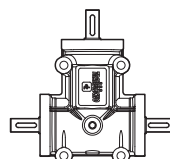

**ZP..**

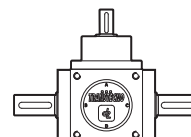

**QB..**

SHELL	KLUBER	CASTROL	MOBIL	TAMOIL
Omala S4 WE 150	Klübersynth GH 6-150	Alphasyn PG 150	Glygoyle 150	Carter EP 150

DZ

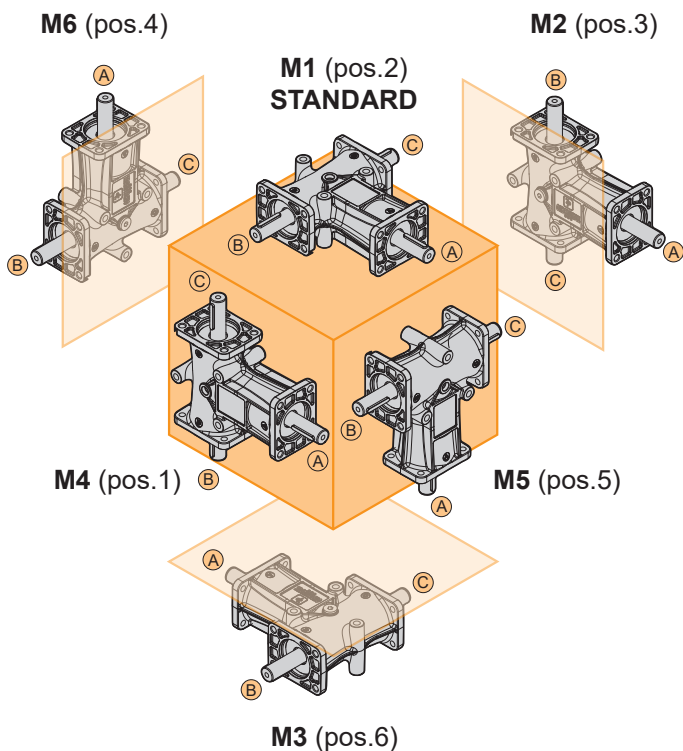

ZP

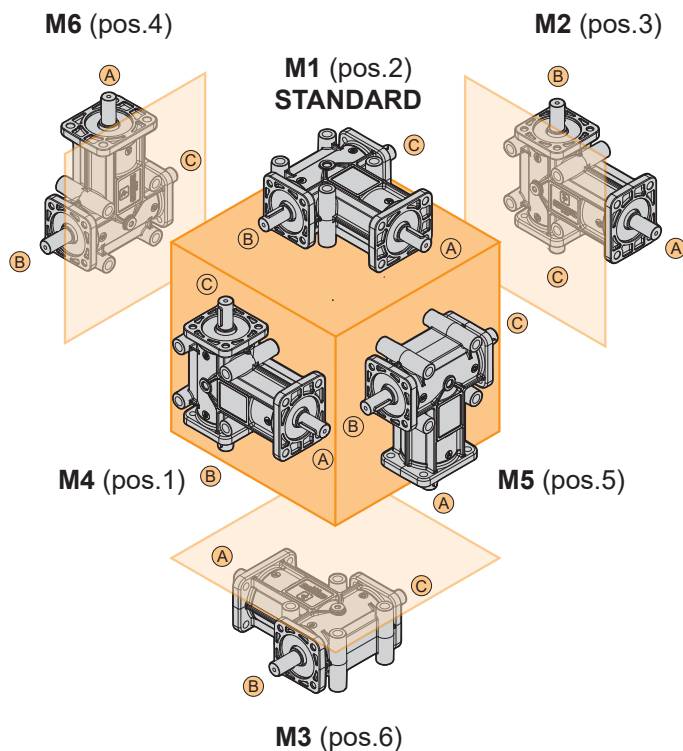

BB

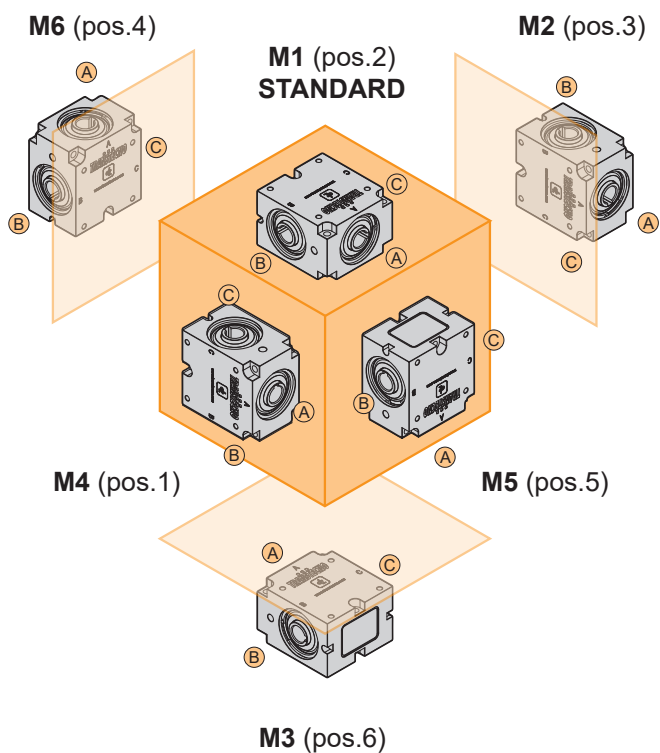

QB

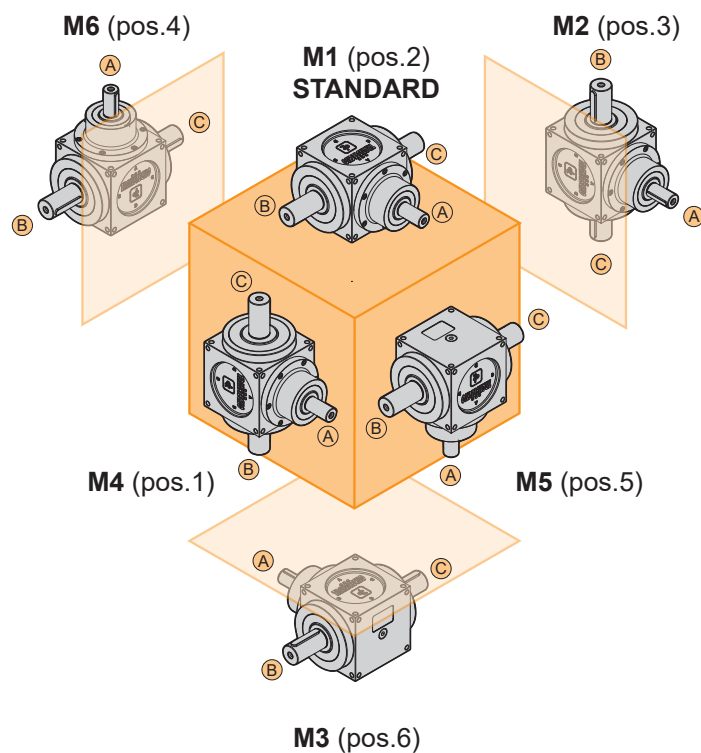

**Temperatura di lavoro**

**Operating temperature**

La temperatura ambientale influisce sulle specifiche dei rinvii angolari.

*The environmental temperature affects specifications of right-angle bevel gearboxes.*

**Campo di temperatura standard / Standard temperature range**

<b>DZ</b>	-10°C / +50°C
<b>ZP</b>	-10°C / +50°C
<b>BB</b>	-10°C / +50°C
<b>QB</b>	-10°C / +50°C

**Campi di temperatura speciali / Special temperature range**

	<-10°C	>+50°C
<b>DZ</b>	usare paraoli in silicone (VMQ) <i>use silicon (VMQ)</i> oil seals	usare paraoli in Viton (FPM) <i>use Viton (FPM)</i> oil seals
<b>ZP</b>		
<b>BB90</b>	usare lubrificante per basse temperature <i>use low temperature lubricant</i>	usare lubrificante per alte temperature <i>use high temperature lubricant</i>
<b>QB</b>		

Per temperature <0°C riferirsi alle seguenti note:

- verificare che il motore sia idoneo al funzionamento a bassa temperatura;
- assicurarsi che il motore possa fornire maggior coppia di avviamento a causa dell'aumento di viscosità del lubrificante;
- procedere con alcuni minuti di funzionamento a vuoto per garantire l'ottimale lubrificazione;

*For temperature <0°C refer to the following notes:*

- check if the motor is suitable for low temperature;*
- due to the high viscosity of the lubricant, check if the motor can supply high starting torque;*
- let the group run for a few minutes without load to guarantee good lubrication;*

## Installazione e verifiche

In fase di installazione del rinvio angolare è opportuno verificare che:

- i dati riportati in targhetta corrispondano al prodotto che è stato ordinato;
- le superfici di accoppiamento e gli alberi siano accuratamente puliti e privi di ammaccature;
- le superfici su cui verrà installato il rinvio angolare siano perfettamente piane e sufficientemente rigide;
- l'albero macchina e quello del rinvio angolare siano correttamente allineati;
- siano stati installati sistemi di limitazione della coppia se si prevedono urti o blocchi della macchina durante il funzionamento;
- siano state predisposte le necessarie protezioni antinfortunistiche agli organi rotanti;
- siano state create delle opportune coperture a protezione dagli agenti atmosferici se l'installazione è effettuata all'aperto ed è soggetta alle intemperie;
- l'ambiente di lavoro non sia corrosivo (a meno che tale specifica non sia stata dichiarata in fase di ordine al fine di predisporre il rinvio angolare per questo utilizzo);
- gli eventuali pignoni o pulegge montati sull'albero uscita o entrata del rinvio angolare, siano calettati correttamente in modo tale da non generare carichi radiali e/o assiali superiori a quelli ammissibili;
- su tutti gli accoppiamenti sia stato applicato un adeguato protettivo antiossidante per prevenire eventuali ossidazioni da contatto;
- tutte le viti di fissaggio siano state serrate correttamente.

## Applicazioni critiche

In tutti questi casi consultare il Servizio Tecnico

- utilizzo come moltiplicatore;
- utilizzo in ambiente con pressione diversa da quella atmosferica;
- utilizzo in ambiente con temperature  $<-10^{\circ}\text{C}$  o  $>+50^{\circ}\text{C}$

## Installation and inspection

*While installing the right-angle bevel gearbox, always make sure that:*

- *the specifications stamped on the rating plate match those indicated for the unit actually ordered;*
- *the mating surfaces and the shafts are thoroughly clean and free of dents;*
- *the surfaces where the right-angle bevel gearbox are to be mounted on are flat and strong enough;*
- *the machine drive shaft and the right-angle bevel gearbox shaft are perfectly aligned;*
- *the required torque limiters have been installed if the machine is likely to produce shocks or blockages during operation;*
- *the rotary parts have been provided with the required safety guards;*
- *adequate weatherproof covering has been provided if the machine is to be installed outdoor;*
- *the working environment is not exposed to corrosive agents (unless this has been indicated while placing the order so that the gearbox can be adequately set up);*
- *the pinions or pulleys on the gearbox input/output shafts are properly fitted in order not to produce radial and/or axial loads that exceed the maximum allowable limits;*
- *all the couplings have been treated with adequate rust preventative in order to avoid oxidation provoked by contact;*
- *all the mounting screws have been securely tightened.*

## Critical applications

*In these cases please contact the Technical Service*

- *used to increase speed ;*
- *use in environment pressure other than atmospheric pressure;*
- *use in places with temperature  $<-10^{\circ}\text{C}$  or  $>+50^{\circ}\text{C}$*



Rinvii angolari  
**Right-angle bevel gearboxes**

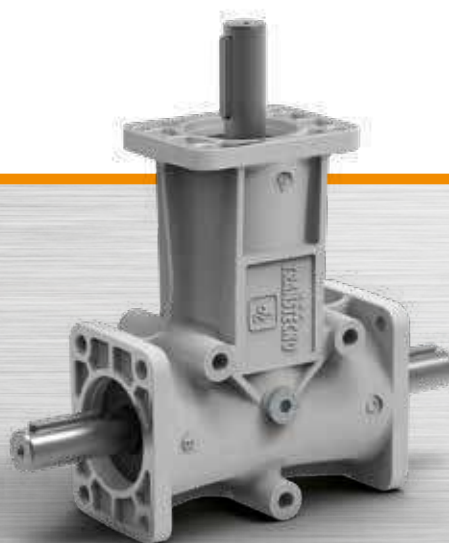





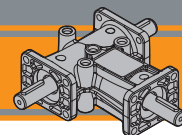

<b>Indice</b>	<b>Index</b>	Pag. Page
Caratteristiche tecniche	<i>Technical features</i>	<b>B2</b>
Designazione	<i>Classification</i>	<b>B3</b>
Versione	<i>Version</i>	<b>B3</b>
Sensi di rotazione	<i>Direction of rotation</i>	<b>B4</b>
Simbologia	<i>Symbols</i>	<b>B4</b>
Lubrificazione	<i>Lubrication</i>	<b>B4</b>
Carichi radiali e assiali	<i>Radial and axial loads</i>	<b>B5</b>
Dati tecnici	<i>Technical data</i>	<b>B9</b>
Dimensioni	<i>Dimensions</i>	<b>B10</b>

Questa sezione annulla e sostituisce ogni precedente edizione o revisione. Qualora questa sezione non Vi sia giunta in distribuzione controllata, l'aggiornamento dei dati ivi contenuto non è assicurato. **In tal caso la versione più aggiornata è disponibile sul nostro sito internet [www.transtecno.com](http://www.transtecno.com)**

*This section replaces any previous edition and revision. If you obtained this catalogue other than through controlled distribution channels, the most up to date content is not guaranteed. In this case the latest version is available on our web site [www.transtecno.com](http://www.transtecno.com)*

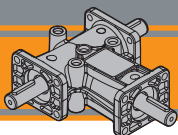

# DZ Rinvii angolari Right-angle bevel gearboxes

## Caratteristiche tecniche

I rinvii angolari serie DZ sono stati progettati per applicazioni industriali dove occorre trasmettere un moto rotatorio tra alberi disposti perpendicolarmente tra loro.

Sono disponibili:

- 5 grandezze: DZ1, DZ2, DZ3, DZ4 e DZ5
- 2 rapporti: 1/1 e 1/2;
- 2 o 1 prese moto uscita;
- 1 flangia ingresso e 2 flange uscita. Solo per le grandezze 1 e 2 è disponibile la versione con 1 sola flangia uscita

Caratteristiche comuni a tutta la serie sono:

- Carter monoblocco in lega di alluminio predisposta per il fissaggio in 3 punti o, in alternativa, alle 2 o 3 flange in corrispondenza delle prese moto
- Coppia Conica Spiroidale GLEASON in acciaio al Nichel Cromo con trattamento di Cementazione - Tempra
- Alberi maschio in acciaio al carbonio protetti superficialmente contro la corrosione con trattamento di fosfatazione. Le sedi linguetta (non presenti sulla taglia DZ1) possono assumere qualsiasi posizione angolare.
- Sulla taglia DZ3 è previsto un albero di uscita cavo con sede linguetta
- Cuscinetti radiali a sfere (DZ3 con albero cavo con cuscinetti conici in uscita)
- Anelli di Tenuta tipo A in NBR o Tappi in NBR ove l'albero non è sporgente
- Lubrificazione con olio sintetico ISO 150, ad esclusione delle grandezze 1 fornita con grasso minerale 00 EP permanente

## Technical features

DZ-series right-angle bevel gearboxes are designed for industrial applications where rotary motion must be transmitted between perpendicularly arranged shafts.

Those available:

- 5 sizes: DZ1, DZ2, DZ3, DZ4 and DZ5
- 2 ratios: 1/1 and 1/2;
- 2 or 1 output power take-off;
- 1 input flange and 2 output flanges. Only for sizes 1 and 2 the version with only 1 output flange is available

Common features throughout the series are:

- One-piece aluminium alloy casing prepared for 3-point fixing or, alternatively, 2 or 3 flanges at the power take-off
- GLEASON spiral bevel gear in Nickel Chrome steel with Case hardening treatment
- Solid shafts made of carbon steel, surface protected against corrosion with phosphating treatment. The keyways (not present on size DZ1) can assume any angular position.
- On size DZ3 there is a hollow output shaft with keyways
- Radial ball bearings (DZ3 with hollow shaft with conical output bearings)
- NBR type A sealing rings or NBR plugs where the shaft does not protrude
- Lubrication with synthetic oil ISO 150, except size 1 supplied with permanent 00 EP mineral grease

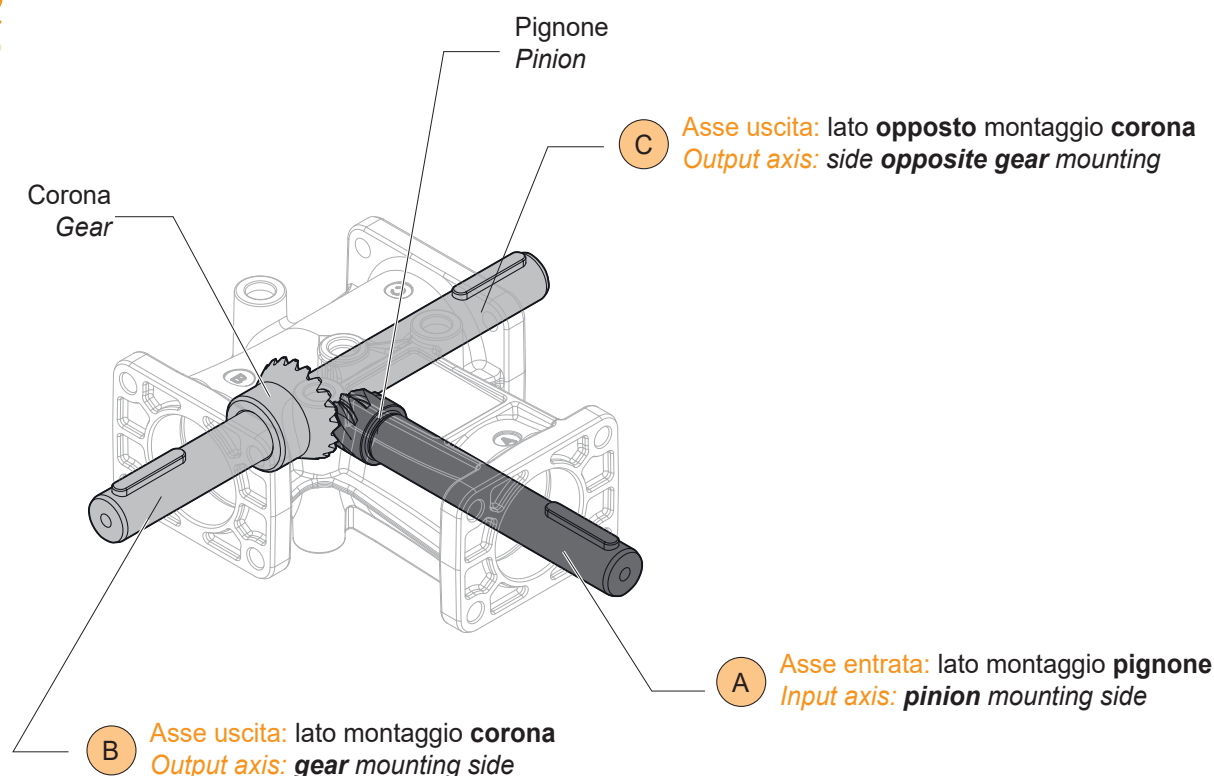

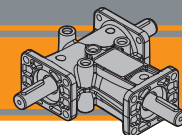

### Designazione

### Classification

RINVIO ANGOLARE / RIGHT-ANGLE BEVEL GEARBOX							
DZ	1	0	S	2F	A	B	-
Tipo Type	Grandezza Size	Rapporto Ratio	Tipo di montaggio Mounting type	Flangia Flange	Albero in A Shaft in A	Albero in B Shaft in B	Albero in C Shaft in C
<b>DZ</b>	<b>1</b> <b>2</b> <b>3</b> <b>4</b> <b>5</b>	<b>0 - 1</b> $i = 1/1$  <b>2 - 3</b> $i = 1/2$  <b>11</b> $i = 1/1$ Albero cavo Hollow shaft	<b>S</b>  <b>FS</b>  ...	<b>2F</b> (n°2)  <b>3F</b> (n°3)	<b>A</b>	<b>B</b>  -	<b>C</b>  -

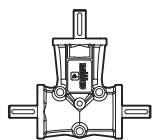

DZ

### Versione

### Version

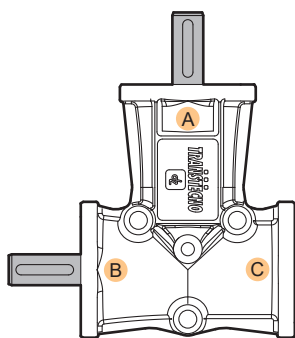

S..AB

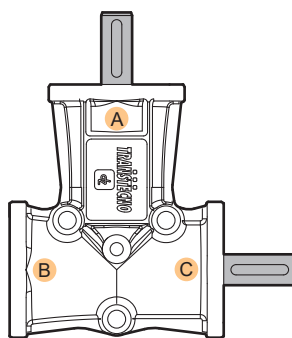

FS..AC

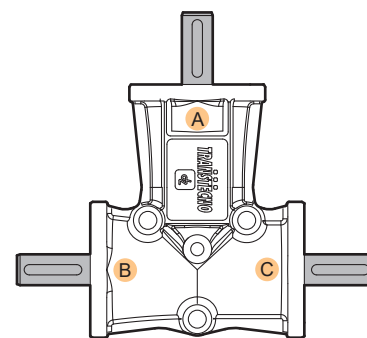

...ABC

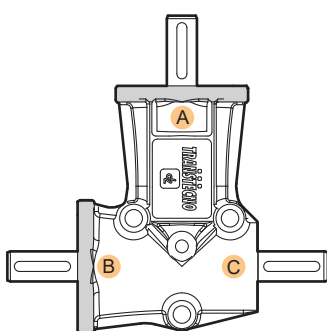

2F

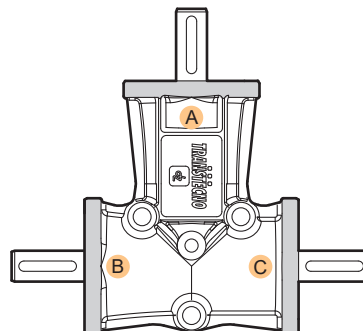

3F

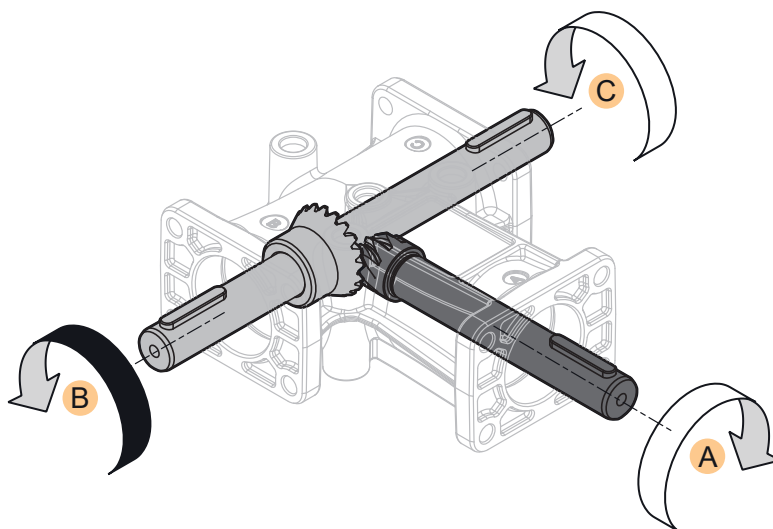
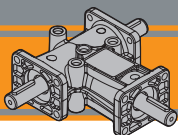

## Simbologia

## Symbols

$n_1$	[ $\text{min}^{-1}$ ]	Velocità in ingresso / <i>Input speed</i>
$n_2$	[ $\text{min}^{-1}$ ]	Velocità in uscita / <i>Output speed</i>
$i$		Rapporto di riduzione / <i>Ratio</i>
$P_1$	[kW]	Potenza in entrata / <i>Input power</i>
$M_2$	[Nm]	Coppia nominale in uscita in funzione di $P_1$ / <i>Output torque referred to <math>P_1</math></i>
$P_{n1}$	[kW]	Potenza nominale in entrata / <i>Nominal input power</i>
$M_{n2}$	[Nm]	Coppia nominale in uscita in funzione di $P_{n1}$ / <i>Nominal output torque referred to <math>P_{n1}</math></i>
$sf$		Fattore di servizio / <i>Service factor</i>
$R_1$	[N]	Carico radiale ammissibile in entrata / <i>Permitted input radial load</i>
$A_1$	[N]	Carico assiale ammissibile in entrata / <i>Permitted input axial load</i>
$R_2$	[N]	Carico radiale ammissibile in uscita / <i>Permitted output radial load</i>
$A_2$	[N]	Carico assiale ammissibile in uscita / <i>Permitted output axial load</i>
 [kg]		Peso del solo riduttore / <i>Weight of the gearbox only</i>

## Lubrificazione

## Lubrication

I rinvii angolari serie DZ, sono forniti completi di lubrificante sintetico ISO 150, ad esclusione delle grandezze 1 forniti con grasso minerale 00 EP.

*DZ-series right-angle bevel gearboxes are supplied complete with synthetic lubricant ISO 150, except size 1 supplied with 00 EP mineral grease.*

Possono essere installati in qualunque posizione di montaggio e non necessitano di manutenzione.

*They can be installed in any mounting position and are maintenance-free.*

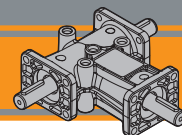

### Carichi radiali e assiali

### Entrata / Input

### Radial and axial loads

Per carichi radiali o assiali superiori a quelli di tabella si prega di contattare il servizio tecnico

For radial or axial loads higher than those in the table, please contact technical service

	n1 [min <sup>-1</sup> ]	i	n2 [min <sup>-1</sup> ]	R <sub>1</sub> [N]	A <sub>1</sub> [N]		n1 [min <sup>-1</sup> ]	i	n2 [min <sup>-1</sup> ]	R <sub>1</sub> [N]	A <sub>1</sub> [N]
DZ 1	50	1	50	140	100		100	1	100	140	100
		2	25					50			
	250	1	250	120	100		500	1	500	82	100
		2	125	140				250	140		
	750	1	750	65	100		1000	1	1000	39	75
		2	375	140				500	140		
	1500	1	1500	20	38		2000	1	2000	10	25
		2	750	130				1000	120	100	
	2500	1	2500	5	12		3000	1	3000	*	*
		2	1250	110				1500	100	100	
DZ 2	50	1	50	330	220		100	1	100	330	220
		2	25					50			
	250	1	250	200	220		500	1	500	135	220
		2	125	315				250	270		
	750	1	750	120	220		1000	1	1000	80	170
		2	375	235				500	150	185	
	1500	1	1500	45	85		2000	1	2000	30	50
		2	750	75				1000	50	75	
	2500	1	2500	15	25		3000	1	3000	*	*
		2	1250	25				1500	50	75	
DZ 3	50	1	50	690	460		100	1	100	690	460
		2	25					50			
	250	1	250	480	460		500	1	500	280	460
		2	125	690				250	690		
	750	1	750	215	460		1000	1	1000	110	455
		2	375	690				500	620	460	
	1500	1	1500	50	350		2000	1	2000	20	250
		2	750	450				1000	350	400	
	2500	1	2500	10	150		3000	1	3000	*	50
		2	1250	250				1500	150	250	
DZ 4	50	1	50	960	640		100	1	100	960	640
		2	25					50			
	250	1	250	650	640		500	1	500	420	595
		2	125	960				250	960	640	
	750	1	750	360	550		1000	1	1000	250	400
		2	375	960				500	780	640	
	1500	1	1500	150	225		2000	1	2000	100	150
		2	750	450				1000	300	500	
	2500	1	2500	50	80		3000	1	3000	*	*
		2	1250	230				1500	150	300	
DZ 5	50	1	50	1100	740		100	1	100	1100	740
		2	25					50			
	250	1	250	1050	740		500	1	500	870	740
		2	125	1100				250	1100		
	750	1	750	740	740		1000	1	1000	450	720
		2	375	1100				500	950	740	
	1500	1	1500	250	550		2000	1	2000	200	400
		2	750	600				1000	400	400	
	2500	1	2500	150	300		3000	1	3000	100	200
		2	1250	300				1500	200	400	

\* Contattare il servizio tecnico

\* Contact technical service

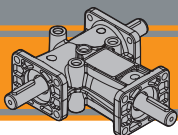

# DZ Rinvii angolari Right-angle bevel gearboxes

## Carichi radiali

## Entrata / Input

## Radial loads

Quando il carico radiale risultante non è applicato sulla mezzzeria dell'albero occorre calcolare quello effettivo con la seguente formula:

When the resulting radial load is not applied on the centre line of the shaft it is necessary to calculate the effective load with the following formula:

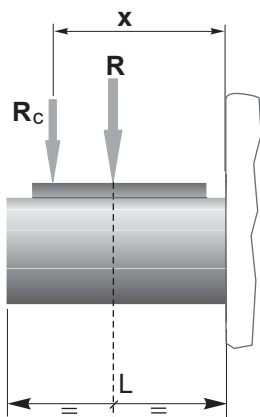

$$R_c = \frac{R \cdot a}{(b+x)} \leq R_{..MAX}$$

$$R \leq R_c$$

*a, b = valori riportati nella tabella*  
*a, b = values given in the table*

	i	a	b	R <sub>max</sub> [N]
DZ 1	1	47.5	40	140
	2			
DZ 2	1	75.5	58	330
	2			
DZ 3	1	119.5	94.5	690
	2			
DZ 4	1	131	96	960
	2			
DZ 5	1	131	96	1100
	2			

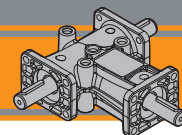

Carichi radiali e assiali

Uscita / Output

Radial and axial loads

Per carichi radiali o assiali superiori a quelli di tabella si prega di contattare il servizio tecnico

For radial or axial loads higher than those in the table, please contact technical service

	n1 [min <sup>-1</sup> ]	i	n2 [min <sup>-1</sup> ]	R <sub>1</sub> [N]	A <sub>1</sub> [N]	n1 [min <sup>-1</sup> ]	i	n2 [min <sup>-1</sup> ]	R <sub>1</sub> [N]	A <sub>1</sub> [N]
DZ 1	50	1	50	140	100	100	1	100	140	100
		2	25							
	250	1	250	140	100	500	1	500	140	100
		2	125							
	750	1	750	140	100	1000	1	1000	140	100
		2	375							
	1500	1	1500	133	85	2000	1	2000	125	75
		2	750	140	100			1000	140	100
	2500	1	2500	112	60	3000	1	3000	100	50
		2	1250	120	100			1500		100
DZ 2	50	1	50	330	220	100	1	100	330	220
		2	25							
	250	1	250	330	220	500	1	500	330	220
		2	125							
	750	1	750	330	220	1000	1	1000	330	220
		2	375							
	1500	1	1500	290	195	2000	1	2000	250	175
		2	750	330	220			1000	330	220
	2500	1	2500	225	160	3000	1	3000	200	150
		2	1250	330	220			1500	330	220
DZ 3	50	1	50	690	460	100	1	100	690	460
		2	25							
	250	1	250	690	460	500	1	500	690	460
		2	125							
	750	1	750	690	460	1000	1	1000	670	460
		2	375					690		
	1500	1	1500	550	430	2000	1	2000	450	400
		2	750	690	460			1000	690	460
	2500	1	2500	375	350	3000	1	3000	300	300
		2	1250	690	460			1500	690	460
DZ 4	50	1	50	960	640	100	1	100	960	640
		2	25							
	250	1	250	960	640	500	1	500	960	640
		2	125							
	750	1	750	960	640	1000	1	1000	880	640
		2	375					960		
	1500	1	1500	700	570	2000	1	2000	600	500
		2	750	960	640			1000	960	640
	2500	1	2500	500	400	3000	1	3000	400	300
		2	1250	960	640			1500	960	640
DZ 5	50	1	50	1100	740	100	1	100	1100	740
		2	25							
	250	1	250	1100	740	500	1	500	1100	740
		2	125							
	750	1	750	1100	740	1000	1	1000	1100	740
		2	375							
	1500	1	1500	920	670	2000	1	2000	700	600
		2	750	1100	740			1000	1100	740
	2500	1	2500	600	500	3000	1	3000	500	400
		2	1250	1100	740			1500	1100	740

DZ

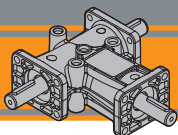

# DZ Rinvii angolari Right-angle bevel gearboxes

## Carichi radiali

## Uscita / Output

## Radial loads

Quando il carico radiale risultante non è applicato sulla mezzeria dell'albero occorre calcolare quello effettivo con la seguente formula:

When the resulting radial load is not applied on the centre line of the shaft it is necessary to calculate the effective load with the following formula:

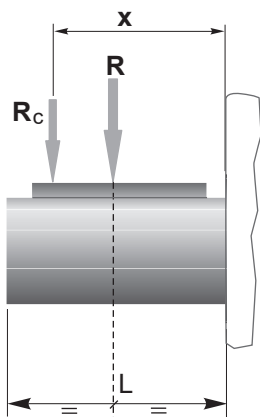

$$R_c = \frac{R \cdot a}{(b+x)} \leq R_{..MAX}$$

$$R \leq R_c$$

*a, b = valori riportati nella tabella*  
*a, b = values given in the table*

	i	a	b	R <sub>max</sub> [N]
DZ 1	1	61.5	54	140
	2			
DZ 2	1	102	84.5	330
	2			
DZ 3	1	145.5	120.5	690
	2			
DZ 4	1	169	134	960
	2			
DZ 5	1	169	134	1100
	2			



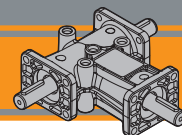

### Dati tecnici

### Technical data

	i	n <sub>1</sub>	n <sub>2</sub>	M <sub>n2</sub>	P <sub>n1</sub>	n <sub>1</sub>	n <sub>2</sub>	M <sub>n2</sub>	P <sub>n1</sub>	n <sub>1</sub>	n <sub>2</sub>	M <sub>n2</sub>	P <sub>n1</sub>	n <sub>1</sub>	n <sub>2</sub>	M <sub>n2</sub>	P <sub>n1</sub>	n <sub>1</sub>	n <sub>2</sub>	M <sub>n2</sub>	P <sub>n1</sub>
		[min <sup>-1</sup> ]	[min <sup>-1</sup> ]	[Nm]	[kW]	[min <sup>-1</sup> ]	[min <sup>-1</sup> ]	[Nm]	[kW]	[min <sup>-1</sup> ]	[min <sup>-1</sup> ]	[Nm]	[kW]	[min <sup>-1</sup> ]	[min <sup>-1</sup> ]	[Nm]	[kW]	[min <sup>-1</sup> ]	[min <sup>-1</sup> ]	[Nm]	[kW]
<b>DZ 1</b>	1	50	50	4.7	0.02	100	100	3.9	0.04	250	250	3.0	0.08	500	500	2.6	0.13	750	750	2.4	0.18
	2		25	3.6	0.01		50	3.5	0.02		125	3.1	0.04		250	2.7	0.07		375	2.5	0.09
	1	1000	1000	2.1	0.21	1500	1500	1.9	0.29	2000	2000	1.8	0.36	2500	2500	1.75	0.44	3000	3000	1.7	0.51
	2		500	2.2	0.11		750	1.9	0.14		1000	1.8	0.18		1250	1.75	0.22		1500	1.7	0.26
<b>DZ 2</b>	1	50	50	16.5	0.08	100	100	14	0.14	250	250	10.5	0.26	500	500	9.0	0.45	750	750	8.5	0.64
	2		25	15	0.04		50	15	0.08		125	11	0.14		250	9.5	0.24		375	9.1	0.34
	1	1000	1000	7.5	0.75	1500	1500	6.9	1.04	2000	2000	6.6	1.33	2500	2500	6.2	1.56	3000	3000	5.9	1.78
	2		500	8.0	0.40		750	6.9	0.52		1000	6.5	0.65		1250	6.4	0.80		1500	6.3	0.95
<b>DZ 3</b>	1	50	50	53	0.27	100	100	45	0.45	250	250	34	0.85	500	500	30	1.51	750	750	29	2.15
	2		25	39	0.10		50	37	0.19		125	33	0.41		250	28	0.70		375	26.5	1.00
	1	1000	1000	25	2.51	1500	1500	22	3.32	2000	2000	21	4.22	2500	2500	20	5.03	3000	3000	19	5.73
	2		500	23.2	1.17		750	20.5	1.55		1000	20	2.01		1250	19.5	2.45		1500	19	2.86
<b>DZ 4</b>	1	50	50	87	0.44	100	100	74	0.74	250	250	56	1.41	500	500	49	2.46	750	750	46	3.47
	2		25	90	0.23		50	82	0.41		125	63.5	0.80		250	55	1.38		375	52	1.96
	1	1000	1000	41	4.12	1500	1500	36	5.43	2000	2000	35	7.04	2500	2500	33	8.29	3000	3000	31	9.35
	2		500	45	2.26		750	39	2.94		1000	37	3.72		1250	36.3	4.56		1500	35	5.28
<b>DZ 5</b>	1	50	50	120	0.60	100	100	100	1.01	250	250	78	1.96	500	500	66	3.32	750	750	63	4.75
	2		25	95	0.24		50	90	0.45		125	78	0.98		250	67	1.68		375	63	2.37
	1	1000	1000	56	5.63	1500	1500	50	7.54	2000	2000	48	9.65	2500	2500	46	11.56	3000	3000	43	12.97
	2		500	55	2.76		750	47.5	3.58		1000	45	4.52		1250	43.5	5.47		1500	42	6.33

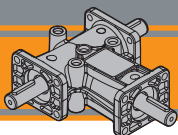

# DZ Rinvii angolari Right-angle bevel gearboxes

Dimensioni

Dimensions

## DZ 1 ... 2F ...

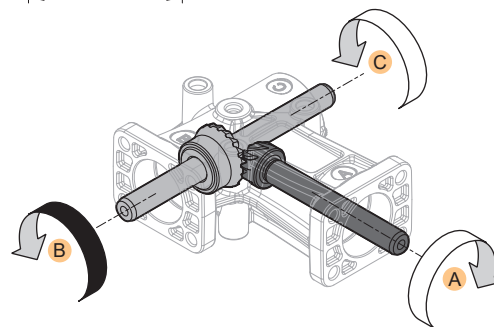
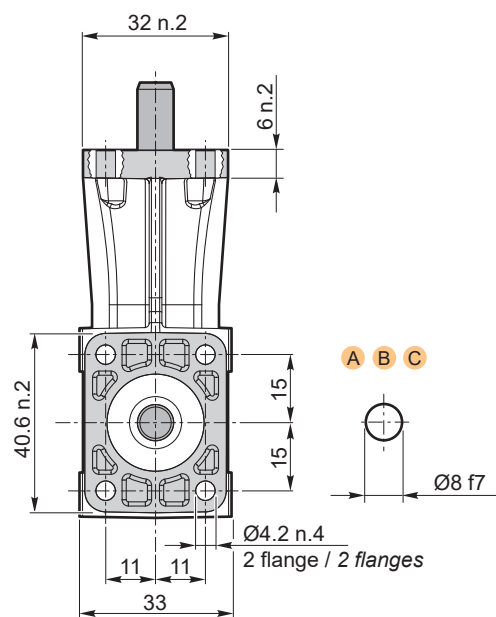
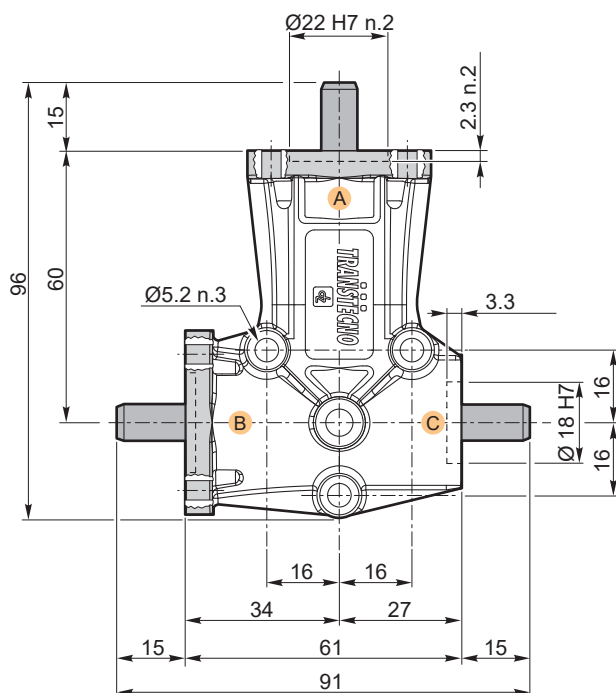

i	Code	Kg
1	DZ 11 2F ABC	0.3
2	DZ 13 2F ABC	

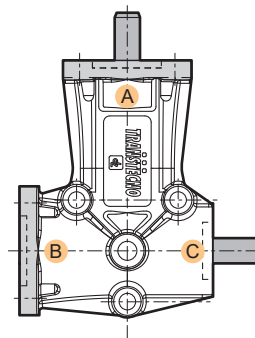
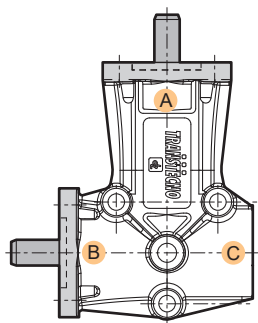

i	Code	Kg
1	DZ 10 S 2F AB	0.3
2	DZ 12 S 2F AB	

i	Code	Kg
1	DZ 10 FS 2F AC	0.3
2	DZ 12 FS 2F AC	

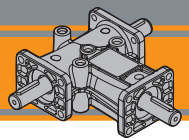

Dimensioni

Dimensions

DZ 1... 3F ...

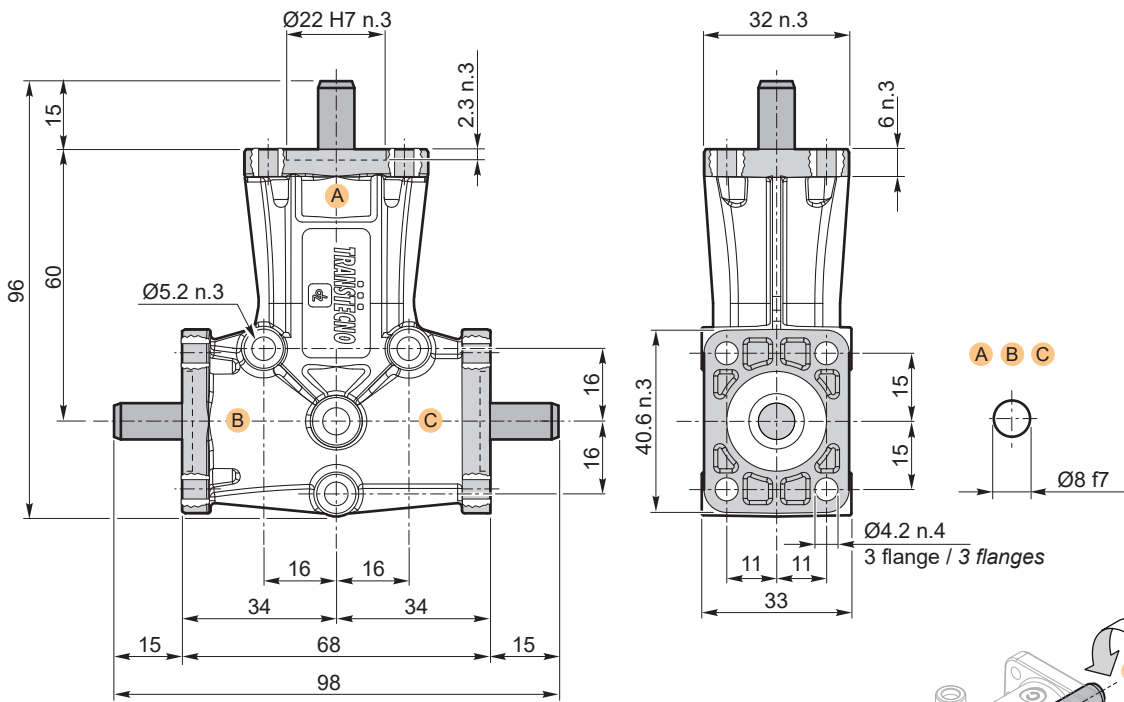

i	Code	Kg
1	DZ 11 3F ABC	0.3
2	DZ 13 3F ABC	

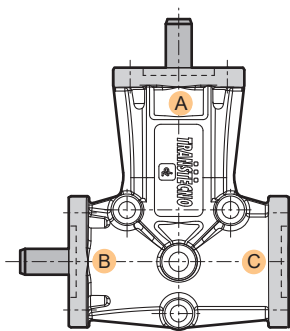

i	Code	Kg
1	DZ 10 S 3F AB	0.3
2	DZ 12 S 3F AB	

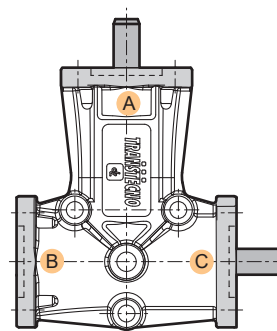

i	Code	Kg
1	DZ 10 FS 3F AC	0.3
2	DZ 12 FS 3F AC	

DZ



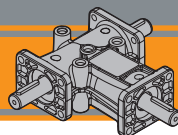

Dimensioni

Dimensions

DZ 2 ... 3F ...

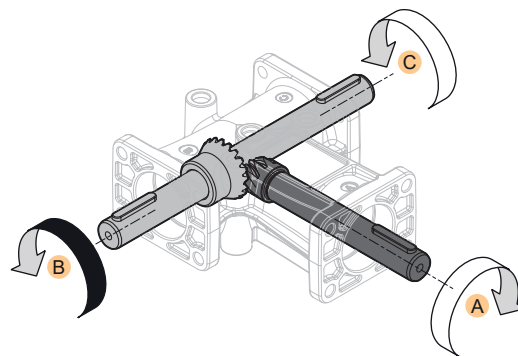
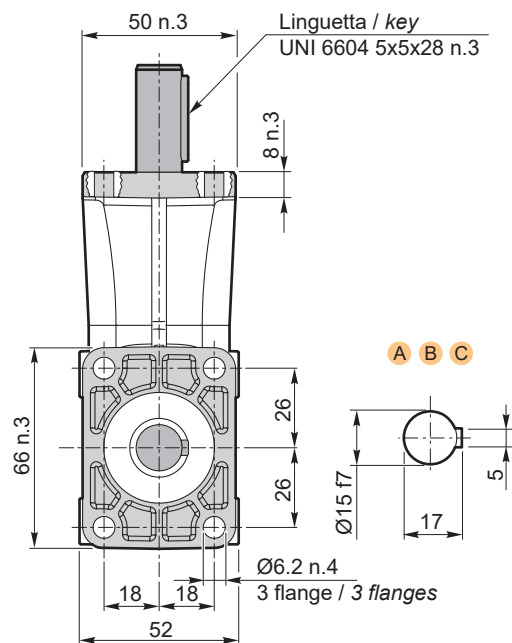
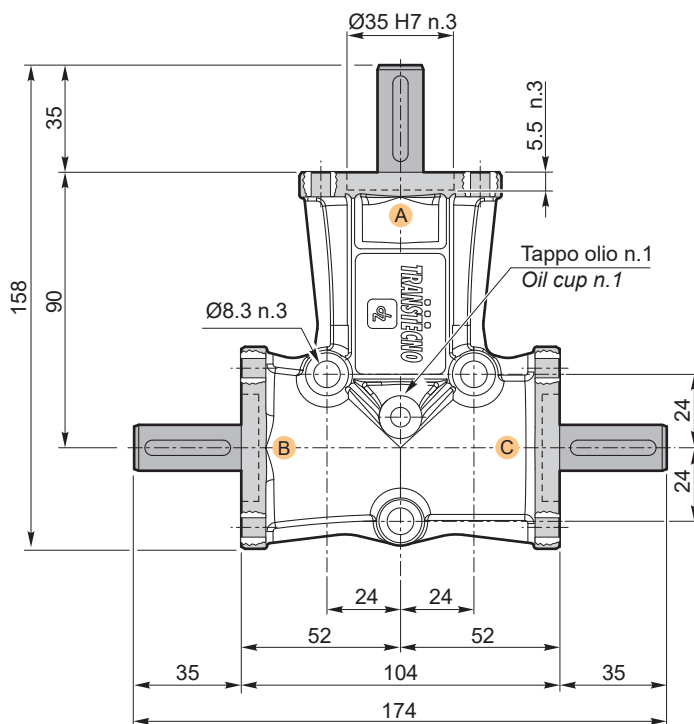

i	Code	Kg
1	DZ 21 3F ABC	1.2
2	DZ 23 3F ABC	

Le sedi linguetta negli alberi cavi come negli alberi maschi possono assumere qualsiasi posizione angolare.

The keyways in hollow shafts as in solid shafts can assume any angular position.

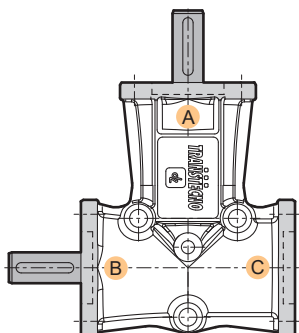

i	Code	Kg
1	DZ 20 S 3F AB	1.1
2	DZ 22 S 3F AB	

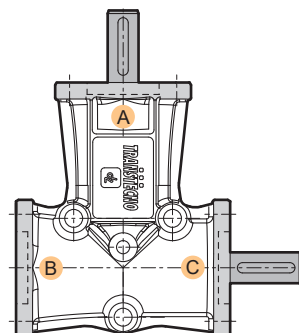

i	Code	Kg
1	DZ 20 FS 3F AC	1.1
2	DZ 22 FS 3F AC	

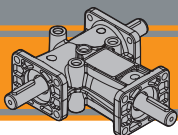

# DZ Rinvii angolari Right-angle bevel gearboxes

Dimensioni

Dimensions

## DZ 3 ... 3F ...

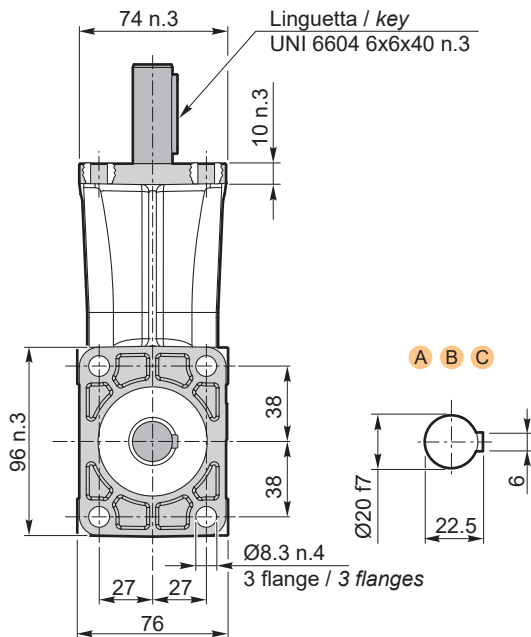
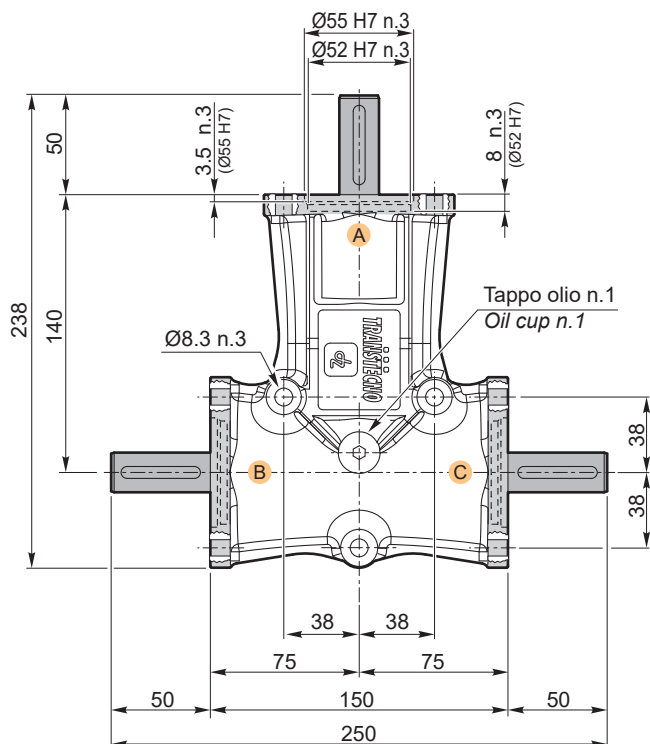

i	Code	Kg
1	DZ 31 3F ABC	3.5
2	DZ 33 3F ABC	

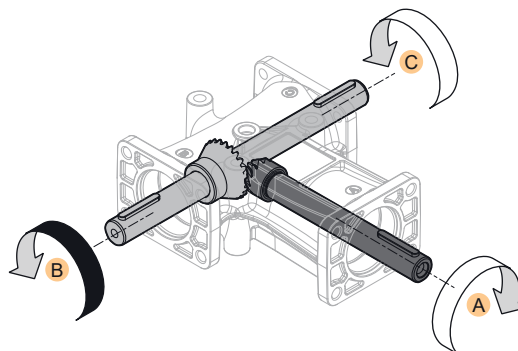

Le sedi linguetta negli alberi cavi come negli alberi maschi possono assumere qualsiasi posizione angolare.

The keyways in hollow shafts as in solid shafts can assume any angular position.

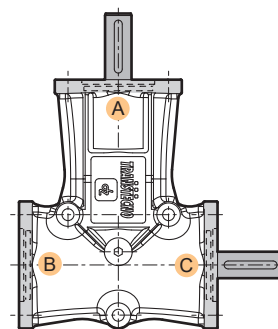
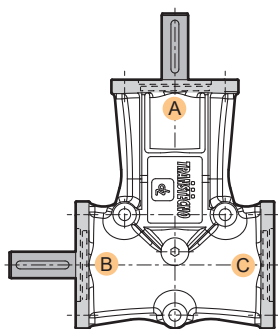

i	Code	Kg
1	DZ 30 S 3F AB	3.4
2	DZ 32 S 3F AB	

i	Code	Kg
1	DZ 30 FS 3F AC	3.4
2	DZ 32 FS 3F AC	

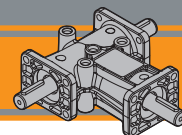

Dimensioni

Dimensions

DZ 3 ... 3F ... albero cavo / hollow shaft

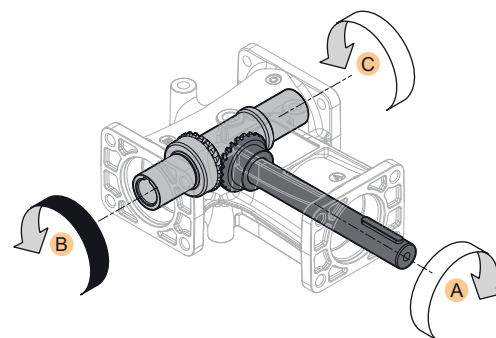
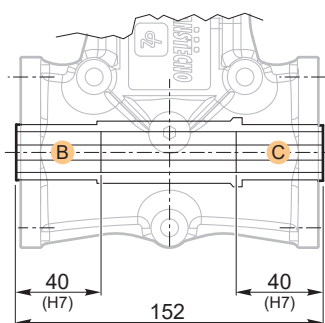
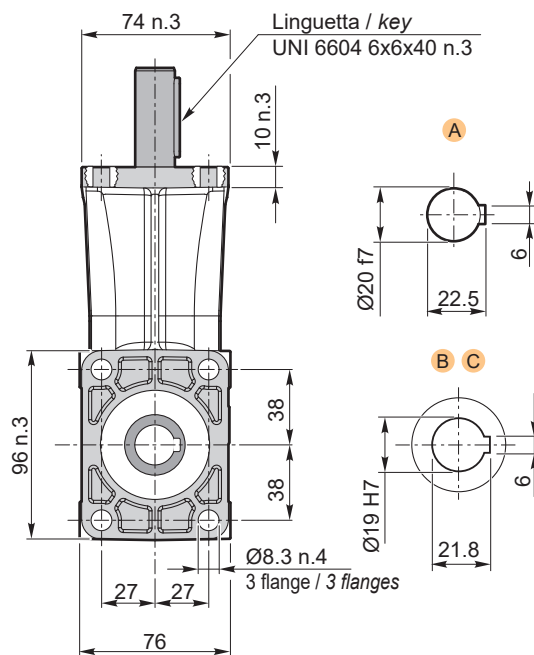
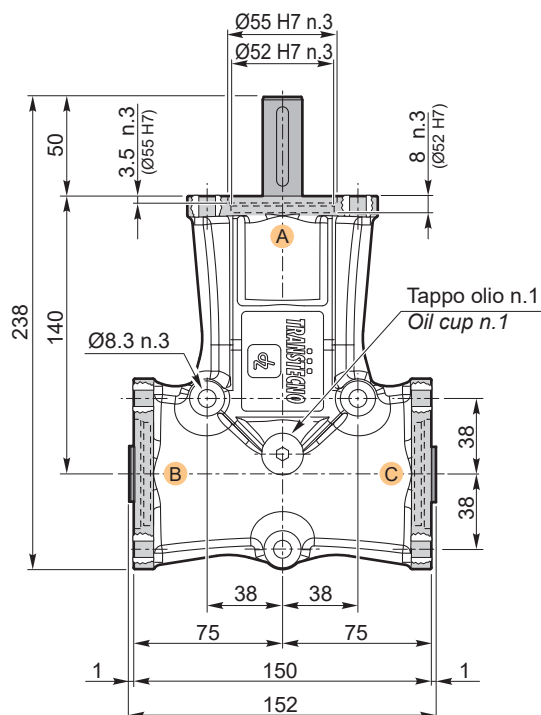

Le sedi linguetta negli alberi cavi come negli alberi maschi possono assumere qualsiasi posizione angolare.

The keyways in hollow shafts as in solid shafts can assume any angular position.

i	Code	Kg
1	DZ 311 3F ABC	3.3

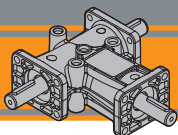

# DZ Rinvii angolari Right-angle bevel gearboxes

Dimensioni

Dimensions

## DZ 4 ... 3F ...

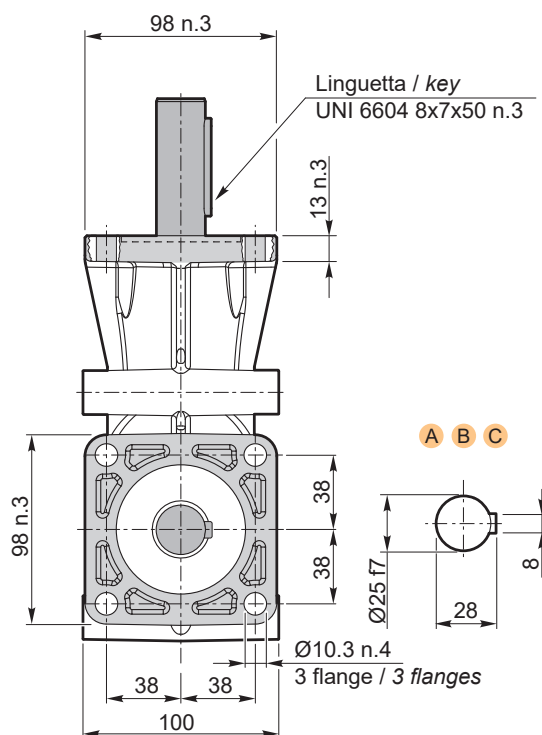
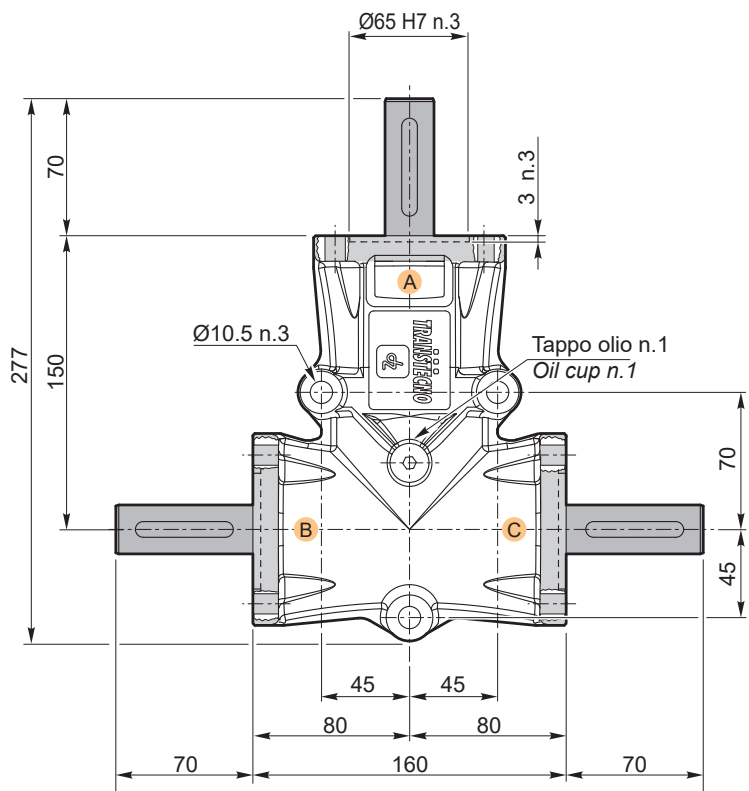

i	Code	Kg
1	DZ 41 3F ABC	5.8
2	DZ 43 3F ABC	

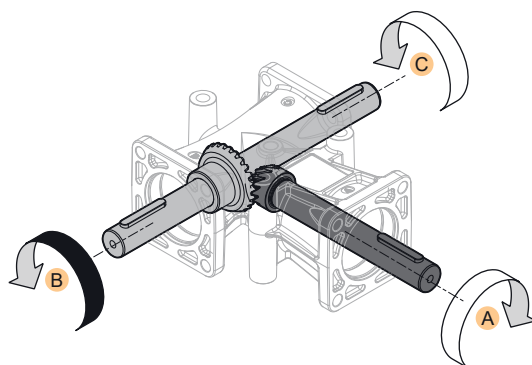

Le sedi linguetta negli alberi cavi come negli alberi maschi possono assumere qualsiasi posizione angolare.

The keyways in hollow shafts as in solid shafts can assume any angular position.

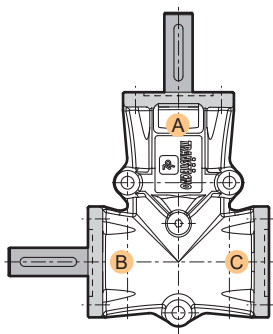

i	Code	Kg
1	DZ 40 S 3F AB	5.5
2	DZ 42 S 3F AB	

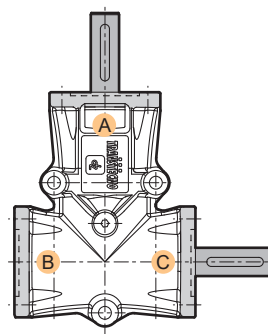

i	Code	Kg
1	DZ 40 FS 3F AC	5.5
2	DZ 42 FS 3F AC	



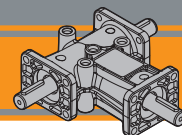

Dimensioni

Dimensions

DZ 5 ... 3F ...

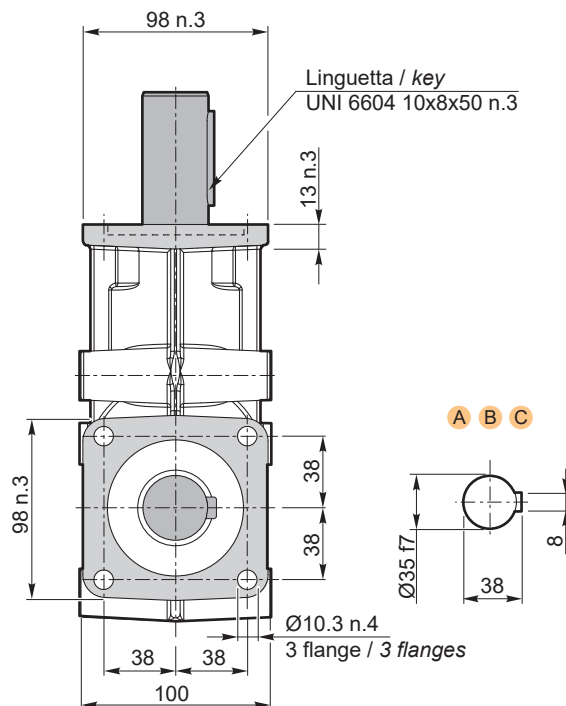
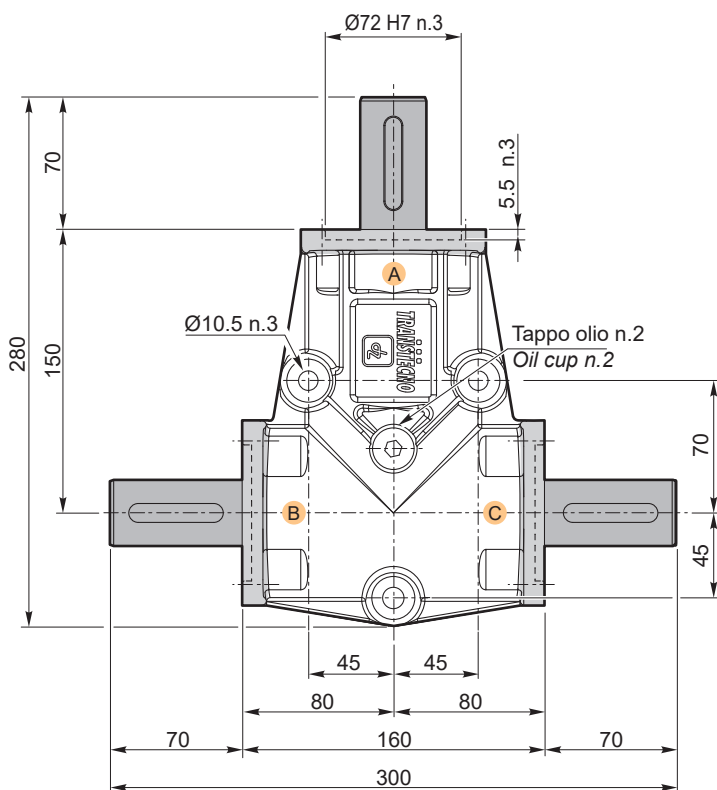

i	Code	Kg
1	DZ 51 3F ABC	8.8
2	DZ 53 3F ABC	

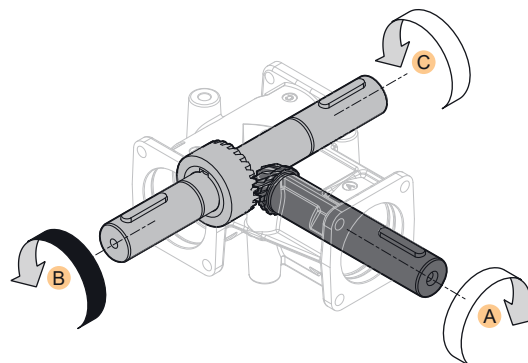

Le sedi linguetta negli alberi cavi come negli alberi maschi possono assumere qualsiasi posizione angolare.

The keyways in hollow shafts as in solid shafts can assume any angular position.

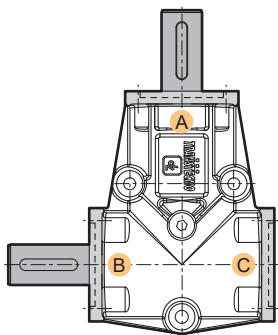

i	Code	Kg
1	DZ 50 S 3F AB	8.1
2	DZ 52 S 3F AB	

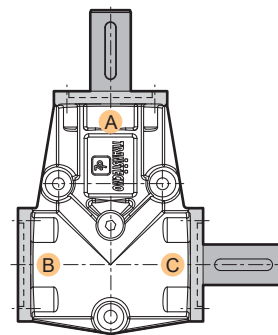

i	Code	Kg
1	DZ 50 FS 3F AC	8.1
2	DZ 52 FS 3F AC	

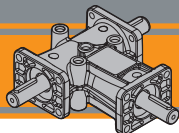

# Note/Notes

---

---

---

---

---

---

---

---

---

---

---

---

---

---

---

---

---

---

---

---

---

---

---

---

---

---

---

---

---



Rinvii angolari  
**Right-angle bevel gearboxes**





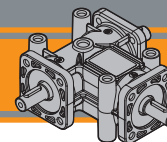

<b>Indice</b>	<b>Index</b>	Pag. Page
Caratteristiche tecniche	<i>Technical features</i>	<b>C2</b>
Designazione	<i>Classification</i>	<b>C3</b>
Versione	<i>Version</i>	<b>C3</b>
Sensi di rotazione	<i>Direction of rotation</i>	<b>C4</b>
Simbologia	<i>Symbols</i>	<b>C4</b>
Lubrificazione	<i>Lubrication</i>	<b>C4</b>
Carichi radiali e assiali	<i>Radial and axial loads</i>	<b>C5</b>
Dati tecnici	<i>Technical data</i>	<b>C9</b>
Dimensioni	<i>Dimensions</i>	<b>C10</b>

Questa sezione annulla e sostituisce ogni precedente edizione o revisione. Qualora questa sezione non Vi sia giunta in distribuzione controllata, l'aggiornamento dei dati ivi contenuto non è assicurato. **In tal caso la versione più aggiornata è disponibile sul nostro sito internet [www.transtecno.com](http://www.transtecno.com)**

*This section replaces any previous edition and revision. If you obtained this catalogue other than through controlled distribution channels, the most up to date content is not guaranteed. In this case the latest version is available on our web site [www.transtecno.com](http://www.transtecno.com)*

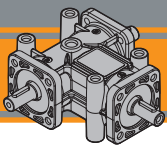

# ZP Rinvii angolari Right-angle bevel gearboxes

## Caratteristiche tecniche

## Technical features

I rinvii angolari serie ZP sono stati progettati per applicazioni industriali dove occorre trasmettere un moto rotatorio tra alberi disposti perpendicolarmente tra loro.

Sono disponibili:

- 4 grandezze: ZP1 ZP2, ZP3 e ZP4
- 3 rapporti: 1/1 , 1/2 e 1/3 (dalla grandezza 2)
- 2 o 1 prese moto uscita;
- 1 flangia ingresso e 2 flange uscita.
- 2 flange ingresso e 2 flange uscita solo per ZP2

Caratteristiche comuni a tutta la serie sono:

- Carter monoblocco in lega di alluminio predisposta per il fissaggio in 4 punti o ,in alternativa, alle flange in corrispondenza delle prese moto
- Coppia Conica Spiroidale GLEASON in acciaio al Nickel Cromo con trattamento di Cementazione - Tempra
- Alberi maschio in acciaio al carbonio protetti superficialmente contro la corrosione con trattamento di fosfatazione .Le sedi linguetta (non presenti sulla taglia ZP1) possono assumere qualsiasi posizione angolare
- Sulle taglie ZP2 e ZP3 è previsto un albero uscita cavo con sede linguetta
- Cuscinetti radiali a sfere
- Anelli di Tenuta tipo A in NBR o Tappi in NBR ove l'albero non è sporgente
- Lubrificazione con olio sintetico ISO 150, ad esclusione delle grandezze 1 fornita con grasso minerale 00 EP permanente

ZP-series right-angle bevel gearboxes are designed for industrial applications where rotary motion must be transmitted between perpendicularly arranged shafts.

Those available:

- 4 sizes: ZP1 ZP2, ZP3 and ZP4
- 3 ratios: 1/1 , 1/2 and 1/3 (from size 2)
- 2 or 1 output power take-off;
- 1 input flange and 2 output flanges.
- 2 input and 2 output flanges only for ZP2

Common features throughout the series are:

- One-piece aluminium alloy casing prepared for 4-point fixing or, alternatively, to flanges at the power take-off
- GLEASON spiral bevel gear in Nickel Chrome steel with Case hardening treatment
- Solid shafts in carbon steel, surface protected against corrosion with phosphating treatment. Feather key seats (not present on size ZP1) can assume any angular position
- On sizes ZP2 and ZP3 a hollow output shaft with keyway is provided
- Radial ball bearings
- NBR type A sealing rings or NBR plugs where the shaft does not protrude
- Lubrication with synthetic oil ISO 150, except size 1 supplied with permanent 00 EP mineral grease

**C** Asse uscita: lato opposto montaggio corona  
Output axis: side opposite gear mounting



**D** Asse uscita: lato opposto montaggio corona  
Output axis: side opposite gear mounting

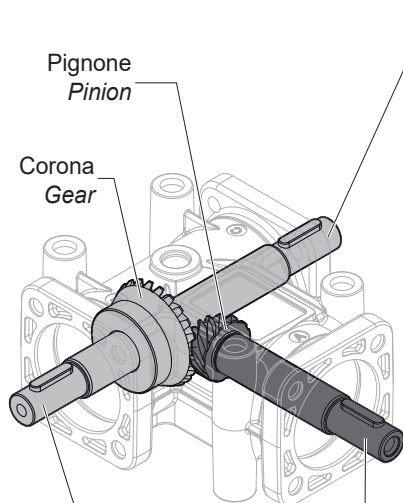

**C** Asse entrata: lato montaggio pignone  
Input axis: pinion mounting side

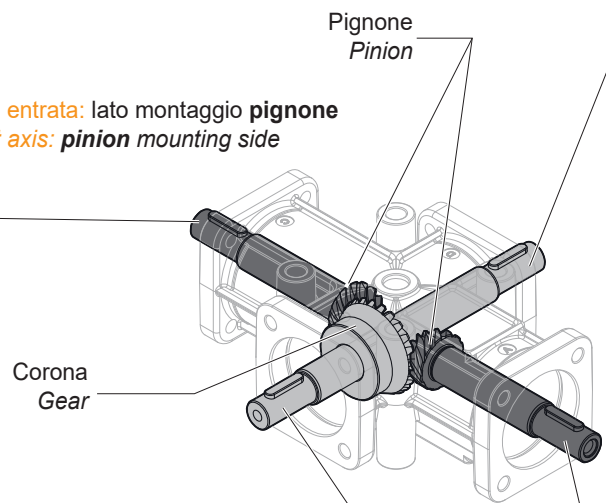

**B** Asse uscita: lato montaggio corona  
Output axis: gear mounting side

**A** Asse entrata: lato montaggio pignone  
Input axis: pinion mounting side

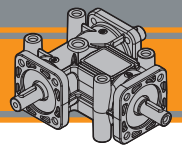

## Designazione

## Classification

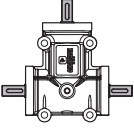
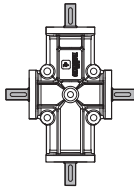
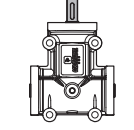
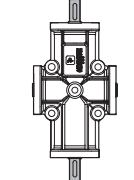
RINVIO ANGOLORE / RIGHT-ANGLE BEVEL GEARBOX								
ZP	1	0	S	4P	A	B	-	-
Tipo Type	Grandezza Size	Rapporto Ratio	Tipo di montaggio Mounting type	Flangia Flange	Albero in A Shaft in A	Albero in B Shaft in B	Albero in C Shaft in C	Albero in C Shaft in C
<b>ZP</b> 	1 2 3 4	0 - 1 (i = 1/1) 2 - 3 (i = 1/2) 4 - 5 (i = 1/3)	<b>S</b>  <b>FS</b>  ...	<b>4P</b>	<b>A</b>	<b>B</b>	<b>C</b>	<b>D</b>
	2	20 - 21 (i = 1/1) 22 - 23 (i = 1/2) 24 - 25 (i = 1/3) ZP2 - 4 vie ZP2 - 4 shafts						
	2 3	11 (i = 1/1) 13 (i = 1/2) 15 (i = 1/3) Albero cavo Hollow shaft				3V		
	2					4V		

**ZP**

## Versione

## Version

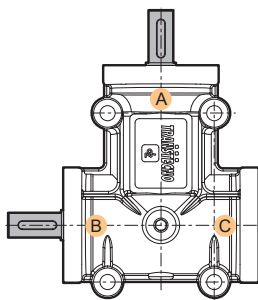

S..AB

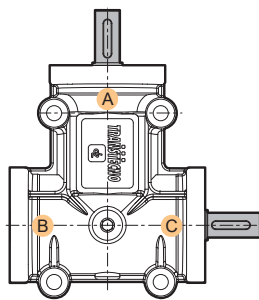

FS..AC

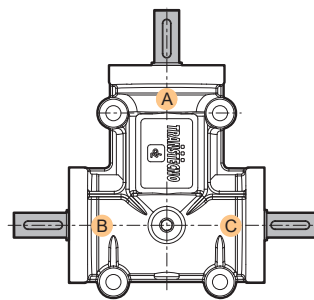

...ABC

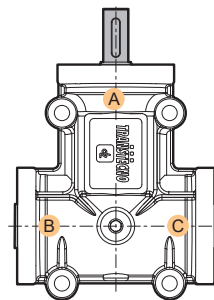

...3V

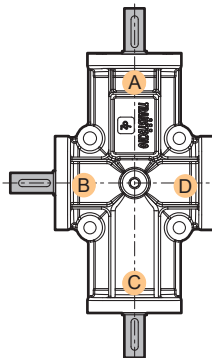

S..ABC

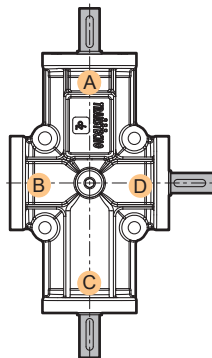

FS..ACD

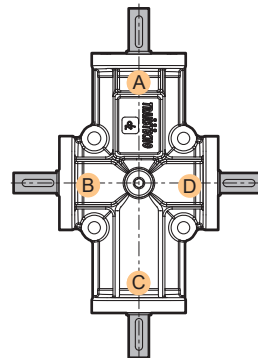

...ABCD

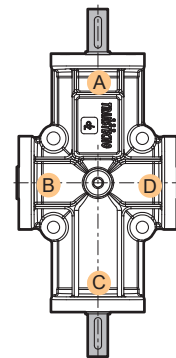

...4V

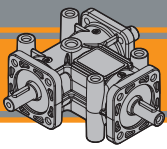

## Sensi di rotazione

## Direction of rotation

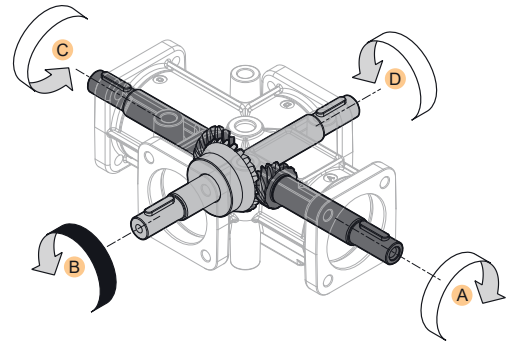
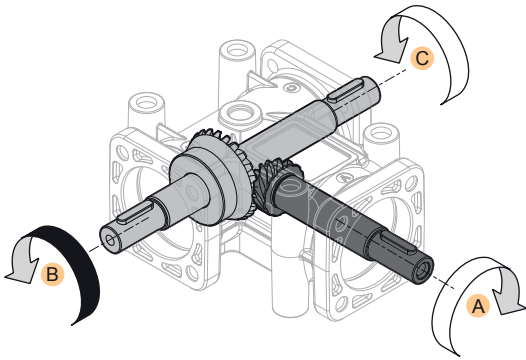

## Simbologia

## Symbols

$n_1$	[ $\text{min}^{-1}$ ]	Velocità in ingresso / <i>Input speed</i>
$n_2$	[ $\text{min}^{-1}$ ]	Velocità in uscita / <i>Output speed</i>
$i$		Rapporto di riduzione / <i>Ratio</i>
$P_1$	[kW]	Potenza in entrata / <i>Input power</i>
$M_2$	[Nm]	Coppia nominale in uscita in funzione di $P_1$ / <i>Output torque referred to <math>P_1</math></i>
$P_{n1}$	[kW]	Potenza nominale in entrata / <i>Nominal input power</i>
$M_{n2}$	[Nm]	Coppia nominale in uscita in funzione di $P_{n1}$ / <i>Nominal output torque referred to <math>P_{n1}</math></i>
$sf$		Fattore di servizio / <i>Service factor</i>
$R_1$	[N]	Carico radiale ammissibile in entrata / <i>Permitted input radial load</i>
$A_1$	[N]	Carico assiale ammissibile in entrata / <i>Permitted input axial load</i>
$R_2$	[N]	Carico radiale ammissibile in uscita / <i>Permitted output radial load</i>
$A_2$	[N]	Carico assiale ammissibile in uscita / <i>Permitted output axial load</i>
 $kg$	[kg]	Peso del solo riduttore / <i>Weight of the gearbox only</i>

## Lubrificazione

## Lubrication

I rinvii angolari serie ZP, sono forniti completi di lubrificante sintetico ISO 150, ad esclusione della grandezza 1 fornita con grasso minerale 00 EP.

*ZP-series right-angle bevel gearboxes are supplied complete with synthetic lubricant ISO 150, except size 1 supplied with 00 EP mineral grease.*

Possono essere installati in qualunque posizione di montaggio e non necessitano di manutenzione.

*They can be installed in any mounting position and are maintenance-free.*



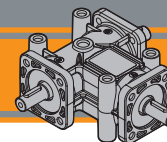

### Carichi radiali e assiali

### Entrata / Input

### Radial and axial loads

Per carichi radiali o assiali superiori a quelli di tabella si prega di contattare il servizio tecnico

For radial or axial loads higher than those in the table, please contact technical service

	n1 [min <sup>-1</sup> ]	i	n2 [min <sup>-1</sup> ]	R <sub>1</sub> [N]	A <sub>1</sub> [N]		n1 [min <sup>-1</sup> ]	i	n2 [min <sup>-1</sup> ]	R <sub>1</sub> [N]	A <sub>1</sub> [N]
ZP 1	50	1	50	200	160	ZP 1	100	1	100	200	160
		2	25					50			
	250	1	250	150	160		500	1	500	82	160
		2	125	200				250			
	750	1	750	65	160		1000	1	1000	35	140
		2	375	200				500	200	160	
1500	1	1500	15	85	2000	1	2000	10	50		
	2	750	200	160		2	1000	200	160		
2500	1	2500	5	25	3000	1	3000	*	*		
	2	1250	175	160		2	1500	150	160		
ZP 2	50	1	50	520	420	ZP 2	100	1	100	520	420
		2	25					50			
		3	17					33			
	250	1	250	520	420		500	1	500	450	420
		2	125					480	410		
		3	83					167	520	420	
750	1	750	375	420	1000	1	1000	250	410		
	2	375	440	405		2	500	300	300		
	3	250	520	420		3	333	510	420		
1500	1	1500	150	300	2000	1	2000	100	200		
	2	750		150		100					
	3	500		450		360	300				
2500	1	2500	50	100	3000	1	3000	*	*		
	2	1250		50		50					
	3	833		350		275	300		250		
ZP 3	50	1	50	960	640	ZP 3	100	1	100	960	640
		2	25					50			
		3	17					33			
	250	1	250	735	570		500	1	500	360	400
		2	125	960	640			2	250	960	640
		3	83								
750	1	750	230			300	1000	1	1000		
	2	375	960	640	2	500		780	520		
	3	250			333	960		640			
1500	1	1500			*	75	2000	1	2000	*	50
	2	750	400	300	2	1000		200	200		
	3	500	960	640	3	667		960	640		
2500	1	2500	*	25	3000	1	3000	*	*		
	2	1250	100	100		2	1500	*	*		
	3	833	960	640		3	1000	960	640		
ZP 4	50	1	50	960	640	ZP 4	100	1	100	960	640
		2	25					50			
		3	17					33			
	250	1	250	740	620		500	1	500	400	500
		2	125	960	640			2	250	960	640
		3	83								
750	1	750	300			400	1000	1	1000		
	2	375	960	640	2	500		730	520		
	3	250			333	960		640			
1500	1	1500			75	150	2000	1	2000	50	100
	2	750	350	300	2	1000		200	200		
	3	500	960	640	3	667		960	640		
2500	1	2500	*	50	3000	1	3000	*	*		
	2	1250	100	100		2	1500	*	*		
	3	833	960	640		3	1000	960	640		

\* Contattare il servizio tecnico

\* Contact technical service

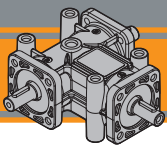

# ZP Rinvii angolari Right-angle bevel gearboxes

## Carichi radiali

## Entrata / Input

## Radial loads

Quando il carico radiale risultante non è applicato sulla mezzeria dell'albero occorre calcolare quello effettivo con la seguente formula:

When the resulting radial load is not applied on the centre line of the shaft it is necessary to calculate the effective load with the following formula:

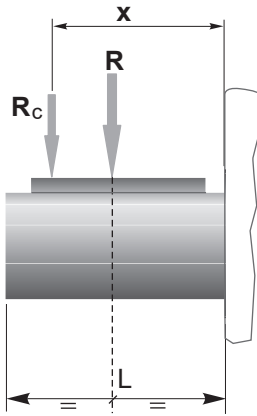

$$R_c = \frac{R \cdot a}{(b+x)} \leq R_{..MAX}$$

$$R \leq R_c$$

*a, b = valori riportati nella tabella*  
*a, b = values given in the table*

	i	a	b	R <sub>max</sub> [N]
ZP 1	1	49	39	200
	2			
ZP 2	1	70	55	520
	2			
	3			
ZP 3	1	107	87	960
	2			
	3			
ZP 4	1	112	87	960
	2			
	3			

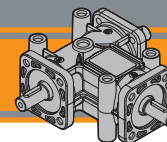

### Carichi radiali e assiali

### Uscita / Output

### Radial and axial loads

Per carichi radiali o assiali superiori a quelli di tabella si prega di contattare il servizio tecnico

For radial or axial loads higher than those in the table, please contact technical service

	n1 [min <sup>-1</sup> ]	i	n2 [min <sup>-1</sup> ]	ZP 1		n1 [min <sup>-1</sup> ]	i	n2 [min <sup>-1</sup> ]	ZP 2		n1 [min <sup>-1</sup> ]	i	n2 [min <sup>-1</sup> ]	ZP 3		n1 [min <sup>-1</sup> ]	i	n2 [min <sup>-1</sup> ]	ZP 4								
				R <sub>1</sub> [N]	A <sub>1</sub> [N]				R <sub>1</sub> [N]	A <sub>1</sub> [N]				R <sub>1</sub> [N]	A <sub>1</sub> [N]				R <sub>1</sub> [N]	A <sub>1</sub> [N]							
50	1	50	200	160	200	1	100	200	160	200	1	500	200	160	200	1	1000	200	160								
																				2	25	2	50	2	250	2	500
250	1	250	200	160	200	1	500	200	160	200	1	1000	200	160	200	1	2000	100	100								
																				2	125	2	500	2	1000	2	2000
750	1	750	200	160	200	1	3000	50	50	200	1	1500	200	160	200	1	750	150	130								
																				2	375	2	500	2	1000	2	2000
1500	1	1500	150	130	200	1	2000	100	100	200	1	3000	50	50	200	1	2500	75	75								
																				2	750	2	1000	2	2000	2	1250
2500	1	2500	75	75	200	1	3000	50	50	200	1	1500	200	160	200	1	2500	75	75								
																				2	1250	2	1500	2	200	2	1250
50	1	50	520	420	520	1	100	520	420	520	1	500	520	420	520	1	1500	510	410								
																				2	25	2	500	2	1000	2	500
																				3	17	3	33	3	333	3	667
250	1	250	520	420	520	1	500	520	420	520	1	1000	520	420	520	1	2500	400	325								
																				2	125	2	500	2	1000	2	500
																				3	83	3	667	3	1000	3	833
750	1	750	520	420	520	1	1000	520	420	520	1	3000	300	250	520	1	2500	400	325								
																				2	375	2	1000	2	500	2	500
																				3	250	3	333	3	1000	3	833
1500	1	1500	510	410	520	1	2000	500	400	520	1	3000	300	250	520	1	2500	400	325								
																				2	750	2	1000	2	500	2	500
																				3	500	3	667	3	1000	3	833
2500	1	2500	400	325	520	1	3000	300	250	520	1	1500	200	160	200	1	2500	75	75								
																				2	1250	2	1500	2	500	2	500
																				3	833	3	1000	3	833		
50	1	50	960	640	960	1	100	960	640	960	1	500	960	640	960	1	1500	700	570								
																				2	25	2	500	2	1000	2	500
																				3	17	3	167	3	333	3	667
250	1	250	960	640	960	1	500	960	640	960	1	1000	880	640	960	1	2500	500	400								
																				2	125	2	500	2	500	2	500
																				3	83	3	167	3	333	3	667
750	1	750	960	640	960	1	1000	880	640	960	1	3000	400	300	960	1	2500	500	400								
																				2	375	2	500	2	500	2	500
																				3	250	3	333	3	1000	3	833
1500	1	1500	700	570	960	1	2000	600	500	960	1	3000	400	300	960	1	2500	500	400								
																				2	750	2	1000	2	500	2	500
																				3	500	3	667	3	1000	3	833
2500	1	2500	500	400	960	1	3000	400	300	960	1	1500	200	160	200	1	2500	75	75								
																				2	1250	2	1500	2	500	2	500
																				3	833	3	1000	3	833		
50	1	50	960	640	960	1	100	960	640	960	1	500	960	640	960	1	1500	750	570								
																				2	25	2	500	2	1000	2	500
																				3	17	3	167	3	333	3	667
250	1	250	960	640	960	1	500	960	640	960	1	1000	930	640	960	1	2500	500	400								
																				2	125	2	500	2	500	2	500
																				3	83	3	167	3	333	3	667
750	1	750	960	640	960	1	1000	930	640	960	1	3000	400	300	960	1	2500	500	400								
																				2	375	2	500	2	500	2	500
																				3	250	3	333	3	1000	3	833
1500	1	1500	750	570	960	1	2000	600	500	960	1	3000	400	300	960	1	2500	500	400								
																				2	750	2	1000	2	500	2	500
																				3	500	3	667	3	1000	3	833
2500	1	2500	500	400	960	1	3000	400	300	960	1	1500	200	160	200	1	2500	75	75								
																				2	1250	2	1500	2	500	2	500
																				3	833	3	1000	3	833		

Per le versioni con albero uscita CAVO ZP211.., ZP213.., ZP215.. e ZP311.., ZP313.. e ZP315 contattare il servizio tecnico

For versions with HOLLOW output shaft ZP211.., ZP213.., ZP215.. and ZP311.., ZP313.. and ZP315 contact technical service

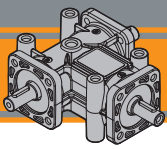

# ZP Rinvii angolari Right-angle bevel gearboxes

## Carichi radiali

## Uscita / Output

## Radial loads

Quando il carico radiale risultante non è applicato sulla mezzeria dell'albero occorre calcolare quello effettivo con la seguente formula:

When the resulting radial load is not applied on the centre line of the shaft it is necessary to calculate the effective load with the following formula:

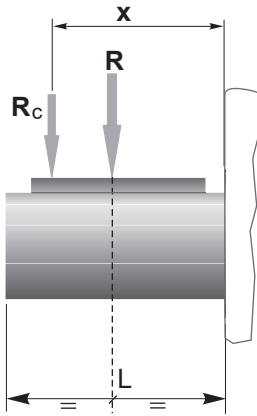

$$R_c = \frac{R \cdot a}{(b+x)} \leq R_{..MAX}$$

$$R \leq R_c$$

*a, b = valori riportati nella tabella*  
*a, b = values given in the table*

	i	a	b	R <sub>max</sub> [N]
ZP 1	1	70.5	60.5	200
	2			
ZP 2	1	107	92	520
	2			
	3			
ZP 3	1	150	130	960
	2			
	3			
ZP 4	1	155	130	960
	2			
	3			

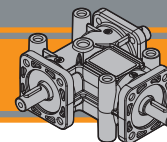

### Dati tecnici

### Technical data

	i	n <sub>1</sub> [min <sup>-1</sup> ]	n <sub>2</sub> [min <sup>-1</sup> ]	M <sub>n2</sub> [Nm]	P <sub>n1</sub> [kW]	n <sub>1</sub>		n <sub>2</sub>		M <sub>n2</sub>		P <sub>n1</sub>		n <sub>1</sub>		n <sub>2</sub>		M <sub>n2</sub>		P <sub>n1</sub>		
						[min <sup>-1</sup> ]	[min <sup>-1</sup> ]	[Nm]	[kW]	[min <sup>-1</sup> ]	[min <sup>-1</sup> ]	[Nm]	[kW]	[min <sup>-1</sup> ]	[min <sup>-1</sup> ]	[Nm]	[kW]	[min <sup>-1</sup> ]	[min <sup>-1</sup> ]	[Nm]	[kW]	
<b>ZP 1</b>	1	50	50	4.7	0.02	100	100	4.5	0.05	250	250	4.1	0.10	500	500	3.9	0.20	750	750	3.85	0.29	
	2		25	7.5	0.02		50	7.0	0.04		125	6.7	0.08		250	6.0	0.15		375	5.6	0.21	
	1	1000	1000	3.7	0.37	1500	1500	3.45	0.52	2000	2000	3.3	0.66	2500	2500	3.15	0.79	3000	3000	3.0	0.90	
	2		500	4.8	0.24		750	4.3	0.32		1000	4.2	0.42		1250	4.0	0.50		1500	3.9	0.59	
	<b>ZP 2</b>	1	50	50	19	0.10	100	100	18	0.18	250	250	17	0.41	500	500	15.7	0.79	750	750	15.2	1.15
		2		25	26	0.07		50	26	0.13		125	24.5	0.31		250	23	0.58		375	22	0.81
3		17		18	0.03	33		17.5	0.06	83		16.7	0.14	167		16.3	0.27	250		16.1	0.40	
1		1000	1000	14.7	1.48	1500	1500	14.3	2.16	2000	2000	14	2.81	2500	2500	13	3.27	3000	3000	12	3.62	
2			500	19	0.93		750	16	1.21		1000	14.5	1.46		1250	14.3	1.79		1500	14	2.11	
3			333	15	0.50		500	13.5	0.68		667	13	0.84		833	12.5	1.05		1000	12	1.21	
<b>ZP 3</b>		1	50	50	87	0.44	100	100	73	0.73	250	250	56	1.41	500	500	49	2.46	750	750	46	3.47
		2		25	90	0.23		50	82	0.41		125	63.5	0.80		250	55	1.38		375	52	1.96
		3		17	33	0.06		33	32	0.11		83	30.4	0.25		167	29.3	0.49		250	28.6	0.72
	1	1000	1000	41	4.12	1500	1500	36	5.43	2000	2000	35	7.04	2500	2500	33	8.29	3000	3000	31	9.35	
	2		500	45	2.26		750	39	2.94		1000	37	3.72		1250	36.3	4.56		1500	35	5.28	
	3		333	27	0.90		500	25.5	1.28		667	25	1.68		833	24.5	2.05		1000	24	2.41	
	<b>ZP 4</b>	1	50	50	87	0.44	100	100	73	0.73	250	250	56	1.41	500	500	49	2.46	750	750	46	3.47
		2		25	90	0.23		50	82	0.41		125	63.5	0.80		250	55	1.38		375	52	1.96
		3		17	33	0.06		33	32	0.11		83	30.4	0.25		167	29.3	0.49		250	28.6	0.72
1		1000	1000	41	4.12	1500	1500	36	5.43	2000	2000	35	7.04	2500	2500	33	8.29	3000	3000	31	9.35	
2			500	45	2.26		750	39	2.94		1000	37	3.72		1250	36.3	4.56		1500	35	5.28	
3			333	27	0.90		500	25.5	1.28		667	25	1.68		833	24.5	2.05		1000	24	2.41	

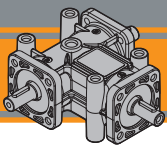

# ZP Rinvii angolari Right-angle bevel gearboxes

Dimensioni

Dimensions

## ZP 1 ... 4P ...

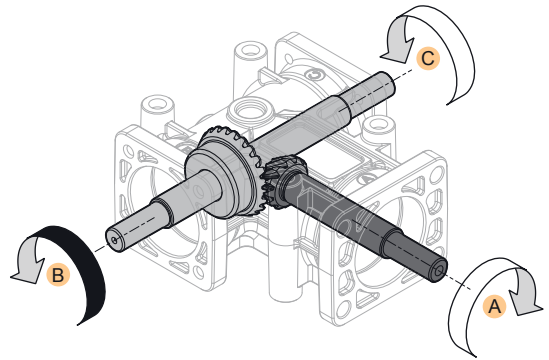
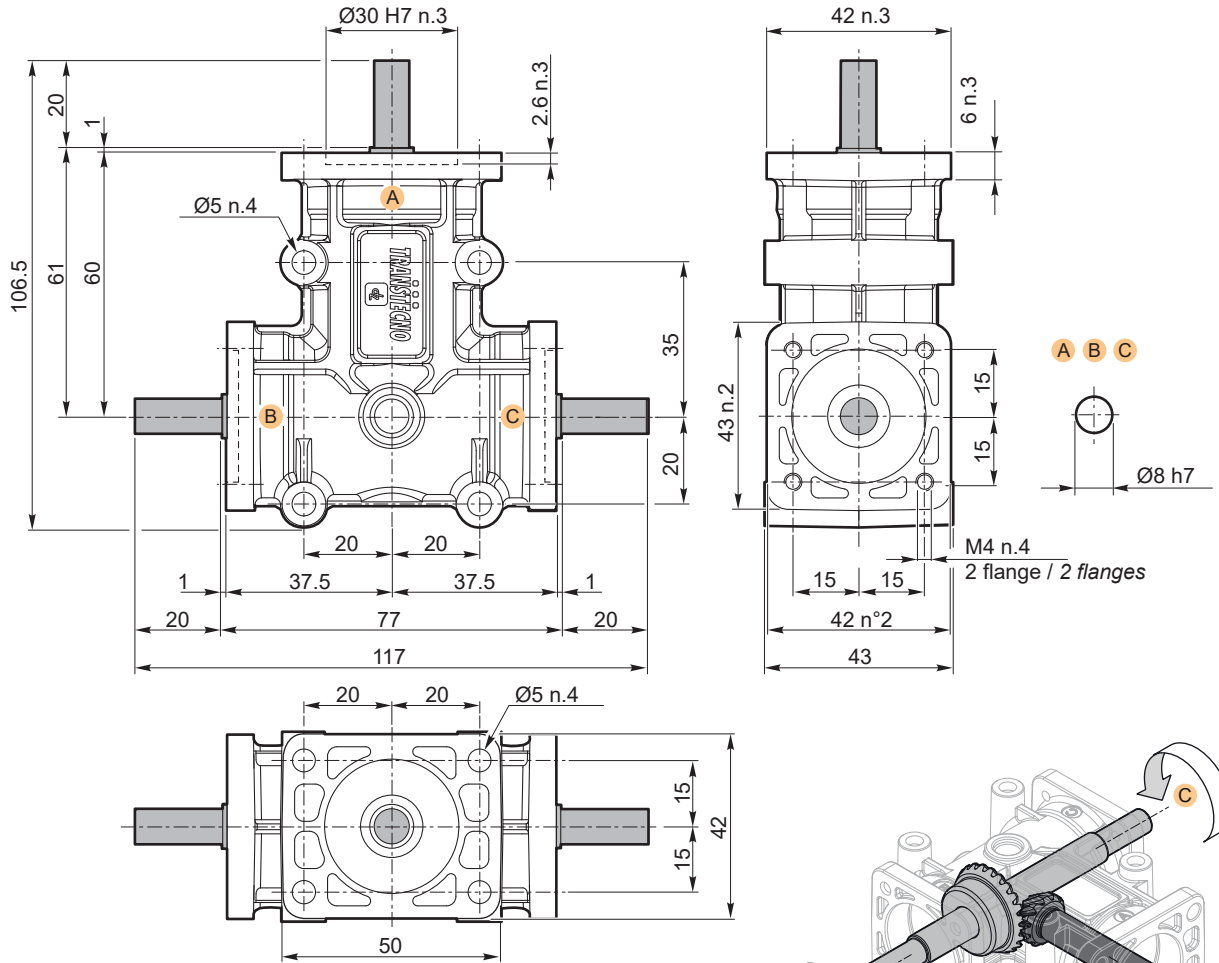

i	Code	Kg
1	ZP 11 4P ABC	0.6
2	ZP 13 4P ABC	

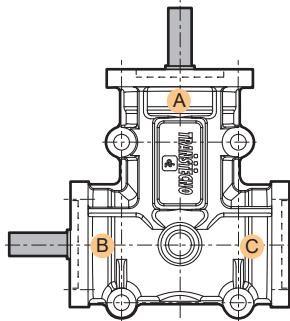

i	Code	Kg
1	ZP 10 S 4P AB	0.6
2	ZP 12 S 4P AB	

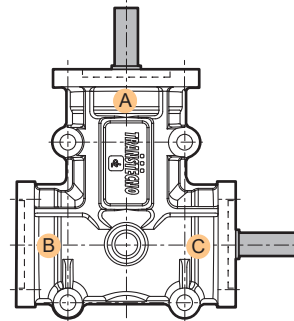

i	Code	Kg
1	ZP 10 FS 4P AC	0.6
2	ZP 12 FS 4P AC	

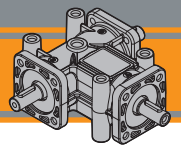

Dimensioni

Dimensions

**ZP 2... 4P ...**

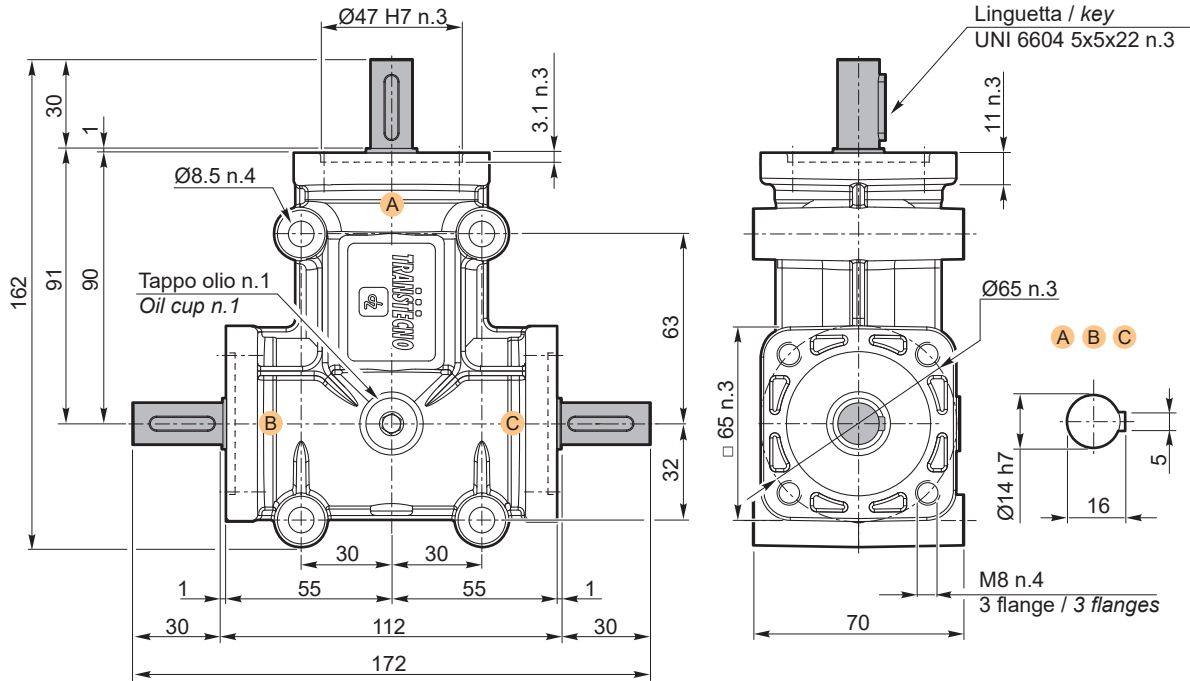

ZP

i	Code	Kg
1	ZP 21 4P ABC	2.0
2	ZP 23 4P ABC	
3	ZP 25 4P ABC	

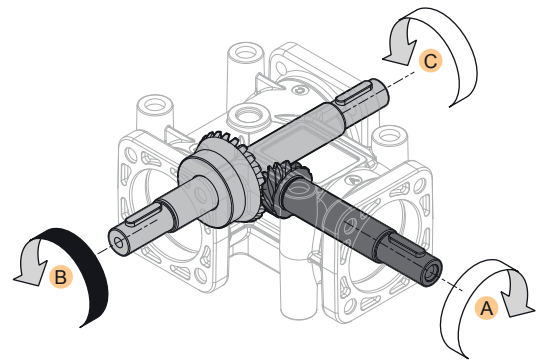

Le sedi linguetta negli alberi cavi come negli alberi maschi possono assumere qualsiasi posizione angolare.

The keyway in hollow shafts as in solid shafts can assume any angular position.

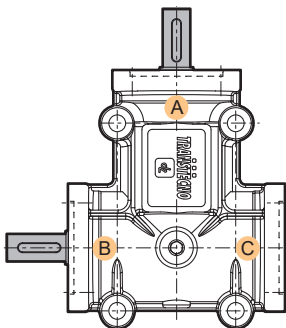

i	Code	Kg
1	ZP 20 S 4P AB	2.0
2	ZP 22 S 4P AB	
3	ZP 24 S 4P AB	

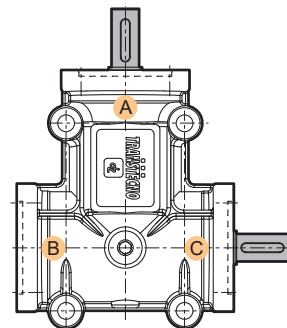

i	Code	Kg
1	ZP 20 FS 4P AC	2.0
2	ZP 22 FS 4P AC	
3	ZP 24 FS 4P AC	

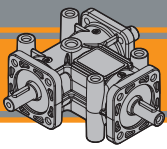



# ZP Rinvii angolari Right-angle bevel gearboxes

Dimensioni

Dimensions

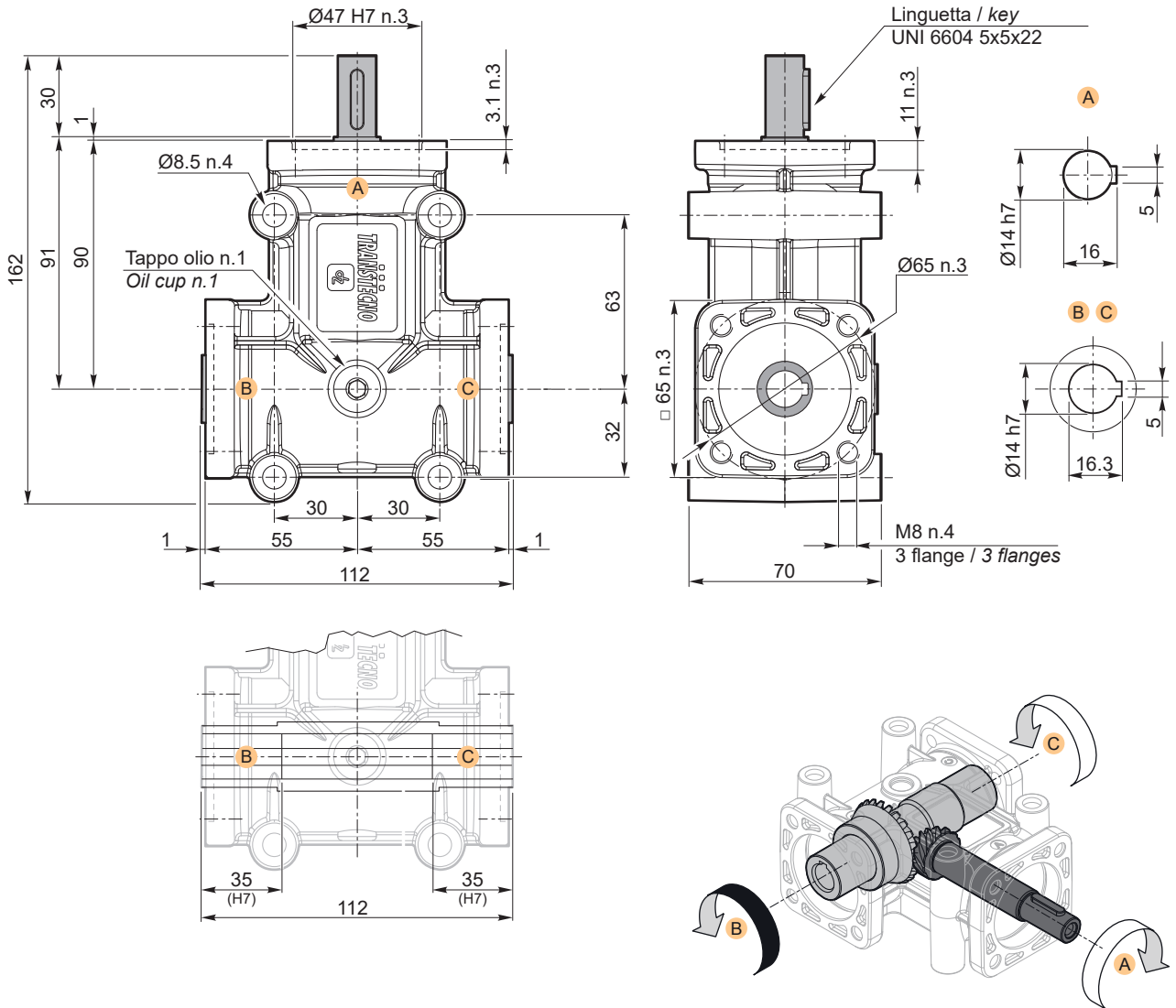
## ZP 21... 4P 3V



i	Code	 Kg
1	ZP 211 4P 3V	2.0
2	ZP 213 4P 3V	
3	ZP 215 4P 3V	

Le sedi linguetta negli alberi cavi come negli alberi maschi possono assumere qualsiasi posizione angolare.

The keyway in hollow shafts as in solid shafts can assume any angular position.



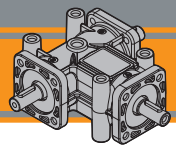

Dimensioni

Dimensions

ZP 2 ... 4P ...

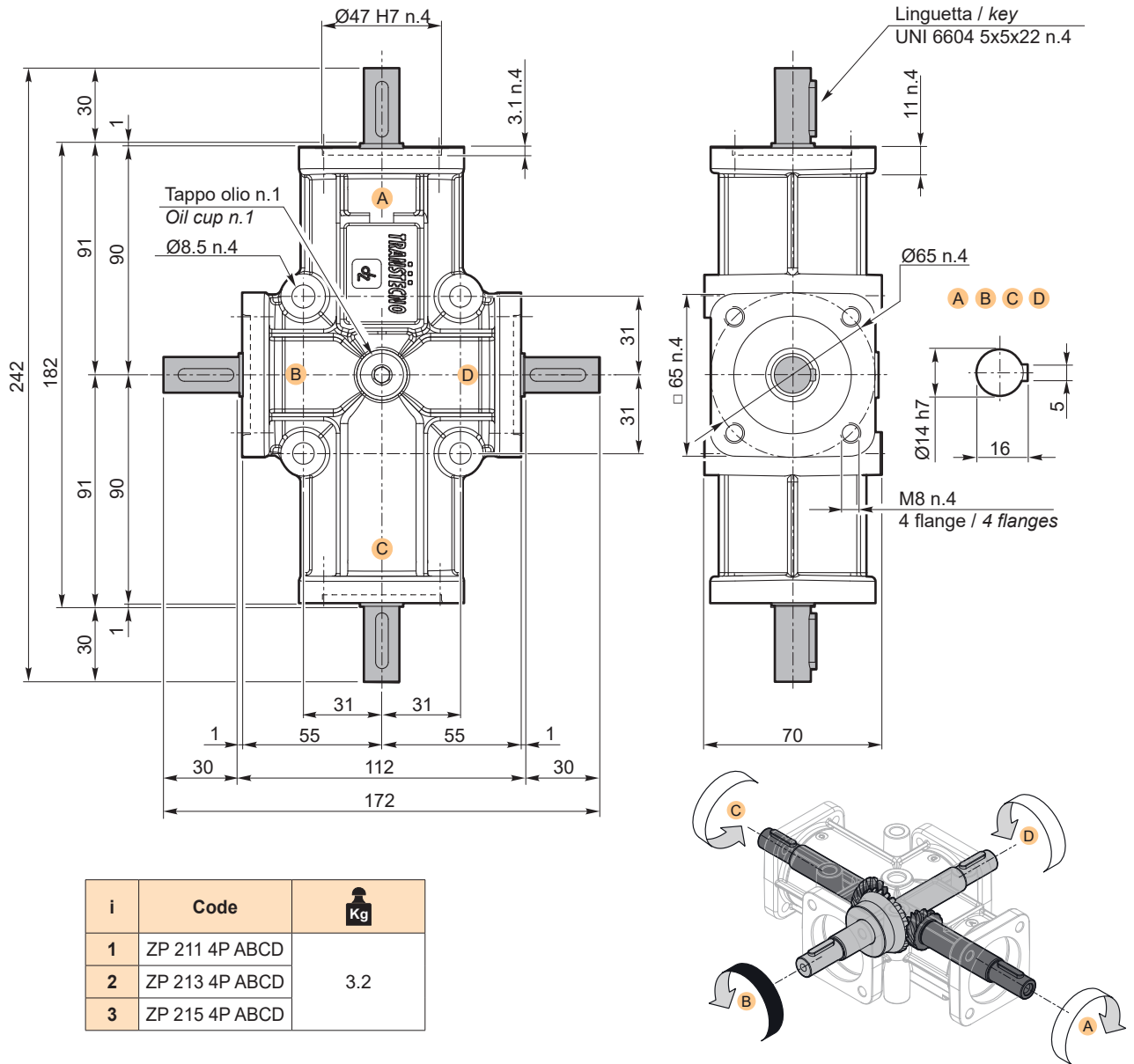

ZP

Le sedi linguetta negli alberi cavi come negli alberi maschi possono assumere qualsiasi posizione angolare.

The keyway in hollow shafts as in solid shafts can assume any angular position.

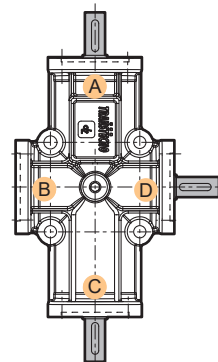
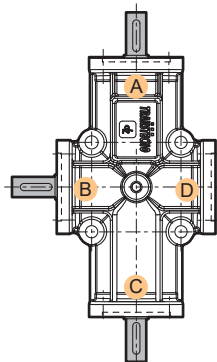

i	Code	Kg
1	ZP 220 S 4P ABC	3.2
2	ZP 222 S 4P ABC	
3	ZP 224 S 4P ABC	

i	Code	Kg
1	ZP 220 FS 4P ACD	3.2
2	ZP 222 FS 4P ACD	
3	ZP 224 FS 4P ACD	

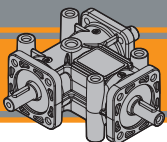

## ZP 21 4P 4V

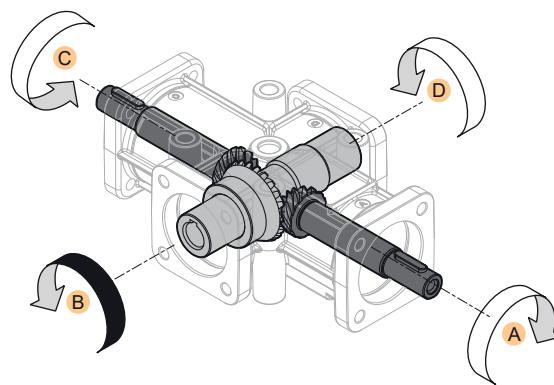
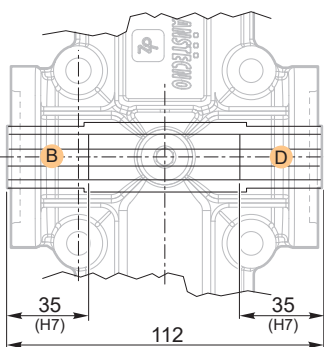
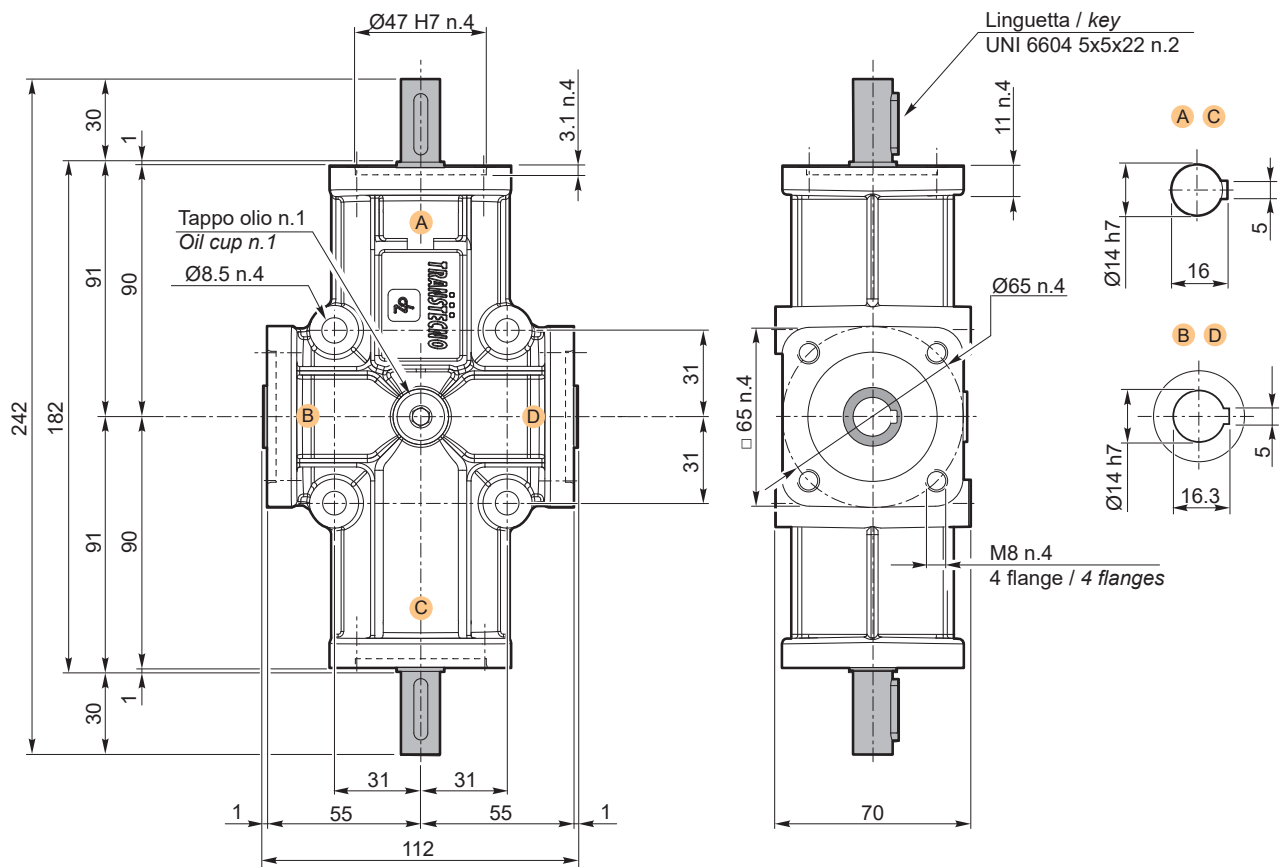

i	Code	Kg
1	ZP 211 4P 4V	3.0
2	ZP 213 4P 4V	
3	ZP 215 4P 4V	

Le sedi linguetta negli alberi cavi come negli alberi maschi possono assumere qualsiasi posizione angolare.

The keyway in hollow shafts as in solid shafts can assume any angular position.

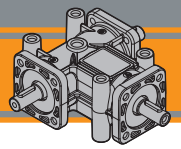

Dimensioni

Dimensions

ZP 31 4P 3V

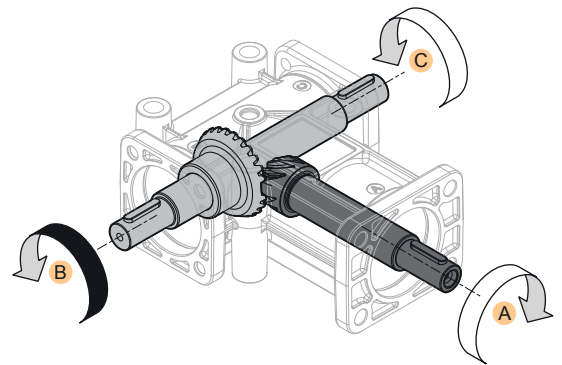
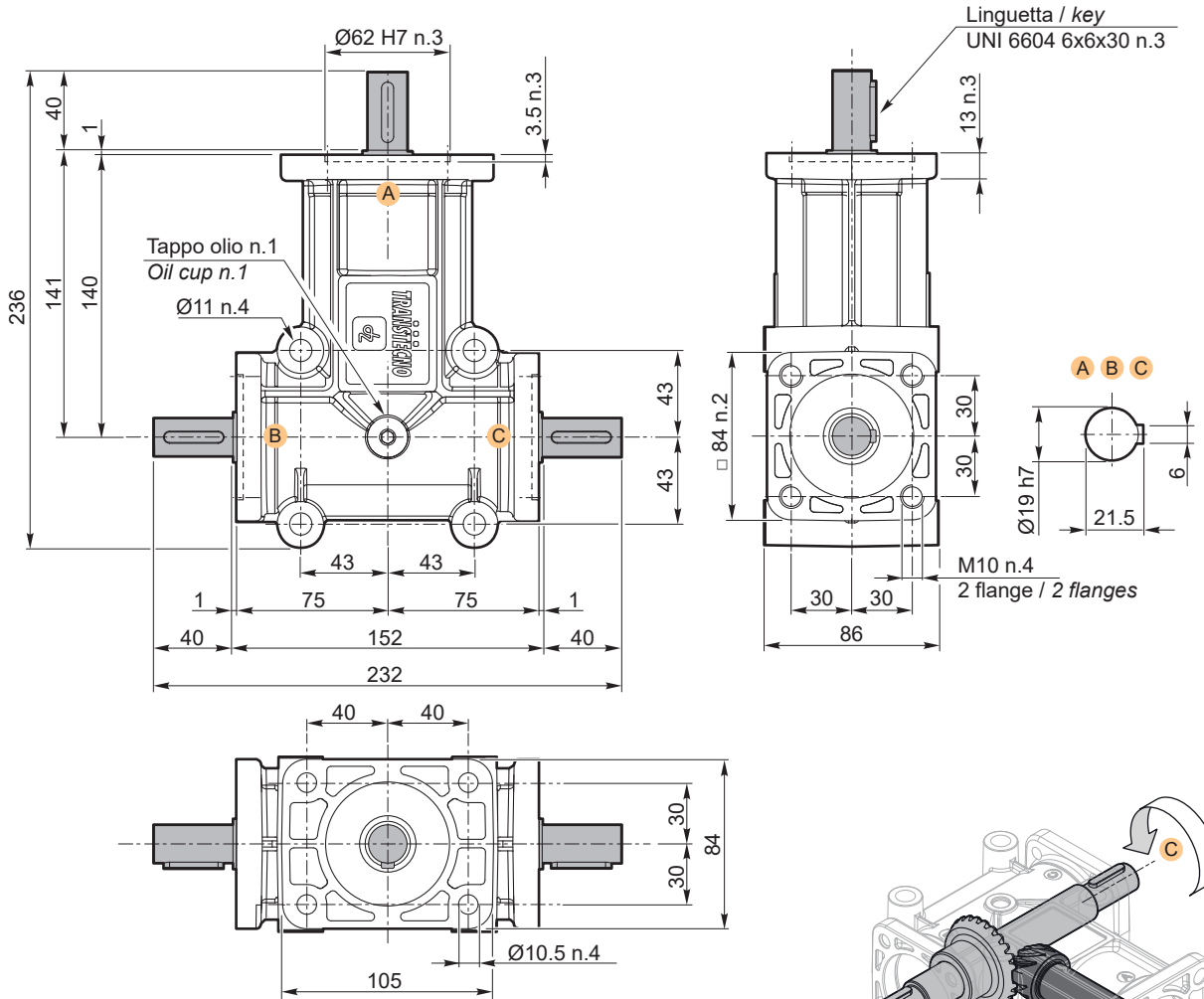

i	Code	Kg
1	ZP 31 4P ABC	4.5
2	ZP 33 4P ABC	
3	ZP 35 4P ABC	

Le sedi linguetta negli alberi cavi come negli alberi maschi possono assumere qualsiasi posizione angolare.

The keyway in hollow shafts as in solid shafts can assume any angular position.

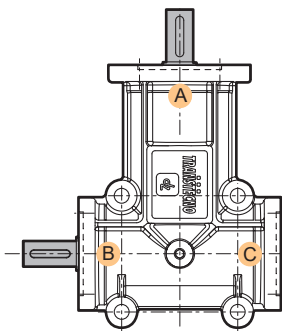

i	Code	Kg
1	ZP 30 S 4P AB	4.5
2	ZP 32 S 4P AB	
3	ZP 34 S 4P AB	

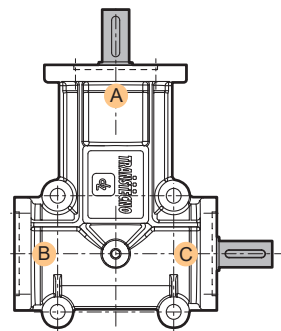

i	Code	Kg
1	ZP 30 FS 4P AC	4.5
2	ZP 32 FS 4P AC	
3	ZP 34 FS 4P AC	

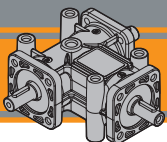



# ZP Rinvii angolari Right-angle bevel gearboxes

Dimensioni

Dimensions

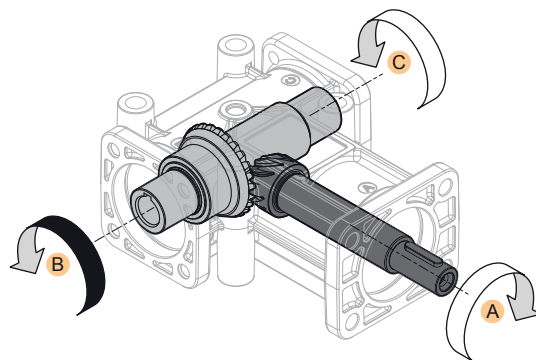
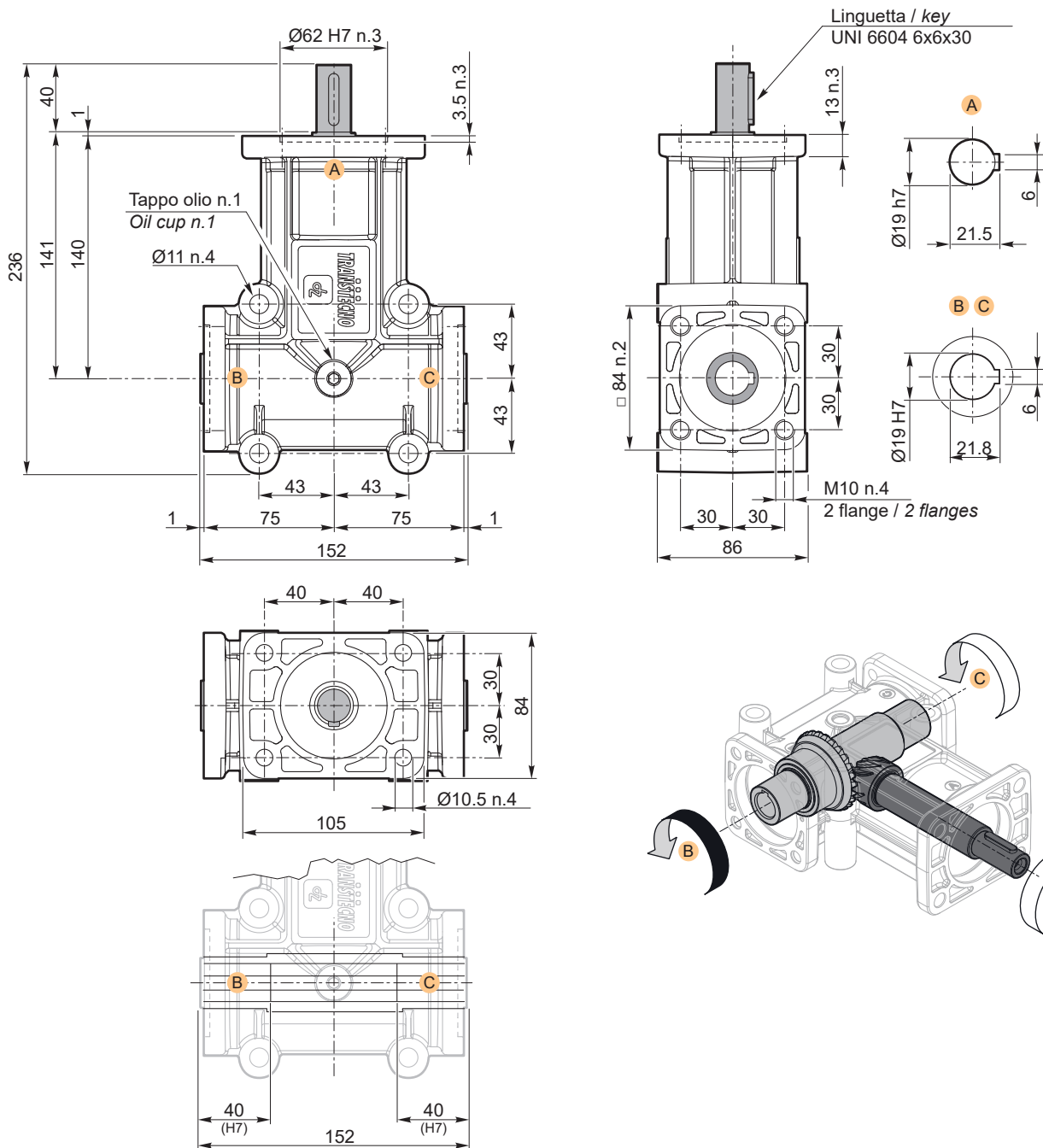
## ZP 3 ... 4P ...



i	Code	 Kg
1	ZP 311 4P 3V	4.5
2	ZP 313 4P 3V	
3	ZP 315 4P 3V	

Le sedi linguetta negli alberi cavi come negli alberi maschi possono assumere qualsiasi posizione angolare.

The keyway in hollow shafts as in solid shafts can assume any angular position.

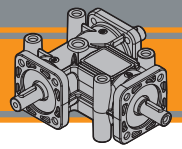

### Dimensioni

### Dimensions

## ZP 4... 4P ...

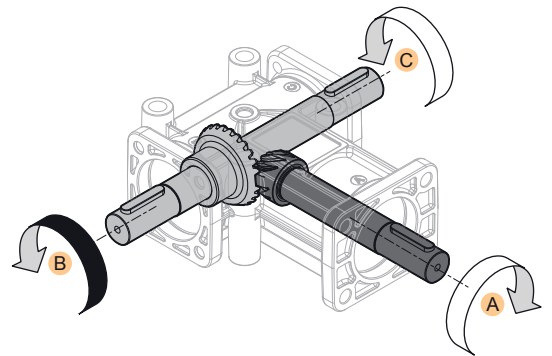
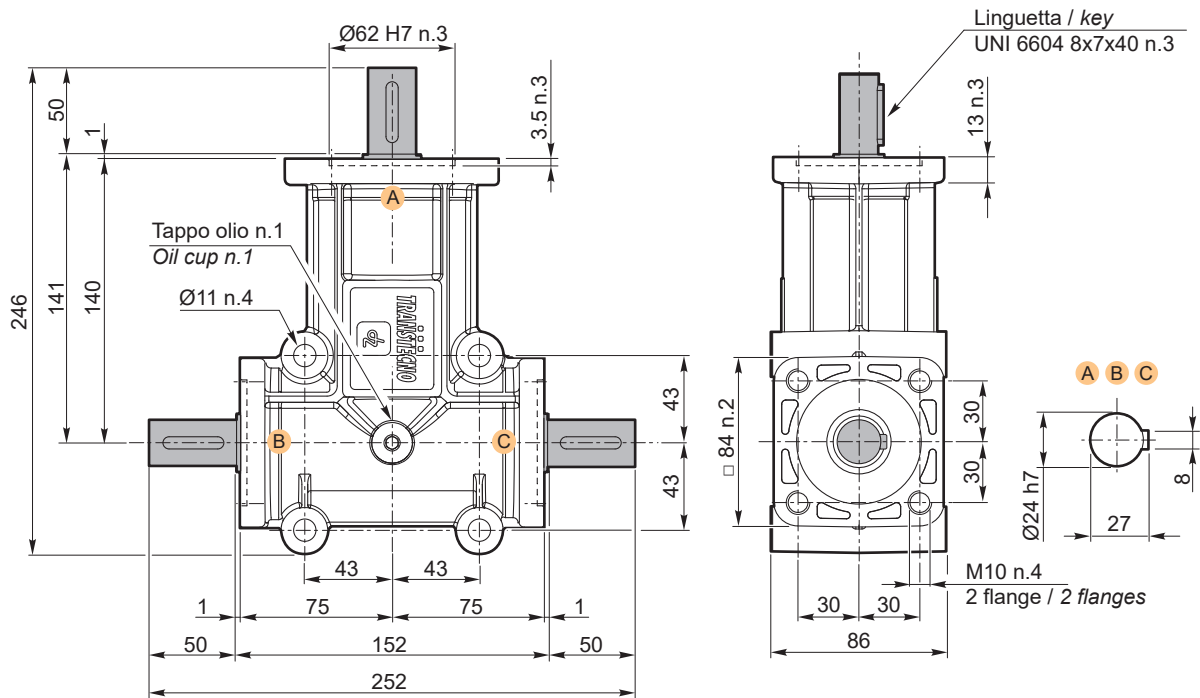

i	Code	Kg
1	ZP 41 4P ABC	4.5
2	ZP 43 4P ABC	
3	ZP 45 4P ABC	

Le sedi linguetta negli alberi cavi come negli alberi maschi possono assumere qualsiasi posizione angolare.

The keyway in hollow shafts as in solid shafts can assume any angular position.



i	Code	Kg
1	ZP 40 S 4P AB	4.5
2	ZP 42 S 4P AB	
3	ZP 44 S 4P AB	

i	Code	Kg
1	ZP 40 FS 4P AC	4.5
2	ZP 42 FS 4P AC	
3	ZP 44 FS 4P AC	

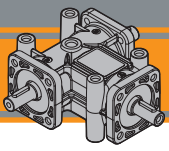

**ZP**

Rinvii angolari  
Right-angle bevel gearboxes

# Note/Notes



Rinvii angolari  
**Right-angle bevel gearboxes**







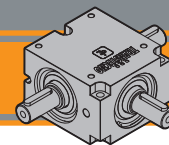

<b>Indice</b>	<b>Index</b>	Pag. Page
Caratteristiche tecniche	<i>Technical features</i>	<b>D2</b>
Designazione	<i>Classification</i>	<b>D3</b>
Versione	<i>Version</i>	<b>D3</b>
Sensi di rotazione	<i>Direction of rotation</i>	<b>D4</b>
Simbologia	<i>Symbols</i>	<b>D4</b>
Lubrificazione	<i>Lubrication</i>	<b>D5</b>
Carichi radiali e assiali	<i>Radial and axial loads</i>	<b>D5</b>
Dati tecnici	<i>Technical data</i>	<b>D5</b>
Dimensioni	<i>Dimensions</i>	<b>D6</b>

Questa sezione annulla e sostituisce ogni precedente edizione o revisione. Qualora questa sezione non Vi sia giunta in distribuzione controllata, l'aggiornamento dei dati ivi contenuto non è assicurato. **In tal caso la versione più aggiornata è disponibile sul nostro sito internet [www.transtecno.com](http://www.transtecno.com)**

*This section replaces any previous edition and revision. If you obtained this catalogue other than through controlled distribution channels, the most up to date content is not guaranteed. In this case the latest version is available on our web site [www.transtecno.com](http://www.transtecno.com)*

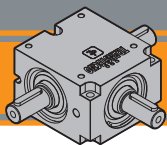

# BB Rinvii angolari Right-angle bevel gearboxes

## Caratteristiche tecniche

I rinvii angolari serie BB sono stati progettati per applicazioni industriali dove occorre trasmettere un moto rotatorio tra alberi disposti perpendicolarmente tra loro.

Sono disponibili:

- 2 grandezze: BB50 e BB90
- 5 rapporti: 1/1, 1/1.5, 1/2, 1/3 e 1/4 per BB50; 1/1 per BB90
- 2 o 1 prese di moto in uscita;

Caratteristiche comuni a tutta la serie sono:

- Carter monoblocco in lega di alluminio
- Coppia Conica Spiroidale GLEASON in acciaio al Nickel Cromo con trattamento di Cementazione - Tempra
- Alberi cavi in acciaio al carbonio e alberi maschi con trattamento di cementazione e tempra. Le sedi linguetta possono assumere qualsiasi posizione angolare
- Cuscinetti radiali a sfere
- Anelli nilos su BB50
- Anelli di tenuta tipo A in NBR su BB90
- Lubrificazione con grasso minerale 2 EP permanente per la grandezza BB50
- Lubrificazione con grasso minerale 00 EP permanente per la grandezza BB90

## Technical features

BB-series right-angle bevel gearboxes are designed for industrial applications where rotary motion must be transmitted between perpendicularly arranged shafts.

Those available:

- 2 sizes: BB50 and BB90
- 5 ratios: 1/1, 1/1.5, 1/2, 1/3 and 1/4 for BB50; 1/1 for BB90
- 2 or 1 output power take-off;

Common features throughout the series are:

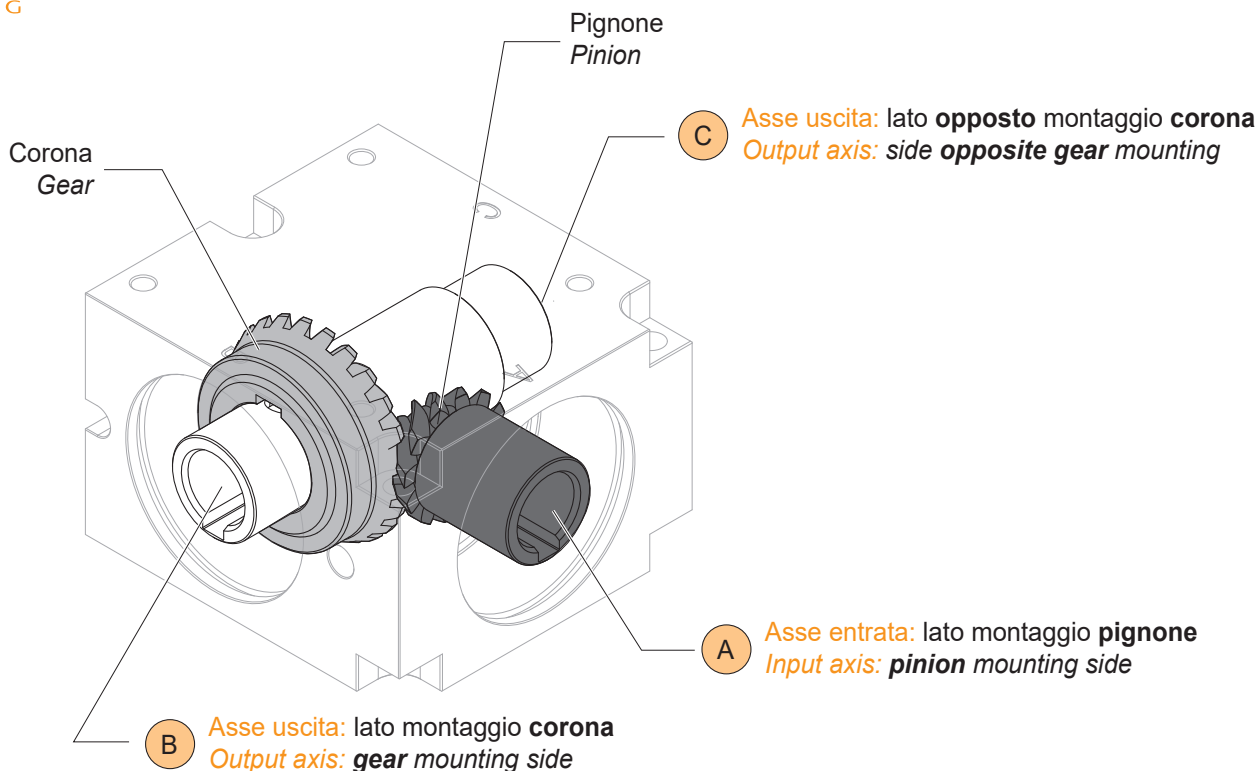

- One-piece aluminium alloy casing
- GLEASON spiral bevel gear in Nickel Chrome steel with Case hardening treatment
- Carbon steel hollow shafts and solid shafts with case hardening treatment. The feather key seats can assume any angular position
- Radial ball bearings
- Nilos rings on BB50
- Sealing rings type A in NBR on BB90
- Lubrication with permanent 2 EP mineral grease for size BB50
- Lubrication with permanent 00 EP mineral grease for size BB90

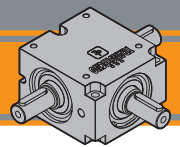



## Designazione

## Classification

RINVIO ANGOLARE / RIGHT-ANGLE BEVEL GEARBOX						
BB	IS	50	3	U	10	VS (*)
Tipo Type	Albero entrata (A) Input shaft (A)	Grandezza Size	Vie Shafts	Albero uscita (B e C) Output shaft (B and C)	Rapporto Ratio	Albero uscita (D) Output shaft (D)
<b>BB</b>	- Albero cavo Hollow shaft	<b>50</b>	<b>3</b>	<b>U</b>	<b>10</b> (i=1)	- (*)
	<b>IS</b> Albero maschio Shafts male	<b>90</b>	<b>4</b> (*)	<b>BC</b>	<b>15</b> (i=1.5) (*)	4 vie D albero cavo 4 shafts D hollow shaft
			*Solo gr.50 *Only size 50	<b>B</b>	<b>20</b> (i=2) (*)	<b>VS</b> (*)
				<b>C</b>	<b>30</b> (i=3) (*)	4 vie D albero maschio 4 shafts D male
					<b>40</b> (i=4) (*)	* Solo gr.50 * Only size 50

## Versione

## Version

### BB - 3 VIE / 3 SHAFTS

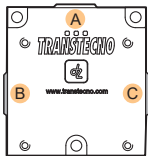

BB..3U..

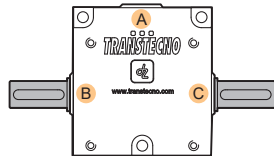

BB..3BC..

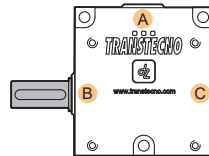

BB..3B..

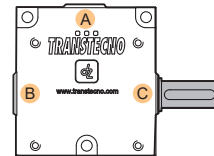

BB..3C..

### BBIS - 3 VIE / 3 SHAFTS

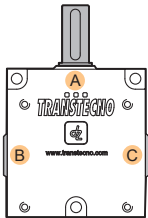

BBIS..3U..

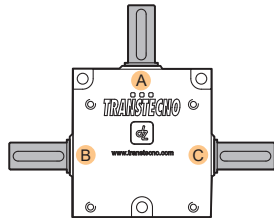

BBIS..3BC..

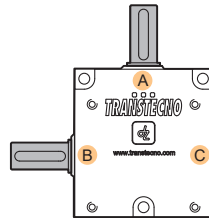

BBIS..3B..

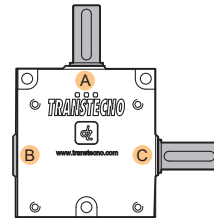

BBIS..3C..

### BB - 4 VIE / SHAFTS - Solo gr. 50 / Only size 50



BB..4U..

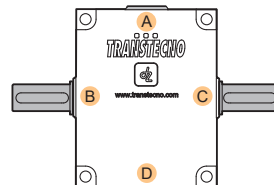

BB..4BC..

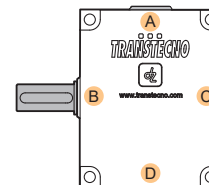

BB..4B..

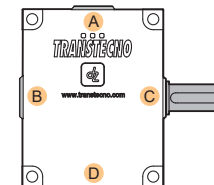

BB..4C..

### BBIS - 4 VIE / 4 SHAFTS - Solo gr. 50 / Only size 50

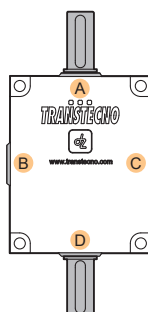

BBIS..4U..VS

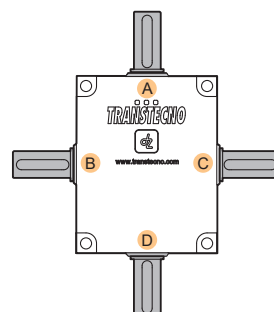

BBIS..4BC..VS

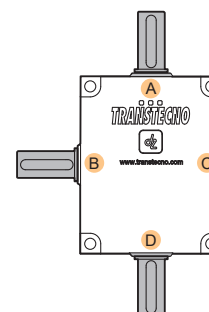

BBIS..4B..VS

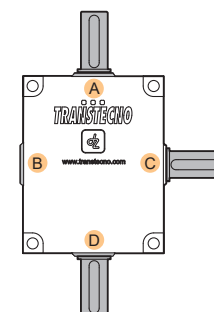

BBIS..4C..VS

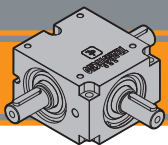

**3 VIE / 3 SHAFTS**

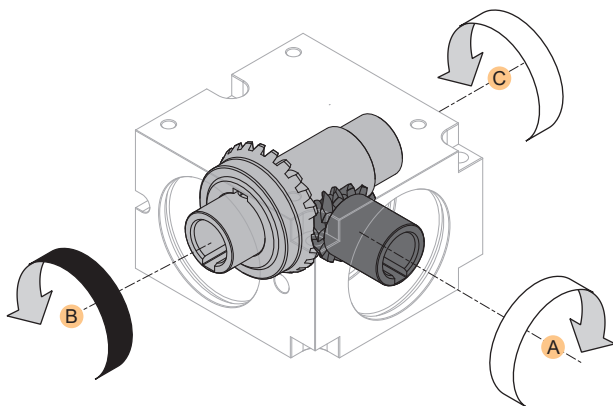

**4 VIE / 4 SHAFTS**

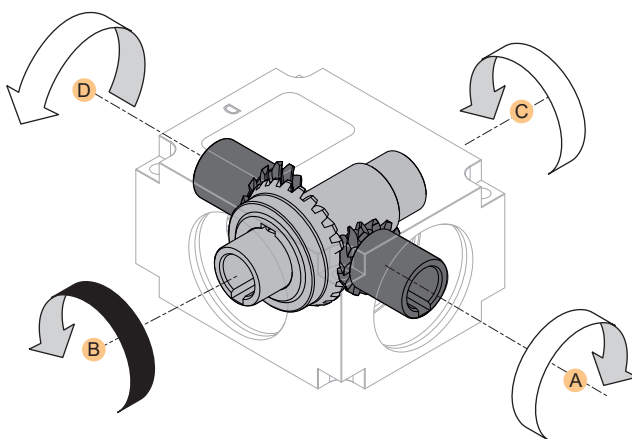

**Simbologia**

**Symbols**

$n_1$	[min <sup>-1</sup> ]	Velocità in ingresso / <i>Input speed</i>
$n_2$	[min <sup>-1</sup> ]	Velocità in uscita / <i>Output speed</i>
$i$		Rapporto di riduzione / <i>Ratio</i>
$P_1$	[kW]	Potenza in entrata / <i>Input power</i>
$M_2$	[Nm]	Coppia nominale in uscita in funzione di $P_1$ / <i>Output torque referred to <math>P_1</math></i>
$Pn_1$	[kW]	Potenza nominale in entrata / <i>Nominal input power</i>
$Mn_2$	[Nm]	Coppia nominale in uscita in funzione di $Pn_1$ / <i>Nominal output torque referred to <math>Pn_1</math></i>
$sf$		Fattore di servizio / <i>Service factor</i>
$R_1$	[N]	Carico radiale ammissibile in entrata / <i>Permitted input radial load</i>
$A_1$	[N]	Carico assiale ammissibile in entrata / <i>Permitted input axial load</i>
$R_2$	[N]	Carico radiale ammissibile in uscita / <i>Permitted output radial load</i>
$A_2$	[N]	Carico assiale ammissibile in uscita / <i>Permitted output axial load</i>
	[kg]	Peso del solo riduttore / <i>Weight of the gearbox only</i>

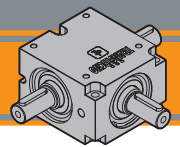

### Lubrificazione

I rinvii angolari serie BB, sono forniti completi di lubrificante minerale 2 EP.

Possono essere installati in qualunque posizione di montaggio.

### Lubrication

BB-series right-angle bevel gearboxes are supplied complete with 2 EP mineral lubricant.

They can be installed in any mounting position.

### Carichi radiali e assiali

Contattare il servizio tecnico.

### Radial and axial loads

Contact technical service.

### Dati tecnici

### Technical data

	i	n <sub>1</sub> [min <sup>-1</sup> ]	n <sub>2</sub> [min <sup>-1</sup> ]	M <sub>n2</sub> [Nm]	P <sub>n1</sub> [kW]	n <sub>1</sub> [min <sup>-1</sup> ]	n <sub>2</sub> [min <sup>-1</sup> ]	M <sub>n2</sub> [Nm]	P <sub>n1</sub> [kW]	n <sub>1</sub> [min <sup>-1</sup> ]	n <sub>2</sub> [min <sup>-1</sup> ]	M <sub>n2</sub> [Nm]	P <sub>n1</sub> [kW]	n <sub>1</sub> [min <sup>-1</sup> ]	n <sub>2</sub> [min <sup>-1</sup> ]	M <sub>n2</sub> [Nm]	P <sub>n1</sub> [kW]									
<b>BB 50</b>	1	50	50	25.4	0.13	100	100	21.3	0.21	250	250	17.0	0.43	500	500	11.8	0.59	750	750	9.5	0.72					
	1.5		33	31.0	0.10		67	25.5	0.17		167	18.0	0.30		333	13.5	0.45		500	11.0	0.55					
	2	50	25	20.0	0.05	100	50	19.5	0.10	250	125	18	0.23	500	250	14.5	0.36	750	375	11.7	0.44					
	3		17	10.0	0.02		33	9.9	0.03		83	9.8	0.08		167	9.6	0.16		250	9.4	0.24					
	4		13	6.7	0.01		25	6.6	0.02		63	6.5	0.04		125	6.4	0.08		188	6.3	0.12					
	1	1000	-				1500	-				2000	-				2500	-				3000	-			
	1.5		667	9.5	0.64	-		-	-	-	-		-	-	-	-		-	-	-	-		-	-	-	
	2		500	10.3	0.52	750		10	0.72	-	-		-	-	-	-		-	-	-	-		-	-	-	
	3		333	9.2	0.31	500		9.0	0.45	750	10		0.72	667	8.0	0.5		-	-	-	-		-	-	-	
	4	250	6.2	0.16	375	6.1	0.23	500	9.0	0.45	500	6.0	0.3	500	6.0	0.3	625	6.0	0.4	-	-					
<b>BB 90</b>	1	50	50	47.0	0.24	100	100	39.0	0.39	250	250	33.0	0.83	500	500	28.0	1.41	750	750	24.0	1.81					
	1	1000	-				1500	-				2000	-				2500	-				3000	-			

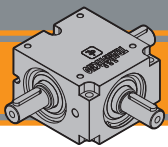

# BB Rinvii angolari Right-angle bevel gearboxes

Dimensioni

Dimensions

## BB 503 U...

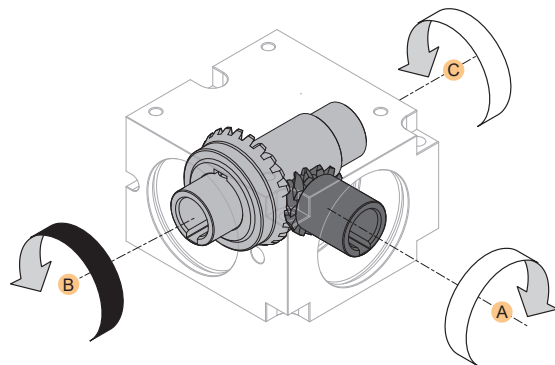
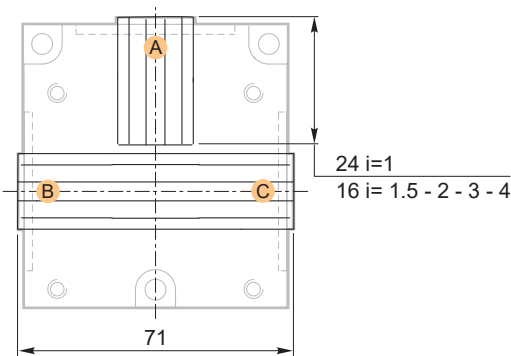
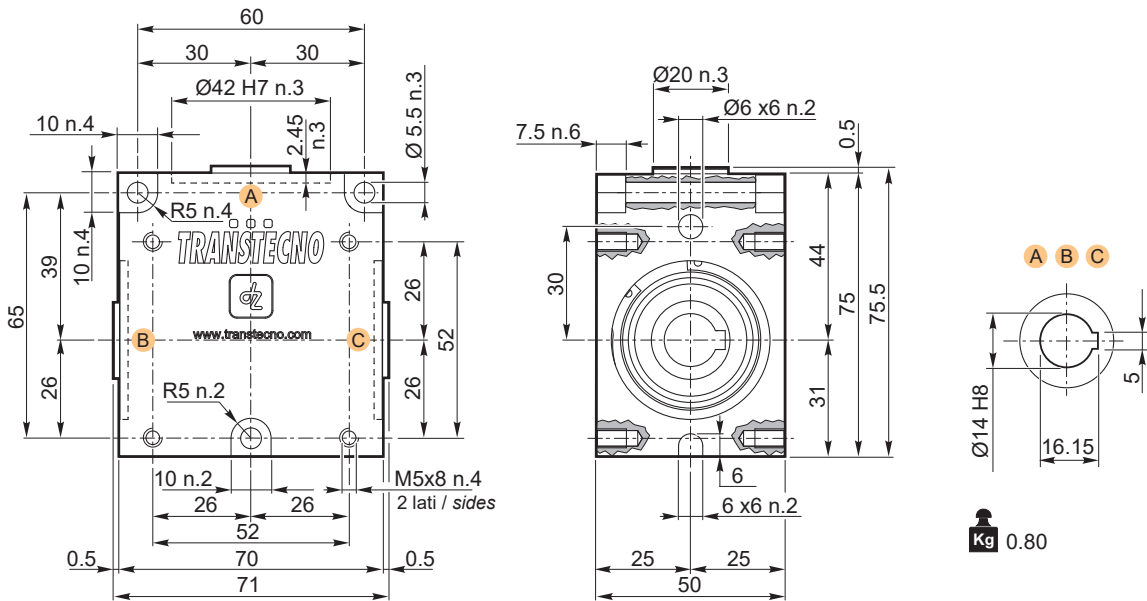

Le sedi linguetta negli alberi cavi come negli alberi maschi possono assumere qualsiasi posizione angolare.

The keyways in hollow shafts as in solid shafts can assume any angular position.

Versione

Version

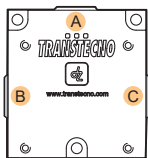

BB..3U..

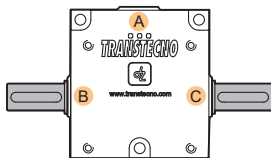

BB..3BC..

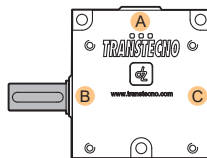

BB..3B..

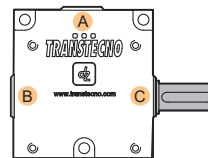

BB..3C..

i	Code
1	BB503U10 TTN
1.5	BB503U15 TTN
2	BB503U20 TTN
3	BB503U30 TTN
4	BB503U40 TTN

i	Code
1	BB503BC10 TTN
1.5	BB503BC15 TTN
2	BB503BC20 TTN
3	BB503BC30 TTN
4	BB503BC40 TTN

i	Code
1	BB503B10 TTN
1.5	BB503B15 TTN
2	BB503B20 TTN
3	BB503B30 TTN
4	BB503B40 TTN

i	Code
1	BB503C10 TTN
1.5	BB503C15 TTN
2	BB503C20 TTN
3	BB503C30 TTN
4	BB503C40 TTN

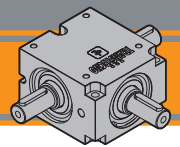

Dimensioni

Dimensions

BBIS 503 BC...

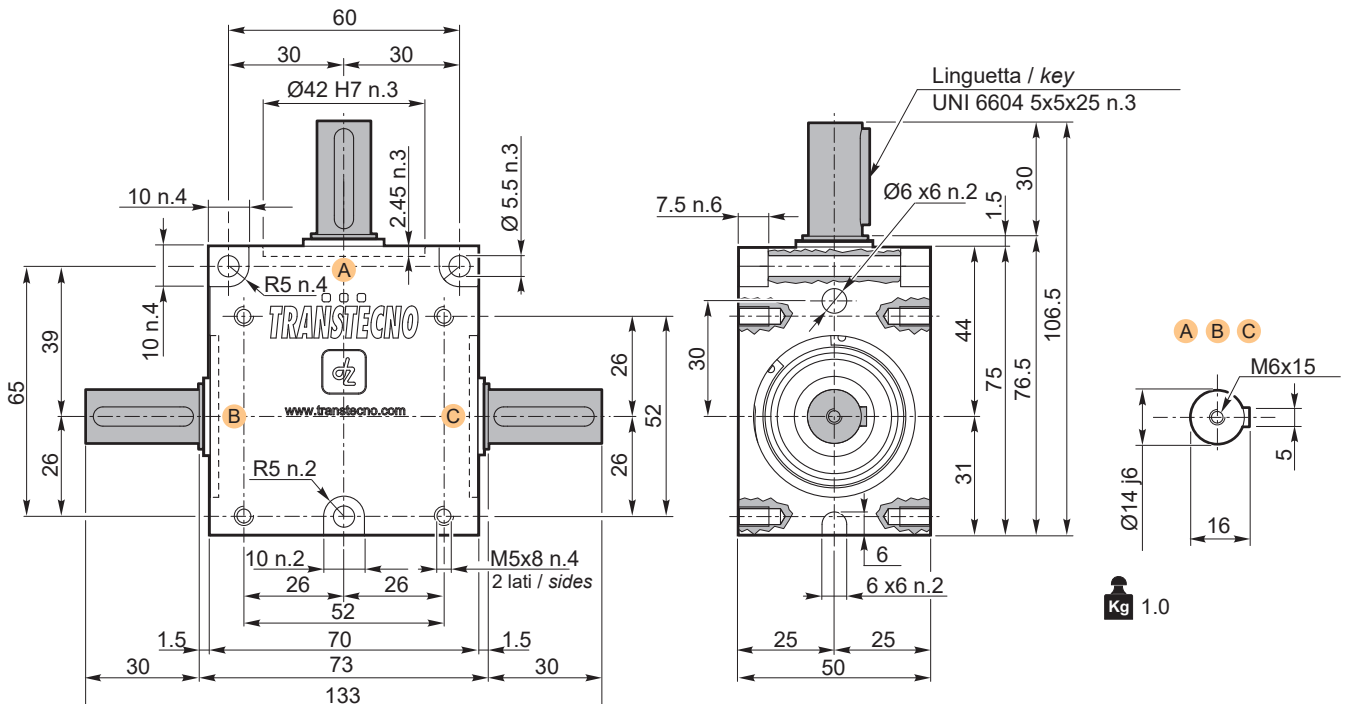

BB

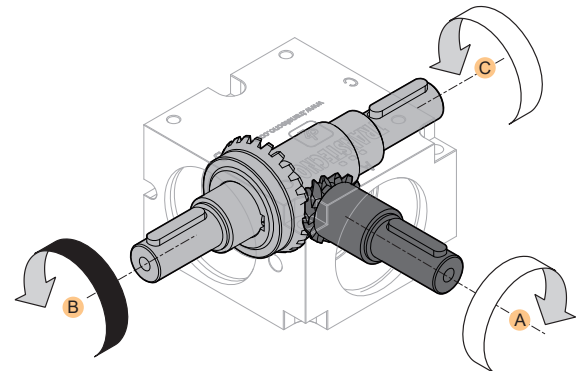

Le sedi linguetta negli alberi cavi come negli alberi maschi possono assumere qualsiasi posizione angolare.

The keyways in hollow shafts as in solid shafts can assume any angular position.

Versione

Version

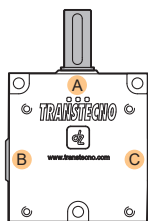

BBIS..3U..

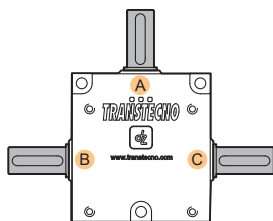

BBIS..3BC..

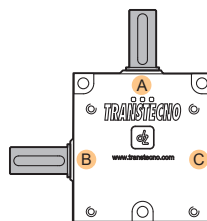

BBIS..3B..

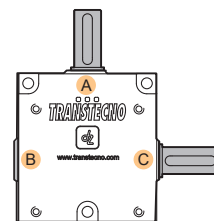

BBIS..3C..

i	Code
1	BBIS503U10 TTN
1.5	BBIS503U15 TTN
2	BBIS503U20 TTN
3	BBIS503U30 TTN
4	BBIS503U40 TTN

i	Code
1	BBIS503BC10 TTN
1.5	BBIS503BC15 TTN
2	BBIS503BC20 TTN
3	BBIS503BC30 TTN
4	BBIS503BC40 TTN

i	Code
1	BBIS503B10 TTN
1.5	BBIS503B15 TTN
2	BBIS503B20 TTN
3	BBIS503B30 TTN
4	BBIS503B40 TTN

i	Code
1	BBIS503C10 TTN
1.5	BBIS503C15 TTN
2	BBIS503C20 TTN
3	BBIS503C30 TTN
4	BBIS503C40 TTN

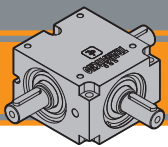

# BB Rinvii angolari Right-angle bevel gearboxes

Dimensioni

Dimensions

## BB 504 U...

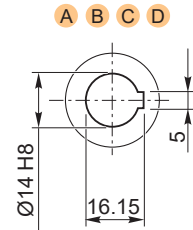
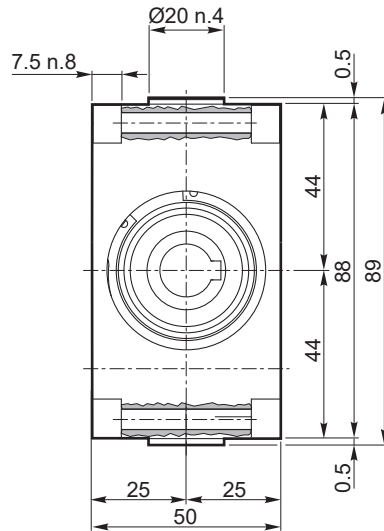
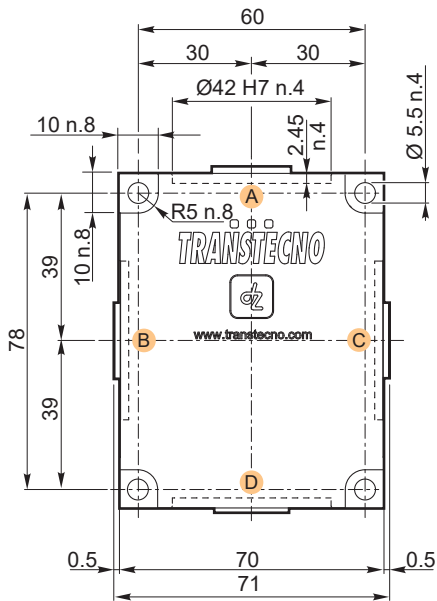

**Kg** 1.0

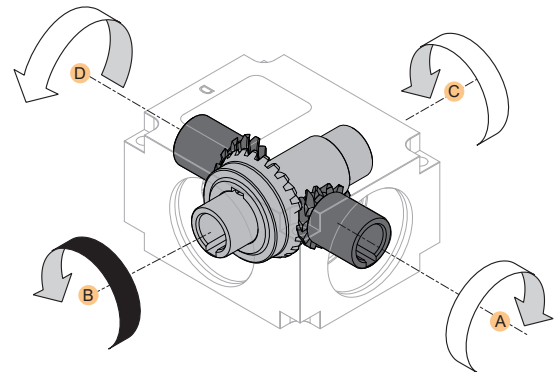
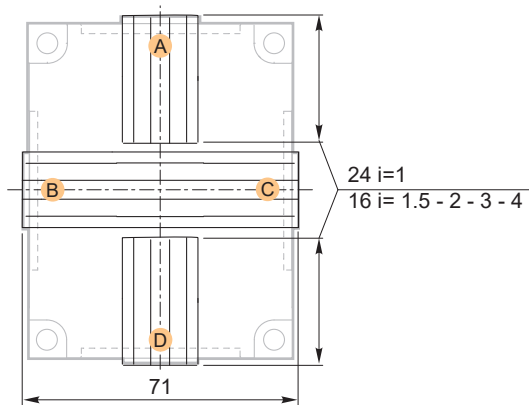

Le sedi linguetta negli alberi cavi come negli alberi maschi possono assumere qualsiasi posizione angolare.

The keyways in hollow shafts as in solid shafts can assume any angular position.

Versione

Version



BB..4U..

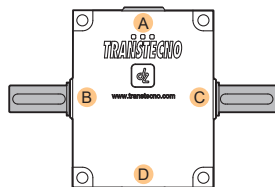

BB..4BC..

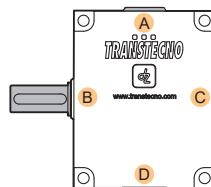

BB..4B..

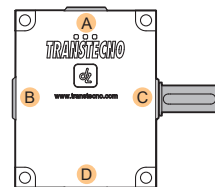

BB..4C..

i	Code
1	BB504U10 TTN
1.5	BB504U15 TTN
2	BB504U20 TTN
3	BB504U30 TTN
4	BB504U40 TTN

i	Code
1	BB504BC10 TTN
1.5	BB504BC15 TTN
2	BB504BC20 TTN
3	BB504BC30 TTN
4	BB504BC40 TTN

i	Code
1	BB504B10 TTN
1.5	BB504B15 TTN
2	BB504B20 TTN
3	BB504B30 TTN
4	BB504B40 TTN

i	Code
1	BB504C10 TTN
1.5	BB504C15 TTN
2	BB504C20 TTN
3	BB504C30 TTN
4	BB504C40 TTN



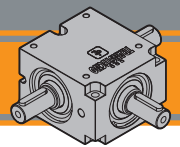

**Dimensioni**

**Dimensions**

**BBIS 504 BC...VS**

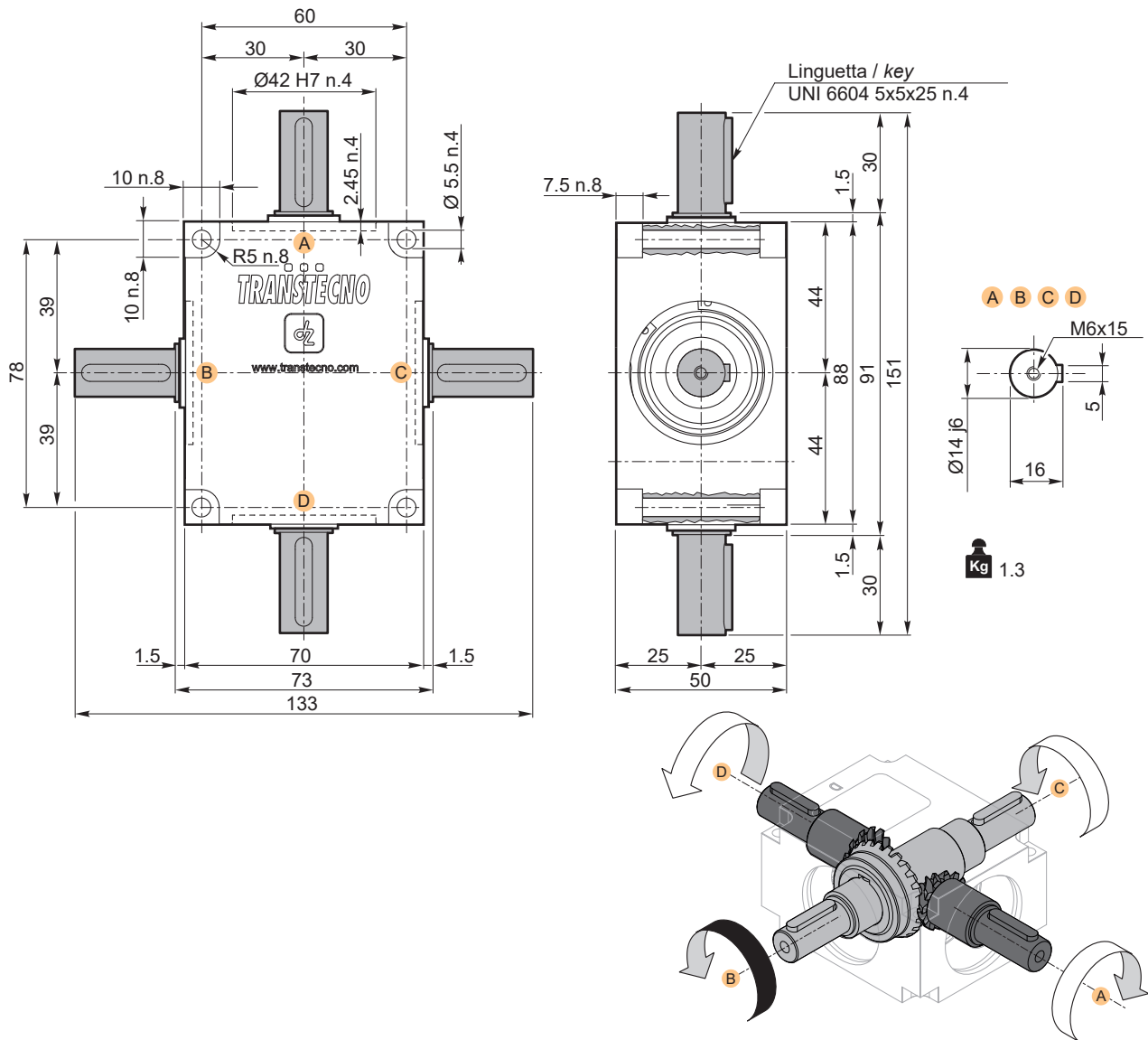

Le sedi linguetta negli alberi cavi come negli alberi maschi possono assumere qualsiasi posizione angolare.

The keyways in hollow shafts as in solid shafts can assume any angular position.

**Versione**

**Version**

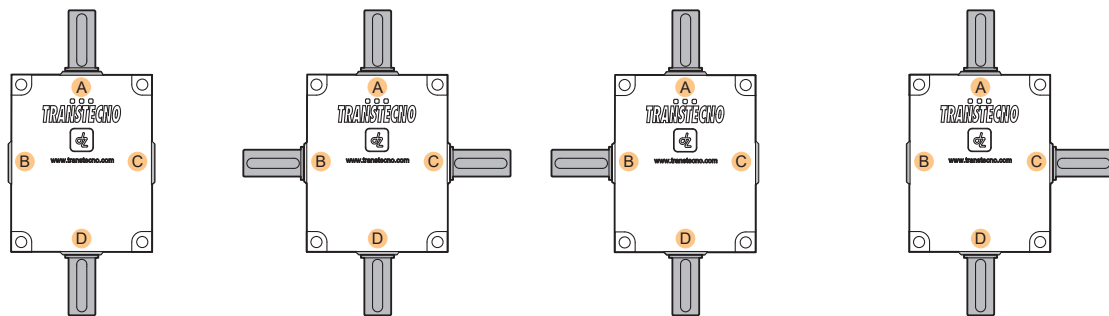

**BBIS..4U..VS**

i	Code
1	BBIS504U10VS TTN
1.5	BBIS504U15VS TTN
2	BBIS504U20VS TTN
3	BBIS504U30VS TTN
4	BBIS504U40VS TTN

**BBIS..4BC..VS**

i	Code
1	BBIS504BC10VS TTN
1.5	BBIS504BC15VS TTN
2	BBIS504BC20VS TTN
3	BBIS504BC30VS TTN
4	BBIS504BC40VS TTN

**BBIS..4B..VS**

i	Code
1	BBIS504B10VS TTN
1.5	BBIS504B15VS TTN
2	BBIS504B20VS TTN
3	BBIS504B30VS TTN
4	BBIS504B40VS TTN

**BBIS..4C..VS**

i	Code
1	BBIS504C10VS TTN
1.5	BBIS504C15VS TTN
2	BBIS504C20VS TTN
3	BBIS504C30VS TTN
4	BBIS504C40VS TTN

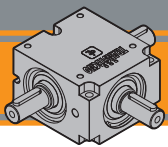

# BB Rinvii angolari Right-angle bevel gearboxes

Dimensioni

Dimensions

## BB 903 U...

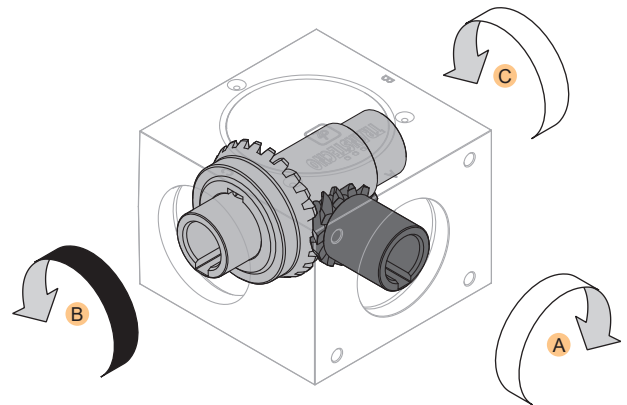
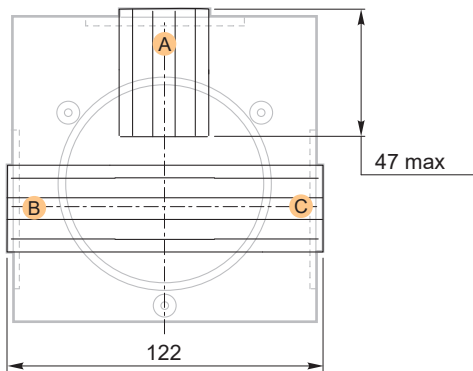
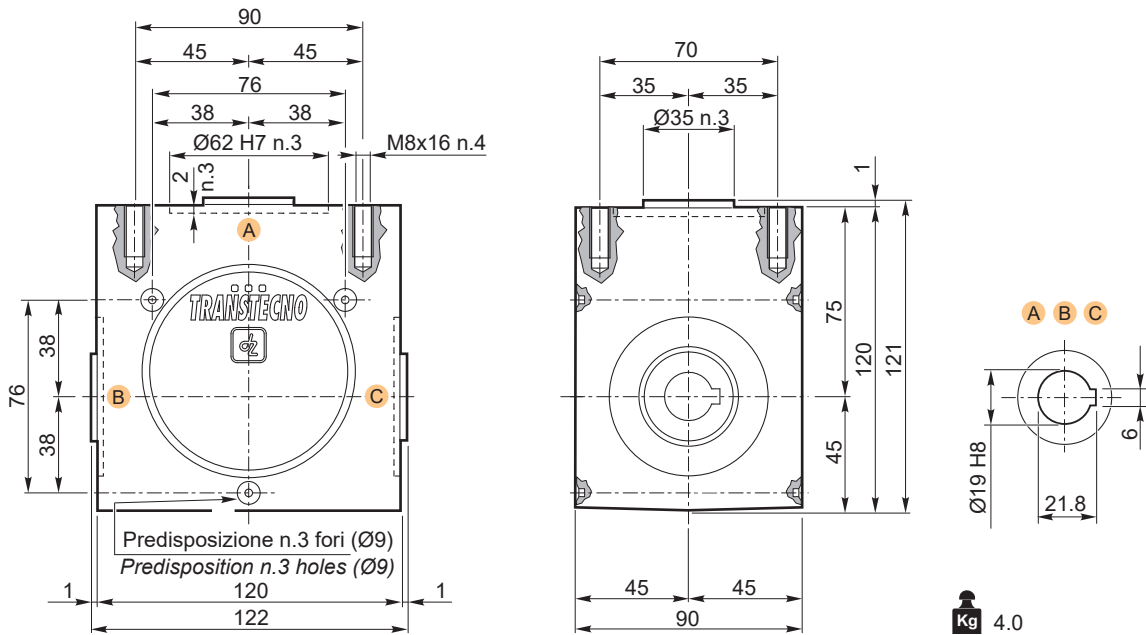

Le sedi linguetta negli alberi cavi come negli alberi maschi possono assumere qualsiasi posizione angolare.

The keyways in hollow shafts as in solid shafts can assume any angular position.

Versione

Version

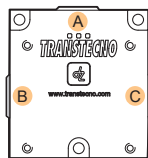

BB..3U..

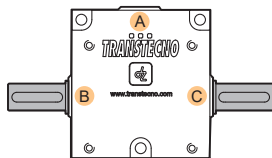

BB..3BC..

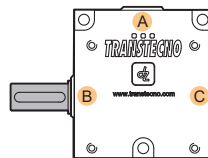

BB..3B..

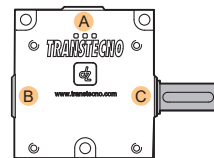

BB..3C..

i	Code
1	BB903U10 TTN

i	Code
1	BB903BC10 TTN

i	Code
1	BB903B10 TTN

i	Code
1	BB903C10 TTN

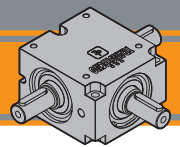

Dimensioni

Dimensions

BBIS 903 BC...

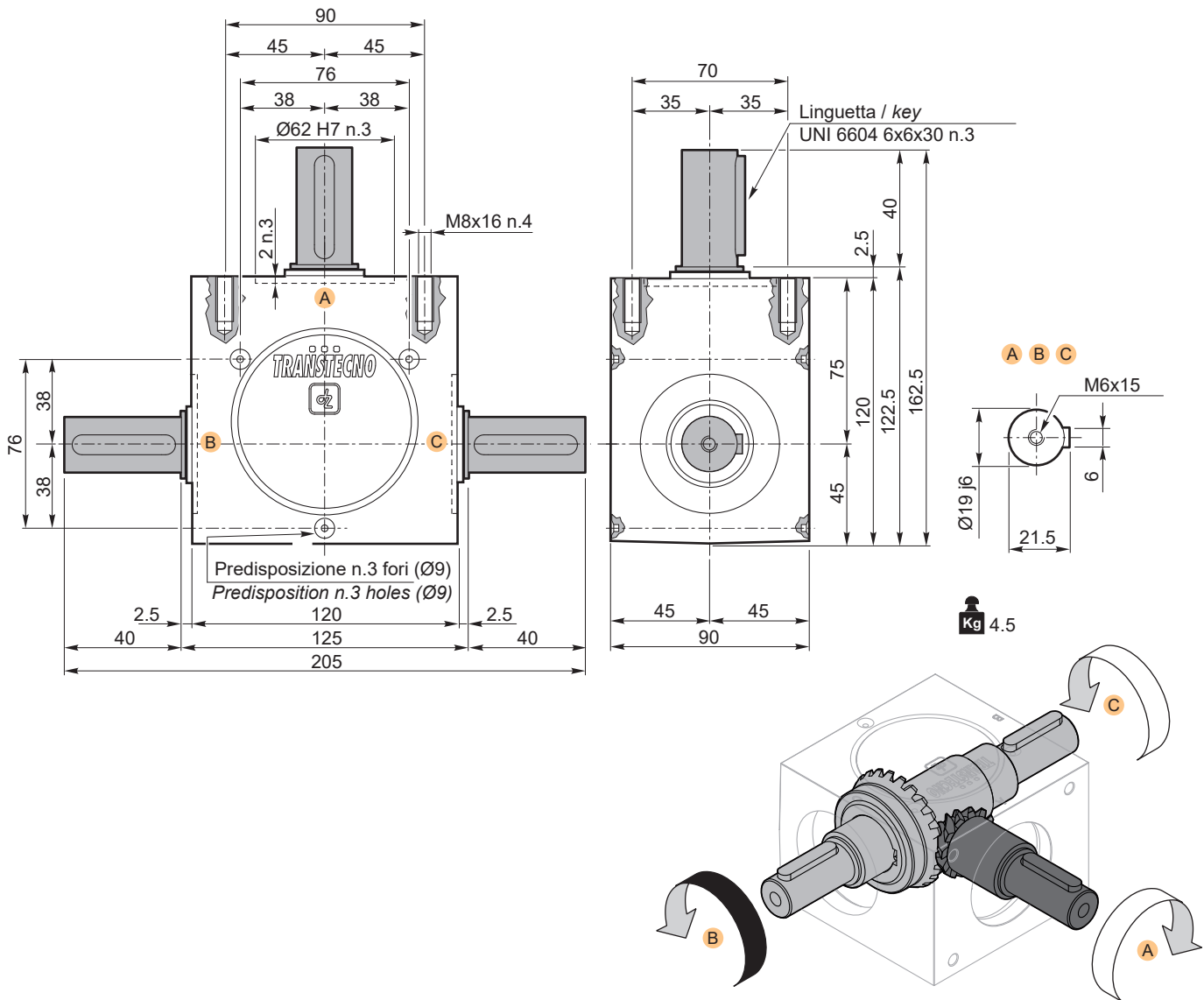

Le sedi linguetta negli alberi cavi come negli alberi maschi possono assumere qualsiasi posizione angolare.

The keyways in hollow shafts as in solid shafts can assume any angular position.

Versione

Version

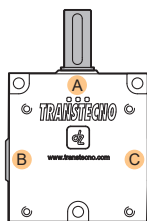

BBIS..3U..

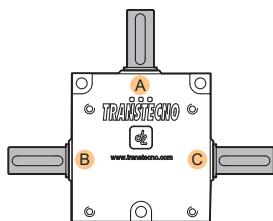

BBIS..3BC..

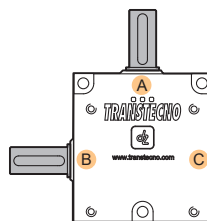

BBIS..3B..

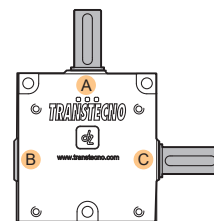

BBIS..3C..

i	Code
1	BBIS903U10 TTN

i	Code
1	BBIS903BC10 TTN

i	Code
1	BBIS903B10 TTN

i	Code
1	BBIS903C10 TTN

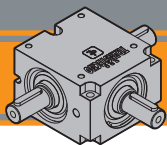

**BB**

Rinvii angolari

Right-angle bevel gearboxes

# Note/Notes



Rinvii angolari  
**Right-angle bevel gearboxes**





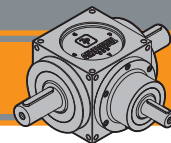

<b>Indice</b>	<b>Index</b>	Pag. Page
Caratteristiche tecniche	<i>Technical features</i>	<b>E2</b>
Designazione	<i>Classification</i>	<b>E3</b>
Sensi di rotazione	<i>Direction of rotation</i>	<b>E4</b>
Simbologia	<i>Symbols</i>	<b>E5</b>
Lubrificazione	<i>Lubrication</i>	<b>E5</b>
Carichi radiali e assiali	<i>Radial and axial loads</i>	<b>E6</b>
Dati tecnici	<i>Technical data</i>	<b>E16</b>
Forme costruttive	<i>Constructive forms</i>	<b>E18</b>
Dimensioni	<i>Dimensions</i>	<b>E26</b>

Questa sezione annulla e sostituisce ogni precedente edizione o revisione. Qualora questa sezione non Vi sia giunta in distribuzione controllata, l'aggiornamento dei dati ivi contenuto non è assicurato. **In tal caso la versione più aggiornata è disponibile sul nostro sito internet [www.transtecno.com](http://www.transtecno.com)**

*This section replaces any previous edition and revision. If you obtained this catalogue other than through controlled distribution channels, the most up to date content is not guaranteed. In this case the latest version is available on our web site [www.transtecno.com](http://www.transtecno.com)*

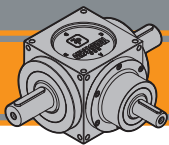

# QB Rinvii angolari Right-angle bevel gearboxes

## Caratteristiche tecniche

## Technical features

I rinvii angolari serie QB sono stati progettati per applicazioni industriali dove occorre trasmettere un moto rotatorio tra alberi disposti perpendicolarmente tra loro

QB-series right-angle bevel gearboxes are designed for industrial applications where rotary motion must be transmitted between perpendicularly arranged shafts

Sono disponibili:

Those available:

- 8 grandezze: 54 , 86 , 110 , 134 , 166 , 200 , 250 e 350
- 5 rapporti: 1/1 , 1/1.5 , 1/2 , 1/3 e 1/4;
- Da 1 fino a 5 presa moto uscita;

- 8 sizes: 54, 86, 110, 134, 166, 200, 250 and 350
- 5 ratios: 1/1, 1/1.5, 1/2, 1/3 and 1/4;
- From 1 to 5 output power take-off;

Caratteristiche comuni a tutta la serie sono:

Common features throughout the series are:

- Carter e torretta in lega di alluminio ricavati da trafilato o fusione (tranne QB 350 in ghisa) predisposta con 4 fori filettati per il fissaggio su ciascuna delle 6 facce
- Coppia Conica Spiroidale GLEASON in acciaio al Nichel Cromo con trattamento di Cementazione - Tempra
- Alberi in acciaio al carbonio disponibili in diverse tipologie costruttive: versione maschio con linguetta, versione cava con sede linguetta, versione cava con scanalato UNI 8953 e versione cava predisposta per calettatore. Le sedi linguetta negli alberi cavi come negli alberi maschi possono assumere qualsiasi posizione angolare
- Cuscinetti a rulli conici (tranne QB54 che prevede cuscinetti radiali a sfere)
- Anelli di Tenuta tipo A in NBR sugli alberi e O-ring in NBR a chiusura delle torrette
- Lubrificazione con olio sintetico ISO 150 ad esclusione della taglia QB54 prevista con grasso minerale 00 EP permanente

- Casing and bell housing in drawn or cast aluminium alloy (except for QB 350 in cast iron) fitted with 4 threaded holes for fixing on each of the 6 sides
- GLEASON spiral bevel gear in Nickel Chrome steel with Case hardening treatment
- Carbon steel shafts available in different constructive forms: solid version with key, hollow version with keyway, hollow version with UNI 8953 groove and hollow version prepared for shrink disc. The keyways in hollow shafts as in solid shafts can assume any angular position
- Tapered roller bearings (except QB54 which has radial ball bearings)
- NBR type A sealing rings on the shafts and NBR O-rings for closing the bell housings
- Lubrication with synthetic oil ISO 150 except QB54 size provided with permanent 00 EP mineral grease

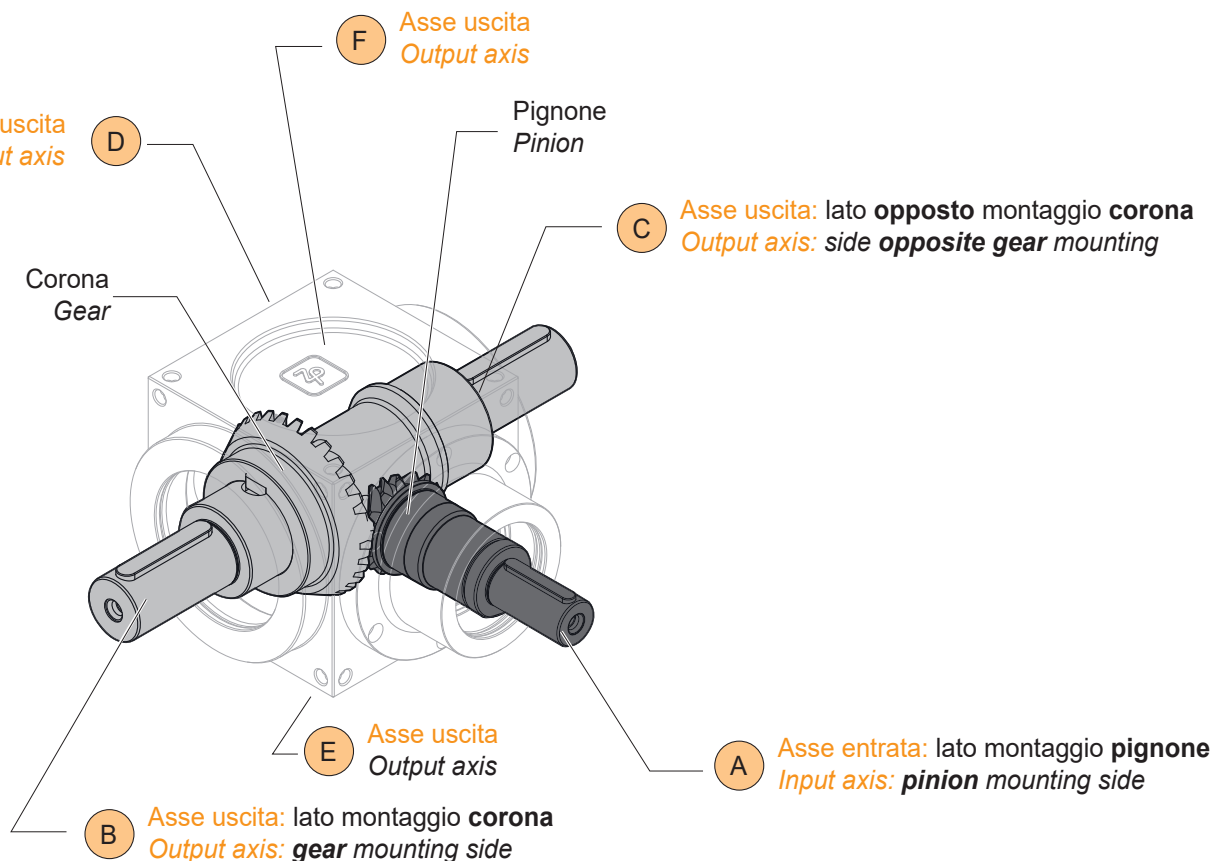



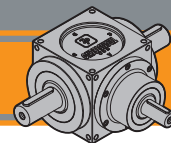

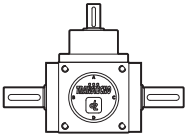

## Designazione

## Classification

RINVIO ANGOLARE / RIGHT-ANGLE BEVEL GEARBOX						
QB	1	R	54	56	B5	1:1
Tipo Type	Forma costruttiva Constructive forms	Albero rinforzato Strengthened shaft	Grandezza Size	IEC 	Forma costruttiva Version	Rapporto Ratio
<b>QB</b> 	<b>1</b> ... <b>68</b> 	<b>R *</b>	<b>54</b> <b>86</b> <b>110</b> <b>134</b> <b>166</b> <b>200</b> <b>250</b> <b>350</b>	<b>56..</b> <b>—</b> <b>160..</b>	<b>B5</b> <b>B14</b>	<b>1:1</b> <b>1:1.5</b> <b>1:2</b> <b>1:3</b> <b>1:4</b>

\* Riferita agli assi A, D, E ed F nell'opzione con albero maschio

\* Referred to axes A, D, E and F in the solid shaft option

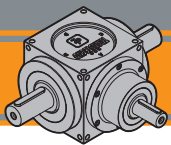

**Sensi di rotazione**

**Direction of rotation**

**Asse B-C integrale / B-C single output axis**

**Asse B-C con Torrette / Axis B-C with Bell housings**

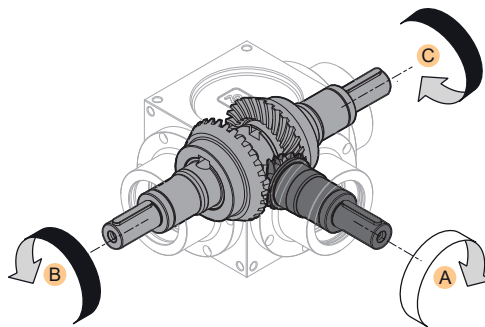
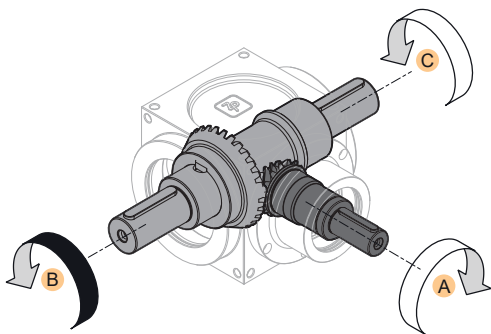

Le uscite B e C, viste frontalmente, hanno sensi di rotazione **opposti**.  
Outputs B and C, seen from the front, have **opposite** directions of rotation.

Le uscite B e C, viste frontalmente, hanno sensi di rotazione **uguali**.  
Outputs B and C, seen from the front, have **equal** directions of rotation.

**Torrette D, E ed F / Bell housings D, E and F**

**Asse B-C con torrette / Axis B-C with bell housings**

**Asse B-C integrale / Integral B-C axis**

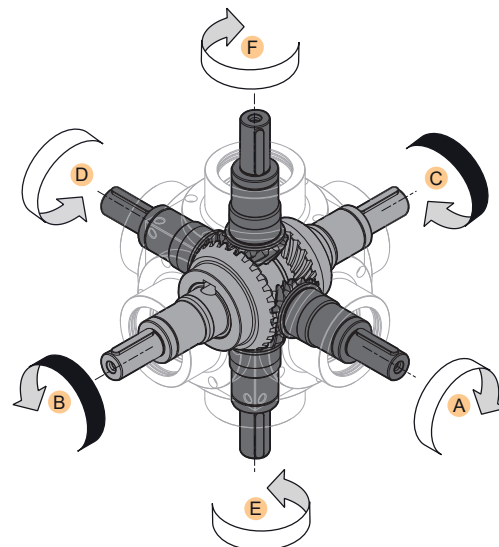
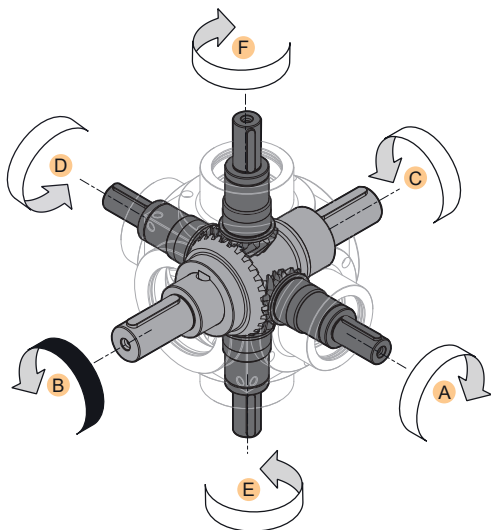

Indipendentemente dal tipo di asse B-C (integrale o con torrette), le torrette D, E ed F hanno senso di rotazione **uguale** alla torretta A.  
Regardless of the B-C axis type (single output axis or with bell housings), bell housings D, E and F have the **same** direction of rotation as bell housing A.

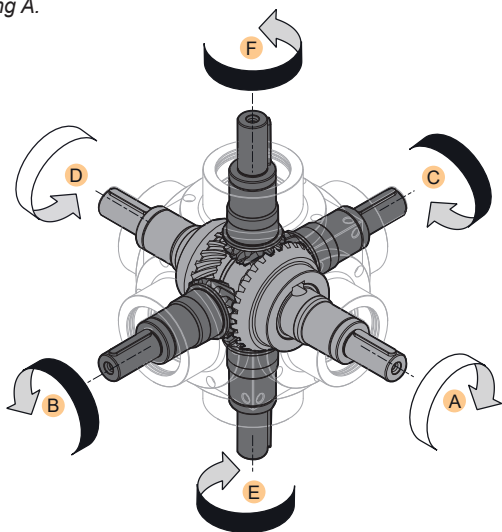





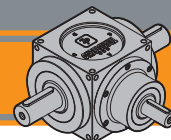

Nel caso specifico della **multiplica** le torrette A e D hanno sensi di rotazione **uguali**. Le torrette B, C, E ed F hanno sensi di rotazione **uguali** tra di loro ma **opposti** ad A e D.

In the specific case of the **multiplex**, bell housings A and D have **equal** directions of rotation. Bell housings B, C, E and F have **equal** but **opposite** directions of rotation to A and D.



## Simbologia

$n_1$	[ $\text{min}^{-1}$ ]	Velocità in ingresso / <i>Input speed</i>
$n_2$	[ $\text{min}^{-1}$ ]	Velocità in uscita / <i>Output speed</i>
$i$		Rapporto di riduzione / <i>Ratio</i>
$P_1$	[kW]	Potenza in entrata / <i>Input power</i>
$M_2$	[Nm]	Coppia nominale in uscita in funzione di $P_1$ / <i>Output torque referred to <math>P_1</math></i>
$P_{n1}$	[kW]	Potenza nominale in entrata / <i>Nominal input power</i>
$M_{n2}$	[Nm]	Coppia nominale in uscita in funzione di $P_{n1}$ / <i>Nominal output torque referred to <math>P_{n1}</math></i>
$sf$		Fattore di servizio / <i>Service factor</i>
$R_1$	[N]	Carico radiale ammissibile in entrata / <i>Permitted input radial load</i>
$A_1$	[N]	Carico assiale ammissibile in entrata / <i>Permitted input axial load</i>
$R_2$	[N]	Carico radiale ammissibile in uscita / <i>Permitted output radial load</i>
$A_2$	[N]	Carico assiale ammissibile in uscita / <i>Permitted output axial load</i>
 [kg]		Peso del solo riduttore / <i>Weight of the gearbox only</i>
		Albero entrata cavo con linguetta / <i>Hollow input shaft with key</i>
		Albero uscita cavo con linguetta / <i>Hollow output shaft with key</i>
		Albero maschio / <i>Solid shaft</i>
		Albero cavo scanalato / <i>Grooved hollow shaft UNI 8953</i>
		Albero cavo con calettatore / <i>Hollow shaft with shrink disc</i>

## Lubrificazione

I rinvii angolari serie QB, sono forniti completi di lubrificante sintetico viscosità 150 ad eccezione della taglia QB54 prevista con grasso minerale 00 EP e pertanto possono essere installati in qualunque posizione di montaggio e non necessitano di manutenzione.

La quantità di lubrificante dipende dalla posizione di montaggio che, se non viene specificata, sarà intesa in pos. M1 (Pos.2).

## Lubrication

The QB series right-angle bevel gearboxes are supplied complete with synthetic lubricant viscosity 150 with the exception of size QB54 supplied with mineral grease 00 EP and can therefore be installed in any mounting position and are maintenance-free.

The quantity of lubricant depends on the mounting position, which, if not specified, will be understood to be in pos. M1 (Pos.2).

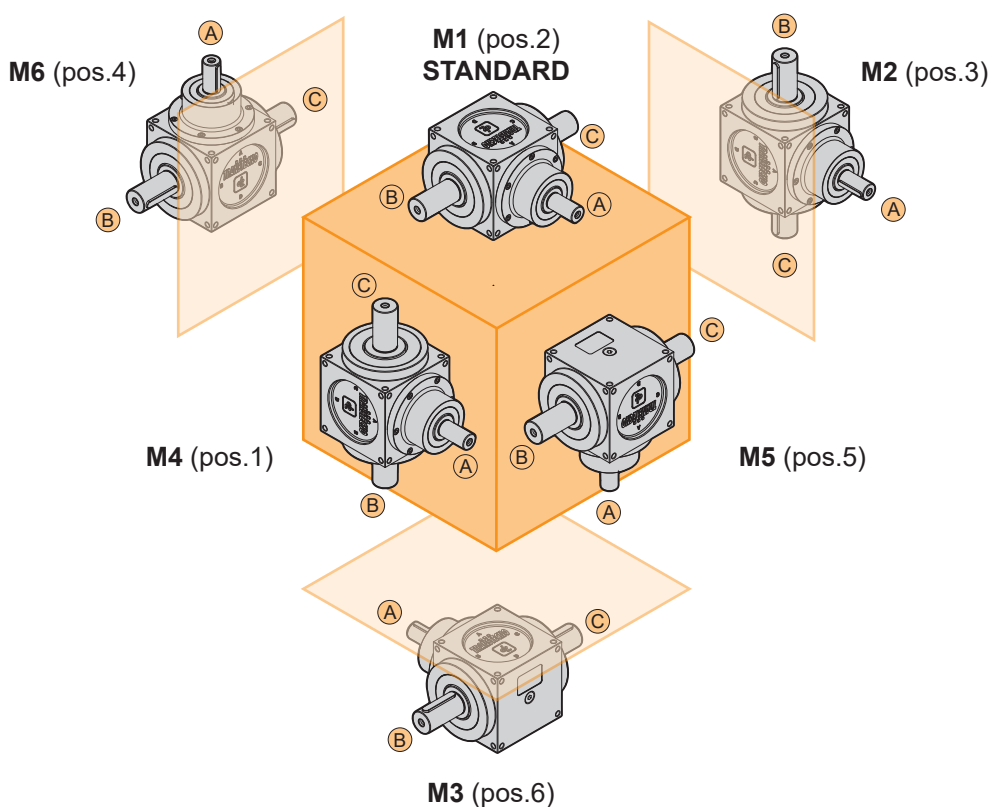

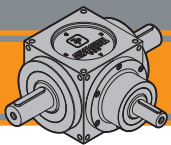

# QB Rinvii angolari Right-angle bevel gearboxes

## Carichi radiali e assiali

## Entrata / Input

## Radial and axial loads

Per carichi radiali o assiali superiori a quelli di tabella si prega di contattare il servizio tecnico

For radial or axial loads higher than those in the table, please contact technical service

n1 [min <sup>-1</sup> ]	i	n2 [min <sup>-1</sup> ]	Torretta A standard Bell housing A standard		Torretta A rinforzata Bell housing A Strengthened		n1 [min <sup>-1</sup> ]	i	n2 [min <sup>-1</sup> ]	Torretta A standard Bell housing A standard		Torretta A rinforzata Bell housing A Strengthened		
			R <sub>1</sub> [N]	A <sub>1</sub> [N]	R <sub>1</sub> [N]	A <sub>1</sub> [N]				R <sub>1</sub> [N]	A <sub>1</sub> [N]	R <sub>1</sub> [N]	A <sub>1</sub> [N]	
50	1	50	*	*	*	*	100	1	100	*	*	*	*	
	1.5	33	600	500	600	500		1.5	67	510	420	510	420	
	2	25						280	280					
	3	17						510	510					
	4	13						510	510					
250	1	250	*	*	*	*	500	1	500	*	*	*	*	
	1.5	167	360	330	360	330		1.5	333	100	280	100	280	
	2	125	*	*	*	*		2	250	*	*	*	*	
	3	83	400	330	400	330		3	167	310	280	310	280	
	4	63						340	340					
750	1	750	*	*	*	*	1000	1	1000	*	*	*	*	
	1.5	500	200	250	200	250		1.5	667	150	240	150	240	
	2	375						500						
	3	250						333	290					
	4	188						250	290					
1500	1	1500	*	*	*	*	2000	1	2000	*	*	*	*	
	1.5	1000	240	210	240	210		1.5	1333	230	200	230	200	
	2	750						1000						
	3	500						667	50					50
	4	375						500	200					200
2500	1	2500	*	*	*	*	3000	1	3000	*	*	*	*	
	1.5	1667	200	190	200	190		1.5	2000	180	180	180	180	
	2	1250						1500						
	3	833						1000						
	4	625						750						
50	1	50	1500	1500	2000	1500	100	1	100	1500	1200	1700	1200	
	1.5	33						67						
	2	25						50						
	3	17						33						
	4	13						25						
250	1	250	1200	1000	1400	1000	500	1	500	1000	800	1100	800	
	1.5	167						333						
	2	125						250						
	3	33						167						
	4	63						125						
750	1	750	900	700	1000	700	1000	1	1000	800	700	1000	700	
	1.5	500						667						
	2	375						500						
	3	250						333						
	4	188						250						
1500	1	1500	800	600	900	600	2000	1	2000	700	600	800	600	
	1.5	1000						1333						
	2	750						1000						
	3	500						667						
	4	375						500						
2500	1	2500	700	600	800	600	3000	1	3000	600	500	700	500	
	1.5	1667						2000						
	2	1250						1500						
	3	833						1000						
	4	625						750						

QB 54

QB 86

\* Contattare il servizio tecnico

\* Contact technical service

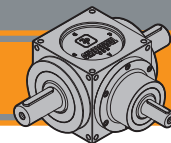

Carichi radiali e assiali

Entrata / Input

Radial and axial loads

Per carichi radiali o assiali superiori a quelli di tabella si prega di contattare il servizio tecnico

For radial or axial loads higher than those in the table, please contact technical service

	n <sub>1</sub> [min <sup>-1</sup> ]	i	n <sub>2</sub> [min <sup>-1</sup> ]	Torretta A standard Bell housing A standard		Torretta A rinforzata Bell housing A Strengthened		n <sub>1</sub> [min <sup>-1</sup> ]	i	n <sub>2</sub> [min <sup>-1</sup> ]	Torretta A standard Bell housing A standard		Torretta A rinforzata Bell housing A Strengthened	
				R <sub>1</sub> [N]	A <sub>1</sub> [N]	R <sub>1</sub> [N]	A <sub>1</sub> [N]				R <sub>1</sub> [N]	A <sub>1</sub> [N]		
QB 110	50	1	50	2100	2300	2800	2300	100	1	100	2100	1900	2400	1900
		1.5	33						1.5	67				
		2	25						2	50				
		3	17						3	33				
	4	13	4	25										
	250	1	250	1900	2400	2000	2400	500	1	500	1600	1900	1700	1900
		1.5	167						1.5	333				
		2	125						2	250				
		3	83						3	167				
	4	63	4	125										
750	1	750	1400	1800	1400	1800	1000	1	1000	1300	1600	1300	1600	
	1.5	500						1.5	667					
	2	375						2	500					
	3	250						3	333					
4	188	4	250											
1500	1	1500	1200	1400	1200	1400	2000	1	2000	1100	1300	1100	1300	
	1.5	1000						1.5	1333					
	2	750						2	1000					
	3	500						3	667					
4	375	4	500											
2500	1	2500	1000	1200	1100	1200	3000	1	3000	1000	1100	1000	1100	
	1.5	1667						1.5	2000					
	2	1250						2	1500					
	3	833						3	1000					
4	625	4	750											
QB 134	50	1	50	2600	3000	3800	3000	100	1	100	2600	2600	3200	2600
		1.5	33						1.5	67				
		2	25						2	50				
		3	17						3	33				
	4	13	4	25										
	250	1	250	2400	3300	2600	3300	500	1	500	2100	2500	2300	2500
		1.5	167						1.5	333				
		2	125						2	250				
		3	83						3	167				
	4	63	4	125										
750	1	750	2100	2500	2300	2500	1000	1	1000	1700	2100	1800	2100	
	1.5	500						1.5	667					
	2	375						2	500					
	3	250						3	333					
4	188	4	250											
1500	1	1500	1600	1800	1600	1800	2000	1	2000	1500	1600	1500	1600	
	1.5	1000						1.5	1333					
	2	750						2	1000					
	3	500						3	667					
4	375	4	500											
2500	1	2500	1400	1500	1400	1500	3000	1	3000	1300	1100	1400	1100	
	1.5	1667						1.5	2000					
	2	1250						2	1500					
	3	833						3	1000					
4	625	4	750											

QB

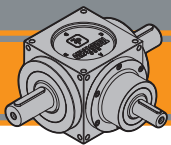

**QB**

**Rinvii angolari**  
Right-angle bevel gearboxes

**Carichi radiali e assiali**

**Entrata / Input**

**Radial and axial loads**

Per carichi radiali o assiali superiori a quelli di tabella si prega di contattare il servizio tecnico

For radial or axial loads higher than those in the table, please contact technical service

**QB 166**

**QB 200**

n1 [min <sup>-1</sup> ]	i	n2 [min <sup>-1</sup> ]	Torretta A standard Bell housing A standard		Torretta A rinforzata Bell housing A Strengthened		n1 [min <sup>-1</sup> ]	i	n2 [min <sup>-1</sup> ]	Torretta A standard Bell housing A standard		Torretta A rinforzata Bell housing A Strengthened	
			R <sub>1</sub> [N]	A <sub>1</sub> [N]	R <sub>1</sub> [N]	A <sub>1</sub> [N]				R <sub>1</sub> [N]	A <sub>1</sub> [N]	R <sub>1</sub> [N]	A <sub>1</sub> [N]
50	1	50	4300	4500	5900	4500	100	1	100	4200	3800	5000	3800
	1.5	33						1.5	67				
	2	25						2	50				
	3	17						3	33				
	4	13					4	25					
250	1	250	3700	3000	4000	3000	500	1	500	3100	2600	3300	2600
	1.5	167						1.5	333				
	2	125						2	250				
	3	83						3	167				
	4	63					4	125					
750	1	750	2800	2300	3000	2300	1000	1	1000	2600	2200	2800	2200
	1.5	500						1.5	667				
	2	375						2	500				
	3	250						3	333				
	4	188					4	250					
1500	1	1500	2300	1900	2500	1900	2000	1	2000	2200	1800	2400	1800
	1.5	1000						1.5	1333				
	2	750						2	1000				
	3	500						3	667				
	4	375					4	500					
2500	1	2500	2100	1700	2200	1700	3000	1	3000	2000	1600	2100	1600
	1.5	1667						1.5	2000				
	2	1250						2	1500				
	3	833						3	1000				
	4	625					4	750					
50	1	50	6300	5600	6900	5600	100	1	100	5800	4700	5800	4700
	1.5	33						1.5	67				
	2	25						2	50				
	3	17						3	33				
	4	13					4	25					
250	1	250	4600	3800	4600	3800	500	1	500	3900	3100	3900	3100
	1.5	167						1.5	333				
	2	125						2	250				
	3	33						3	167				
	4	63					4	125					
750	1	750	3500	2900	3500	2900	1000	1	1000	2800	2300	2800	2300
	1.5	500						1.5	667				
	2	375	3500	2900	3500	2900		2	500	3300	2700	3300	2700
	3	250						3	333				
	4	188					4	250					
1500	1	1500	2400	2000	2400	2000	2000	1	2000	2400	2000	2400	2000
	1.5	1000						1.5	1333				
	2	750	2400	2000	2400	2000		2	1000	2800	2200	2800	2200
	3	500						3	667				
	4	375					4	500					
2500	1	2500	2300	1900	2300	1900	2500	1	2500	2600	2100	2600	2100
	1.5	1667						1.5	1667				
	2	1250	2600	2100	2600	2100		2	1250	2600	2100	2600	2100
	3	833						3	833				
	4	625					4	625					

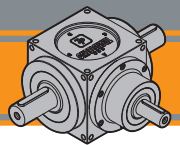

### Carichi radiali e assiali

### Entrata / Input

### Radial and axial loads

Per carichi radiali o assiali superiori a quelli di tabella si prega di contattare il servizio tecnico

For radial or axial loads higher than those in the table, please contact technical service

	n <sub>1</sub> [min <sup>-1</sup> ]	i	n <sub>2</sub> [min <sup>-1</sup> ]	Torretta A standard <i>Bell housing A standard</i>		Torretta A rinforzata <i>Bell housing A Strengthened</i>		n <sub>1</sub> [min <sup>-1</sup> ]	i	n <sub>2</sub> [min <sup>-1</sup> ]	Torretta A standard <i>Bell housing A standard</i>		Torretta A rinforzata <i>Bell housing A Strengthened</i>		
				R <sub>1</sub> [N]	A <sub>1</sub> [N]	R <sub>1</sub> [N]	A <sub>1</sub> [N]				R <sub>1</sub> [N]	A <sub>1</sub> [N]	R <sub>1</sub> [N]	A <sub>1</sub> [N]	
QB 250	50	1	50	10800	11100	13700	11100	100	1	100	10500	9300	11500	9300	
		1.5	33												
		2	25												
		3	17												
	250	1	1	250	9200	7400	9700	7400	500	1	500	7700	6300	8000	6300
			1.5	167											
			2	125											
			3	83											
	750	1	1	750	7000	5500	7000	5600	1000	1	1000	6000	5000	6000	5000
			1.5	500											
			2	375											
			3	250											
	1500	1	1	1500	4500	4500	4500	4500	2000	1	2000	4000	3500	3500	4000
			1.5	1000											
			2	750											
			3	500											
QB 350	50	1	50	13600	20500	25000	20500	100	1	100	13200	18000	22000	18000	
		1.5	33												
		2	25												
		3	17												
	250	1	1	250	12600	14000	20000	14000	500	1	500	12300	11500	14000	11500
			1.5	167											
			2	125											
			3	33											
	750	1	1	750	12000	10400	13000	10400	1000	1	1000	11500	9700	12000	9700
			1.5	500											
			2	375											
			3	250											
	1500	1	1	1500	10600	8700	11000	8700	9000	1	1500	9000	8700	9500	8700
			1.5	1000											
			2	750											
			3	500											

QB

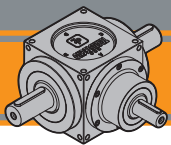

# QB Rinvii angolari Right-angle bevel gearboxes

## Carichi radiali e assiali

## Entrata / Input

## Radial and axial loads

Quando il carico radiale risultante non è applicato sulla mezzzeria dell'albero occorre calcolare quello effettivo con la seguente formula:

When the resulting radial load is not applied on the centre line of the shaft it is necessary to calculate the effective load with the following formula:

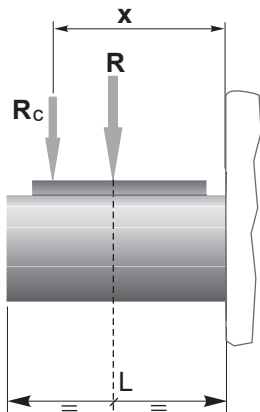

$$R_c = \frac{R \cdot a}{(b+x)} \leq R_{..MAX}$$

$$R \leq R_c$$

*a, b = valori riportati nella tabella*  
*a, b = values given in the table*

	i	Torretta A standard Bell housing A standard			Torretta A rinforzata Bell housing A Strengthened		
		a	b	R <sub>max</sub> [N]	a	b	R <sub>max</sub> [N]
QB54	1	55	43.5	*	61	43.5	*
	1.5			600			600
	2						
	3						
	4						
QB86	1	63.5	48.5	1500	73.5	48.5	2000
	1.5						
	2						
	3						
	4						
QB110	1	83	63	2100	90.5	63	2800
	1.5						
	2						
	3						
	4						
QB134	1	98	73	2600	106	73	3800
	1.5						
	2						
	3						
	4						
QB166	1	110	77.5	4300	122.5	77.5	5900
	1.5						
	2						
	3						
	4						
QB200	1	128	86	6300	141	86	6900
	1.5						
	2						
	3						
	4						
QB250	1	150.5	100.5	10800	170.5	100.5	13700
	1.5						
	2						
	3						
	4						
QB350	1	222.5	162.5	13600	247.5	162.5	25000
	1.5						
	2						
	3						
	4						

\* Contattare il servizio tecnico

\* Contact technical service



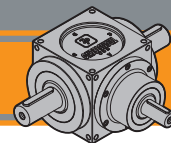

**Carichi radiali e assiali**

**Uscita / Output**

**Radial and axial loads**

Per carichi radiali o assiali superiori a quelli di tabella si prega di contattare il servizio tecnico

For radial or axial loads higher than those in the table, please contact technical service

	n1 [min <sup>-1</sup> ]	i	n2 [min <sup>-1</sup> ]	Asse B-C integrale Integral axis B-C		Asse B-C con Torrette Axis B-C with bell housings		n1 [min <sup>-1</sup> ]	i	n2 [min <sup>-1</sup> ]	Asse B-C integrale Integral axis B-C		Asse B-C con Torrette Axis B-C with bell housings	
				R <sub>2</sub> [N]	A <sub>2</sub> [N]	R <sub>2</sub> [N]	A <sub>2</sub> [N]				R <sub>2</sub> [N]	A <sub>2</sub> [N]	R <sub>2</sub> [N]	A <sub>2</sub> [N]
<b>QB 54</b>	<b>50</b>	1	50	470	530	*	*	<b>100</b>	1	100	120	160	*	*
		1.5	33	650		650	530		1.5	67	550	440	550	440
		2	25						2	50			450	
		3	17						3	33			550	
		4	13						4	25				
	<b>250</b>	1	250	*	*	*	*	<b>500</b>	1	500	*	*	*	*
		1.5	167	440	350	360	350		1.5	333	370	300	200	300
		2	125			20	230		2	250	340		*	*
		3	83			440	350		3	167	370		370	300
		4	63						4	125				
<b>750</b>	1	750	*	*	*	*	<b>1000</b>	1	1000	*	*	*	*	
	1.5	500	300	270	*	270		1.5	667	230	250	*	*	
	2	375	270		*	*		2	500	220		*	*	
	3	250	330		290	270		3	333	310		250	250	
	4	188			330	270		4	250			310	310	250
<b>1500</b>	1	1500	*	*	*	*	<b>2000</b>	1	2000	*	*	*	*	
	1.5	1000	160	160	*	*		1.5	1333	110	100	*	*	
	2	750	170	180	120	220		2	1000	140	150	90	210	
	3	500	280	230	280	220		3	667	260	210	260	210	
	4	375							4	500				
<b>2500</b>	1	2500	*	*	*	*	<b>3000</b>	1	3000	*	*	*	*	
	1.5	1667	80	80	*	*		1.5	2000	*	*	*	*	
	2	1250	140	140	20	200		2	1500	120	120	20	190	
	3	833	240	200	240	200		3	1000	230	190	220	190	
	4	625							4	750				
<b>QB 86</b>	<b>50</b>	1	50	2000	1600	2000	1600	<b>100</b>	1	100	1700	1400	1700	1400
		1.5	33						1.5	67				
		2	25						2	50				
		3	17						3	33				
		4	13						4	25				
	<b>250</b>	1	250	1400	1500	1400	2400	<b>500</b>	1	500	1100	1100	1100	1800
		1.5	167						1.5	333				
		2	125						2	250				
		3	33						3	167				
		4	63						4	125				
	<b>750</b>	1	750	1000	900	1000	1600	<b>1000</b>	1	1000	1000	800	1000	1400
		1.5	500						1.5	667				
		2	375						2	500				
		3	250						3	333				
		4	188						4	250				
	<b>1500</b>	1	1500	1000	700	900	1300	<b>2000</b>	1	2000	800	700	800	1000
		1.5	1000						1.5	1333				
		2	750						2	1000				
		3	500						3	667				
		4	375						4	500				
<b>2500</b>	1	2500	800	600	800	800	<b>3000</b>	1	3000	700	600	700	700	
	1.5	1667						1.5	2000					
	2	1250						2	1500					
	3	833						3	1000					
	4	625						4	750					

\* Contattare il servizio tecnico

\* Contact technical service

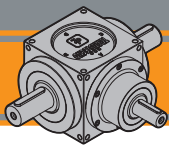

**QB**

**Rinvii angolari**  
Right-angle bevel gearboxes

**Carichi radiali e assiali**

**Uscita / Output**

**Radial and axial loads**

Per carichi radiali o assiali superiori a quelli di tabella si prega di contattare il servizio tecnico

For radial or axial loads higher than those in the table, please contact technical service

	n1 [min <sup>-1</sup> ]	i	n2 [min <sup>-1</sup> ]	Asse B-C integrale Integral axis B-C		Asse B-C con Torrette Axis B-C with bell housings		n1 [min <sup>-1</sup> ]	i	n2 [min <sup>-1</sup> ]	Asse B-C integrale Integral axis B-C		Asse B-C con Torrette Axis B-C with bell housings	
				R <sub>2</sub> [N]	A <sub>2</sub> [N]	R <sub>2</sub> [N]	A <sub>2</sub> [N]				R <sub>2</sub> [N]	A <sub>2</sub> [N]	R <sub>2</sub> [N]	A <sub>2</sub> [N]
<b>QB 110</b>	<b>50</b>	1	50	2800	2300	2800	2300	<b>100</b>	1	100	2400	1900	2400	1900
		1.5	33						1.5	67				
		2	25						2	50				
		3	17						3	33				
	4	13	4	25										
	<b>250</b>	1	250	1900	3100	2000	3200	<b>500</b>	1	500	1600	2400	1700	2500
		1.5	167						1.5	333				
		2	125						2	250				
		3	83						3	167				
	4	63	4	125										
<b>750</b>	1	750	1400	2100	1400	2300	<b>1000</b>	1	1000	1300	2000	1300	2100	
	1.5	500						1.5	667					
	2	375						2	500					
	3	250						3	333					
4	188	4	250											
<b>1500</b>	1	1500	1200	1800	1200	1900	<b>2000</b>	1	2000	1100	1500	1100	1700	
	1.5	1000						1.5	1333					
	2	750						2	1000					
	3	500						3	667					
4	375	4	500											
<b>2500</b>	1	2500	1100	1500	1100	1600	<b>3000</b>	1	3000	1000	1400	1000	1500	
	1.5	1667						1.5	2000					
	2	1250						2	1500					
	3	833						3	1000					
4	625	4	750											
<b>QB 134</b>	<b>50</b>	1	50	3800	3100	3800	3100	<b>100</b>	1	100	3200	2600	3200	2600
		1.5	33						1.5	67				
		2	25						2	50				
		3	17						3	33				
	4	13	4	25										
	<b>250</b>	1	250	2600	3700	2600	4200	<b>500</b>	1	500	2100	2700	2300	3200
		1.5	167						1.5	333				
		2	125						2	250				
		3	33						3	167				
	4	63	4	125										
<b>750</b>	1	750	1900	2500	1900	2800	<b>1000</b>	1	1000	1800	2300	1800	2600	
	1.5	500						1.5	667					
	2	375						2	500					
	3	250						3	333					
4	188	4	250											
<b>1500</b>	1	1500	1600	1900	1600	2400	<b>2000</b>	1	2000	1500	1800	1500	2200	
	1.5	1000						1.5	1333					
	2	750						2	1000					
	3	500						3	667					
4	375	4	500											
<b>2500</b>	1	2500	1400	1700	1400	2000	<b>3000</b>	1	3000	1400	1100	1400	1100	
	1.5	1667						1.5	2000					
	2	1250						2	1500					
	3	833						3	1000					
4	625	4	750											

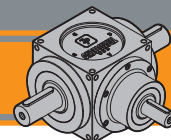

### Carichi radiali e assiali

### Uscita / Output

### Radial and axial loads

Per carichi radiali o assiali superiori a quelli di tabella si prega di contattare il servizio tecnico

For radial or axial loads higher than those in the table, please contact technical service

	n1 [min <sup>-1</sup> ]	i	n2 [min <sup>-1</sup> ]	Asse B-C integrale Integral axis B-C		Asse B-C con Torrette Axis B-C with bell housings		n1 [min <sup>-1</sup> ]	i	n2 [min <sup>-1</sup> ]	Asse B-C integrale Integral axis B-C		Asse B-C con Torrette Axis B-C with bell housings		
				R <sub>2</sub> [N]	A <sub>2</sub> [N]	R <sub>2</sub> [N]	A <sub>2</sub> [N]				R <sub>2</sub> [N]	A <sub>2</sub> [N]	R <sub>2</sub> [N]	A <sub>2</sub> [N]	
<b>QB 166</b>	<b>50</b>	1	50	5900	4800	5900	4800	<b>100</b>	1	100	5000	4000	5000	4000	
		1.5	33						1.5	67					
		2	25						2	50					
		3	17						3	33					
		4	13	4	25										
		<b>250</b>	1	250	4500	3200	4000	3200	<b>500</b>	1	500	4500	2700	3300	2700
	1.5		167	1.5						333					
	2		125	2						250					
	3		83	3						167					
		4	63	4	125										
	<b>750</b>	1	750	4200	2400	3000	2400	<b>1000</b>	1	1000	2800	2300	2800	2300	
1.5		500	1.5						667						
2		375	2						500						
3		250	3						333						
	4	188	4	250											
	<b>1500</b>	1	1500	2500	2100	2500	2100	<b>2000</b>	1	2000	2400	1900	2400	1900	
1.5		1000	1.5						1333						
2		750	2						1000						
3		500	3						667						
	4	375	4	500											
	<b>2500</b>	1	2500	2200	1800	2200	1800	<b>3000</b>	1	3000	2100	1700	2100	1700	
1.5		1667	1.5						2000						
2		1250	2						1500						
3		833	3						1000						
	4	625	4	750											
<b>QB 200</b>	<b>50</b>	1	50	6900	5600	6900	5600	<b>100</b>	1	100	5800	4700	5800	4700	
		1.5	33						1.5	67					
		2	25						2	50					
		3	17						3	33					
		4	13	4	25										
		<b>250</b>	1	250	4600	3800	4600	3800	<b>500</b>	1	500	4600	3200	3900	3200
	1.5		167	1.5						333					
	2		125	2						250					
	3		83	3						167					
		4	63	4	125										
	<b>750</b>	1	750	4000	2900	3500	2900	<b>1000</b>	1	1000	3300	2700	3100	2700	
1.5		500	1.5						667						
2		375	2						500						
3		250	3						333						
	4	188	4	250											
	<b>1500</b>	1	1500	3000	2400	2800	2400	<b>2000</b>	1	2000	2800	2200	2700	2200	
1.5		1000	1.5						1333						
2		750	2						1000						
3		500	3						667						
	4	375	4	500											
	<b>2500</b>	1	2500	2600	2100	2600	2100								
1.5		1667													
2		1250													
3		833													
	4	625													

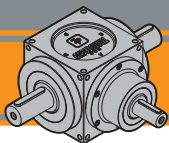

**QB**

**Rinvii angolari**  
Right-angle bevel gearboxes

**Carichi radiali e assiali**

**Uscita / Output**

**Radial and axial loads**

Per carichi radiali o assiali superiori a quelli di tabella si prega di contattare il servizio tecnico

For radial or axial loads higher than those in the table, please contact technical service

	n1 [min <sup>-1</sup> ]	i	n2 [min <sup>-1</sup> ]	Asse B-C integrale Integral axis B-C		Asse B-C con Torrette Axis B-C with bell housings		n1 [min <sup>-1</sup> ]	i	n2 [min <sup>-1</sup> ]	Asse B-C integrale Integral axis B-C		Asse B-C con Torrette Axis B-C with bell housings	
				R <sub>2</sub> [N]	A <sub>2</sub> [N]	R <sub>2</sub> [N]	A <sub>2</sub> [N]				R <sub>2</sub> [N]	A <sub>2</sub> [N]	R <sub>2</sub> [N]	A <sub>2</sub> [N]
<b>QB 250</b>	<b>50</b>	1	50	13700	11100	13700	11100	<b>100</b>	1	100	11500	9300	11500	9300
		1.5	33						1.5	67				
		2	25						2	50				
		3	17						3	33				
	4	13	4	25										
	<b>250</b>	1	250	9500	7400	9200	7400	<b>500</b>	1	500	9200	6300	7700	6300
		1.5	167						1.5	333				
		2	125						2	250				
		3	83						3	167				
	4	63	4	125										
	<b>750</b>	1	750	8500	5600	7000	5600	<b>1000</b>	1	1000	6500	5300	6500	5300
		1.5	500						1.5	667				
		2	375						2	500				
		3	250						3	333				
	4	188	4	250										
	<b>1500</b>	1	1500	5900	4700	5500	4700	<b>2000</b>	1	2000	5500	4400	5000	4400
1.5		1000	1.5						1333					
2		750	2						1000					
3		500	3						667					
4	375	4	500											

<b>QB 350</b>	<b>50</b>	1	50	20800	37000	22100	25000	<b>100</b>	1	100	20100	32000	21600	22000
		1.5	33						1.5	67				
		2	25						2	50				
		3	17						3	33				
	4	13	4	25										
	<b>250</b>	1	250	19900	24000	20000	17000	<b>500</b>	1	500	19000	18000	16000	13500
		1.5	167						1.5	333				
		2	125						2	250				
		3	83						3	167				
	4	63	4	125										
	<b>750</b>	1	750	16000	14000	13500	11500	<b>1000</b>	1	1000	12200	9900	12200	9900
		1.5	500						1.5	667				
		2	375						2	500				
		3	250						3	333				
	4	188	4	250										
	<b>1500</b>	1	1500	11000	8900	11000	8900	<b>2000</b>	1	2000	11000	8900	11000	8900
1.5		1000	1.5						1333					
2		750	2						1000					
3		500	3						667					
4	375	4	500											

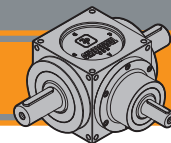

**Carichi radiali e assiali**

**Uscita / Output**

**Radial and axial loads**

Quando il carico radiale risultante non è applicato sulla mezza-  
ria dell'albero occorre calcolare quello effettivo con la seguente  
formula:

When the resulting radial load is not applied on the centre line  
of the shaft it is necessary to calculate the effective load with the  
following formula:

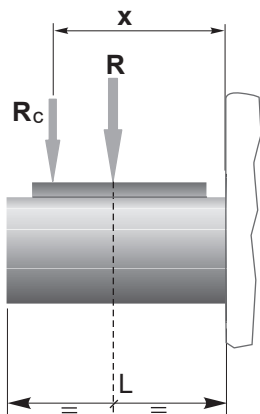

$$R_c = \frac{R \cdot a}{(b+x)} \leq R_{..MAX}$$

$$R \leq R_c$$

*a, b = valori riportati nella tabella*  
*a, b = values given in the table*

	i	Asse B-C integrale Integral axis B-C			Asse B-C con Torrette Axis B-C with bell housings		
		a	b	R <sub>max</sub> [N]	a	b	R <sub>max</sub> [N]
<b>QB54</b>	1	81	63.5	470	59.5	42	*
	1.5			650			650
	2						
	3						
	4						
<b>QB86</b>	1	120	95	2000	73.5	48.5	2000
	1.5						
	2						
	3						
	4						
<b>QB110</b>	1	145	117.5	2800	90.5	63	2800
	1.5						
	2						
	3						
	4						
<b>QB134</b>	1	177	144.5	3800	106	73	3800
	1.5						
	2						
	3						
	4						
<b>QB166</b>	1	221.5	176.5	5900	122.5	77.5	5900
	1.5						
	2						
	3						
	4						
<b>QB200</b>	1	268	213	6900	141	86	6900
	1.5						
	2						
	3						
	4						
<b>QB250</b>	1	325	255	13700	170.5	100.5	13700
	1.5						
	2						
	3						
	4						
<b>QB350</b>	1	445.5	360.5	20800	247.5	162.5	22100
	1.5						
	2						
	3						
	4						

\* Contattare il servizio tecnico  
\* Contact technical service

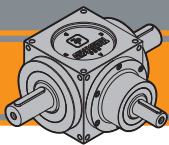

# QB Rinvii angolari Right-angle bevel gearboxes

## Dati tecnici

## Technical data

	i	n <sub>1</sub> [min <sup>-1</sup> ]	n <sub>2</sub> [min <sup>-1</sup> ]	M <sub>n2</sub> [Nm]	P <sub>n1</sub> [kW]	n <sub>1</sub> [min <sup>-1</sup> ]	n <sub>2</sub> [min <sup>-1</sup> ]	M <sub>n2</sub> [Nm]	P <sub>n1</sub> [kW]	n <sub>1</sub> [min <sup>-1</sup> ]	n <sub>2</sub> [min <sup>-1</sup> ]	M <sub>n2</sub> [Nm]	P <sub>n1</sub> [kW]	n <sub>1</sub> [min <sup>-1</sup> ]	n <sub>2</sub> [min <sup>-1</sup> ]	M <sub>n2</sub> [Nm]	P <sub>n1</sub> [kW]				
QB 54	1	50	50	27	0.15	100	100	26	0.28	250	250	25	0.68	500	500	22.5	1.2	750	750	20	1.6
	1.5		33	13	0.05		67	12.5	0.09		167	12	0.22		333	11.5	0.42		500	11.5	0.63
	2		25	19	0.05		50	18.5	0.10		125	18	0.25		250	16	0.44		375	14.5	0.59
	3		17	10	0.02		33	10	0.04		83	9.5	0.09		167	9.5	0.17		250	9.5	0.26
	4		13	7	0.01		25	6.5	0.02		63	6.5	0.04		125	6.5	0.09		188	6.5	0.13
QB 86	1	50	50	72	0.39	100	100	70	0.76	250	250	68	1.9	500	500	66	3.6	750	750	64	5.2
	1.5		33	56	0.20		67	55	0.40		167	54	1.0		333	53	1.9		500	52	2.8
	2		25	53	0.14		50	52	0.28		125	51	0.70		250	50	1.4		375	49	2.0
	3		17	38	0.07		33	38	0.14		83	37	0.13		167	37	0.67		250	36	1.0
	4		13	23	0.03		25	22	0.06		63	22	0.15		125	22	0.30		188	21	0.4
QB 110	1	50	50	140	0.76	100	100	135	1.5	250	250	130	3.5	500	500	120	6.5	750	750	115	9.4
	1.5		33	122	0.44		67	120	0.87		167	117	2.1		333	113	4.1		500	110	6.0
	2		25	110	0.30		50	108	0.59		125	105	1.4		250	100	2.7		375	95	3.9
	3		17	80	0.15		33	80	0.29		83	78	0.71		167	76	1.4		250	74	2.0
	4		13	65	0.09		25	63	0.17		63	60	0.41		125	56	0.76		188	54	1.1
QB 134	1	50	50	260	1.4	100	100	255	2.8	250	250	245	6.7	500	500	220	12	750	750	215	18
	1.5		33	235	0.85		67	230	1.7		167	220	4.0		333	200	7.3		500	195	11
	2		25	205	0.56		50	200	1.1		125	195	2.7		250	180	4.9		375	175	7.2
	3		17	155	0.29		33	150	0.55		83	145	1.3		167	140	2.5		250	135	3.7
	4		13	120	0.17		25	115	0.31		63	110	0.75		125	106	1.4		188	104	2.1
QB 166	1	50	50	610	3.3	100	100	600	6.5	250	250	590	16	500	500	545	30	750	750	530	43
	1.5		33	520	1.9		67	510	3.7		167	490	8.9		333	450	16		500	440	24
	2		25	500	1.4		50	490	2.7		125	475	6.5		250	435	12		375	425	17
	3		17	375	0.70		33	365	1.3		83	355	3.2		167	325	5.9		250	320	8.7
	4		13	320	0.45		25	310	0.85		63	300	2.0		125	275	3.7		188	270	5.5
QB 200	1	50	50	1250	6.8	100	100	1220	13	250	250	1115	30	500	500	1015	55	750	750	950	78
	1.5		33	1100	4.0		67	1070	7.8		167	980	18		333	910	33		500	850	46
	2		25	1000	2.7		50	980	5.3		125	900	12		250	830	23		375	775	32
	3		17	685	1.3		33	670	2.4		83	650	5.9		167	600	11		250	550	15
	4		13	540	0.77		25	530	1.45		63	510	3.5		125	470	6.4		188	435	8.9
QB 250	1	50	50	2500	14	100	100	2450	27	250	250	2250	61	500	500	2000	109	750	750	1750	143
	1.5		33	1800	6.5		67	1750	13		167	1600	29		333	1570	57		500	1450	79
	2		25	1830	5.0		50	1800	9.8		125	1650	22		250	1600	44		375	1500	61
	3		17	1350	2.5		33	1320	4.8		83	1290	12		167	1200	22		250	1110	30
	4		13	1140	1.6		25	1120	3.1		63	1080	7.4		125	1000	14		188	870	18
QB 350	1	50	50	6650	36	100	100	6500	71	250	250	5800	158	500	500	5400	295	750	750	4700	384
	1.5		33	6500	23		67	6350	46		167	5800	105		333	5350	195		500	4700	256
	2		25	5200	14		50	5100	28		125	4700	64		250	4300	117		375	4000	164
	3		17	4850	9.0		33	4750	17		83	4400	40		167	4100	75		250	3800	104
	4		13	4050	5.7		25	3950	11		63	3650	25		125	3350	46		188	3150	64

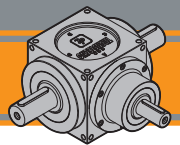

### Dati tecnici

### Technical data

	i	n <sub>1</sub> [min <sup>-1</sup> ]	n <sub>2</sub> [min <sup>-1</sup> ]	M <sub>n2</sub> [Nm]	P <sub>n1</sub> [kW]	n <sub>1</sub> [min <sup>-1</sup> ]	n <sub>2</sub> [min <sup>-1</sup> ]	M <sub>n2</sub> [Nm]	P <sub>n1</sub> [kW]	n <sub>1</sub> [min <sup>-1</sup> ]	n <sub>2</sub> [min <sup>-1</sup> ]	M <sub>n2</sub> [Nm]	P <sub>n1</sub> [kW]	n <sub>1</sub> [min <sup>-1</sup> ]	n <sub>2</sub> [min <sup>-1</sup> ]	M <sub>n2</sub> [Nm]	P <sub>n1</sub> [kW]	n <sub>1</sub> [min <sup>-1</sup> ]	n <sub>2</sub> [min <sup>-1</sup> ]	M <sub>n2</sub> [Nm]	P <sub>n1</sub> [kW]	
<b>QB 54</b>	1	1000	1000	19	2.1	1500	1500	17	2.8	2000	2000	16	3.5	2500	2500	15	4.1	3000	3000	14	4.6	
	1.5		667	11.5	0.8		1000	1000	11		1.2	1333	10.5		1.5	1667	10		1.8	2000	10	2.2
	2		500	14	0.8		750	13	1.1		1000	12	1.3		1250	11	1.5		1500	10.5	1.7	
	3		333	9	0.3		500	9	0.49		667	8.5	0.62		833	8.5	0.77		1000	8	0.87	
	4		250	6	0.2		375	6	0.25		500	5.5	0.30		625	5.5	0.37		750	5.5	0.45	
<b>QB 86</b>	1	1000	1000	62	6.8	1500	1500	60	10	2000	2000	55	12	2500	2500	52	14	3000	3000	50	16	
	1.5		667	51	3.7		1000	50	5.5		1333	45	6.5		1667	42	7.6		2000	40	9	
	2		500	47	2.6		750	45	3.7		1000	42	4.6		1250	40	5.5		1500	38	6.2	
	3		333	36	1.3		500	35	1.9		667	33	2.4		833	32	2.9		1000	31	3.4	
	4		250	21	0.6		375	21	0.9		500	20	1.1		625	19	1.3		750	19	1.6	
<b>QB 110</b>	1	1000	1000	110	12	1500	1500	105	17	2000	2000	95	21	2500	2500	90	25	3000	3000	85	28	
	1.5		667	100	7.3		1000	95	10		1333	90	13		1667	85	15		2000	80	17	
	2		500	92	5.0		750	90	7.4		1000	85	9		1250	80	11		1500	75	12	
	3		333	72	2.6		500	70	3.8		667	65	4.7		833	60	5.5		1000	55	6.0	
	4		250	52	1.4		375	50	2.0		500	48	2.6		625	46	3.1		750	44	3.6	
<b>QB 134</b>	1	1000	1000	210	23	1500	1500	200	33	2000	2000	180	39	2500	2500	170	46	3000	3000	165	54	
	1.5		667	190	14		1000	185	20		1333	170	25		1667	165	30		2000	160	35	
	2		500	170	9.3		750	165	13		1000	155	17		1250	150	20		1500	145	24	
	3		333	130	4.7		500	125	6.8		667	120	8.7		833	115	10		1000	110	12	
	4		250	102	2.8		375	100	4.1		500	92	5.0		625	88	6.0		750	85	7.0	
<b>QB 166</b>	1	1000	1000	500	55	1500	1500	470	77	2000	2000	440	96	2500	2500	420	115	3000	3000	380	124	
	1.5		667	430	31		1000	400	44		1333	380	55		1667	340	62		2000	320	70	
	2		500	400	22		750	380	31		1000	350	38		1250	330	45		1500	300	49	
	3		333	310	11		500	300	16		667	280	20		833	260	24		1000	250	27	
	4		250	250	6.8		375	240	10		500	220	12		625	210	14		750	200	16	
<b>QB 200</b>	1	1000	1000	905	99	1500	1500	810	133	2000	2000	730	159	2500	2500	650	177	3000	3000	600	195	
	1.5		667	800	58		1000	750	82		1333	630	92		1667	580	105		2000	550	115	
	2		500	760	41		750	630	52		1000	600	65		1250	550	75		1500	500	85	
	3		333	510	19		500	480	26		667	465	34		833	450	41		1000	400	45	
	4		250	425	12		375	400	16		500	360	20		625	350	24		750	300	30	
<b>QB 250</b>	1	1000	1000	1650	180	1500	1500	1500	245	2000	2000	1400	305	2500	2500	1250	305	3000	3000	1100	305	
	1.5		667	1350	98		1000	1300	142		1333	1250	182		1667	1100	182		2000	1000	182	
	2		500	1380	75		750	1250	102		1000	1200	131		1250	1100	131		1500	1000	131	
	3		333	1050	38		500	980	53		667	930	68		833	850	68		1000	750	68	
	4		250	815	22		375	800	33		500	780	43		625	750	43		750	650	43	
<b>QB 350</b>	1	1000	1000	4300	469	1500	1500	4000	654	2000	2000	3600	954	2500	2500	3200	954	3000	3000	2800	954	
	1.5		667	4400	320		1000	4200	458		1333	3800	654		1667	3400	654		2000	3000	654	
	2		500	3750	205		750	3600	295		1000	3450	417		1250	3200	417		1500	2800	417	
	3		333	3550	129		500	3450	188		667	3250	278		833	3050	278		1000	2650	278	
	4		250	2950	80		375	2850	117		500	2850	117		625	2650	117		750	2450	117	

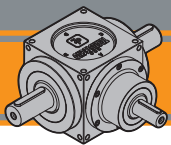

# QB Rinvii angolari Right-angle bevel gearboxes

## Forme costruttive

## Constructive forms

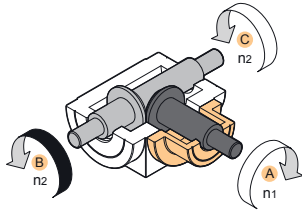
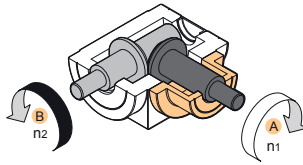
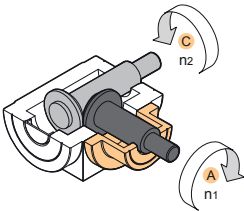
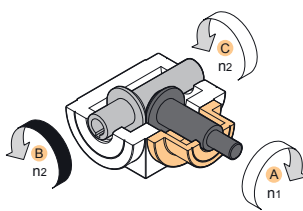
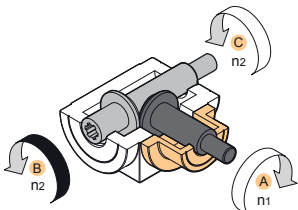
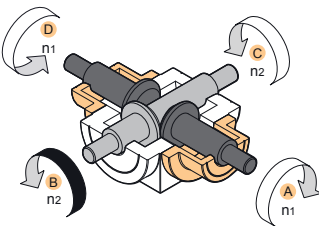
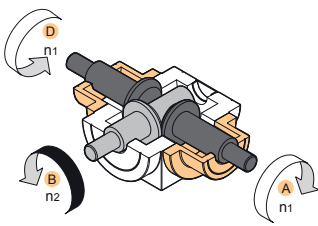
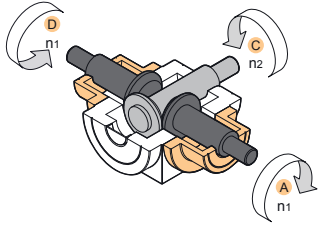
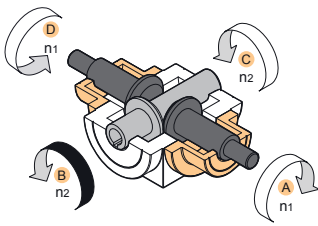
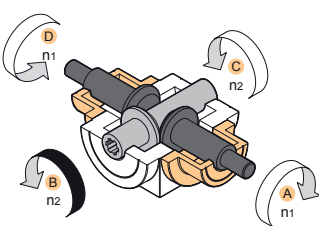
<p><b>Tipo</b> <b>1</b> → <b>1 mm</b> <b>2.1 mm</b> <b>6.1 mm</b></p>  <p><math>i =</math> <math>i =</math></p> <p>1:1 1:1.5 1:2 1:3 1:4</p> <p><b>A</b> <b>B</b> <b>C</b></p>	<p><b>Tipo</b> <b>2</b> → <b>1 mm</b> <b>2.1 mm</b> <b>6.2 mm</b></p>  <p><math>i =</math> <math>i =</math></p> <p>1:1 1:1.5 1:2 1:3 1:4</p> <p><b>A</b> <b>B</b></p>
<p><b>Tipo</b> <b>3</b> → <b>1 mm</b> <b>2.1 mm</b> <b>6.3 mm</b></p>  <p><math>i =</math> <math>i =</math></p> <p>1:1 1:1.5 1:2 1:3 1:4</p> <p><b>A</b> <b>C</b></p>	<p><b>Tipo</b> <b>4</b> → <b>1 mm</b> <b>2.1 mm</b> <b>6.4 mm</b></p>  <p><math>i =</math> <math>i =</math></p> <p>1:1 1:1.5 1:2 1:3 1:4</p> <p><b>A</b> <b>B</b> <b>C</b></p>
<p><b>Tipo</b> <b>5</b> → <b>1 mm</b> <b>2.1 mm</b> <b>6.5 mm</b></p>  <p><math>i =</math> <math>i =</math></p> <p>1:1 1:1.5 1:2 1:3 1:4</p> <p><b>A</b> <b>B</b> <b>C</b></p>	<p><b>Tipo</b> <b>6</b> → <b>1 mm</b> <b>2.1 mm</b> <b>3 mm</b> <b>6.1 mm</b></p>  <p><math>i =</math> <math>i =</math></p> <p>1:1 1:1.5 1:2 1:3 1:4</p> <p><b>A</b> <b>B</b> <b>D</b> <b>C</b></p>
<p><b>Tipo</b> <b>7</b> → <b>1 mm</b> <b>2.1 mm</b> <b>3 mm</b> <b>6.2 mm</b></p>  <p><math>i =</math> <math>i =</math></p> <p>1:1 1:1.5 1:2 1:3 1:4</p> <p><b>A</b> <b>B</b> <b>D</b></p>	<p><b>Tipo</b> <b>8</b> → <b>1 mm</b> <b>2.1 mm</b> <b>3 mm</b> <b>6.3 mm</b></p>  <p><math>i =</math> <math>i =</math></p> <p>1:1 1:1.5 1:2 1:3 1:4</p> <p><b>A</b> <b>C</b> <b>D</b></p>
<p><b>Tipo</b> <b>9</b> → <b>1 mm</b> <b>2.1 mm</b> <b>3 mm</b> <b>6.4 mm</b></p>  <p><math>i =</math> <math>i =</math></p> <p>1:1 1:1.5 1:2 1:3 1:4</p> <p><b>A</b> <b>B</b> <b>D</b> <b>C</b></p>	<p><b>Tipo</b> <b>10</b> → <b>1 mm</b> <b>2.1 mm</b> <b>3 mm</b> <b>6.5 mm</b></p>  <p><math>i =</math> <math>i =</math></p> <p>1:1 1:1.5 1:2 1:3 1:4</p> <p><b>A</b> <b>B</b> <b>D</b> <b>C</b></p>





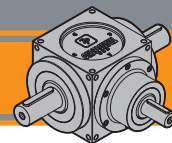

## Forme costruttive

## Constructive forms

<p><b>Tipo</b> <b>11</b> → <b>1 mm</b> <b>2.2 mm</b> <b>6.1 mm</b></p> <p><b>i=</b> <b>i=</b></p> <p>1:1 1:1.5 1:2 1:3 1:4</p> <p><b>A</b> <b>B</b> <b>C</b></p>	<p><b>Tipo</b> <b>12</b> → <b>1 mm</b> <b>2.2 mm</b> <b>6.2 mm</b></p> <p><b>i=</b> <b>i=</b></p> <p>1:1 1:1.5 1:2 1:3 1:4</p> <p><b>A</b> <b>B</b></p>
<p><b>Tipo</b> <b>13</b> → <b>1 mm</b> <b>2.2 mm</b> <b>6.3 mm</b></p> <p><b>i=</b> <b>i=</b></p> <p>1:1 1:1.5 1:2 1:3 1:4</p> <p><b>A</b> <b>C</b></p>	<p><b>Tipo</b> <b>14</b> → <b>1 mm</b> <b>2.2 mm</b> <b>6.4 mm</b></p> <p><b>i=</b> <b>i=</b></p> <p>1:1 1:1.5 1:2 1:3 1:4</p> <p><b>A</b> <b>B</b> <b>C</b></p>
<p><b>Tipo</b> <b>15</b> → <b>1 mm</b> <b>2.2 mm</b> <b>6.5 mm</b></p> <p><b>i=</b> <b>i=</b></p> <p>1:1 1:1.5 1:2 1:3 1:4</p> <p><b>A</b> <b>B</b> <b>C</b></p>	<p><b>Tipo</b> <b>16</b> → <b>1 mm</b> <b>2.2 mm</b> <b>3 mm</b> <b>6.1 mm</b></p> <p><b>i=</b> <b>i=</b></p> <p>1:1 1:1.5 1:2 1:3 1:4</p> <p><b>A</b> <b>B</b> <b>D</b> <b>C</b></p>
<p><b>Tipo</b> <b>17</b> → <b>1 mm</b> <b>2.2 mm</b> <b>3 mm</b> <b>6.2 mm</b></p> <p><b>i=</b> <b>i=</b></p> <p>1:1 1:1.5 1:2 1:3 1:4</p> <p><b>A</b> <b>B</b> <b>D</b></p>	<p><b>Tipo</b> <b>18</b> → <b>1 mm</b> <b>2.2 mm</b> <b>3 mm</b> <b>6.3 mm</b></p> <p><b>i=</b> <b>i=</b></p> <p>1:1 1:1.5 1:2 1:3 1:4</p> <p><b>A</b> <b>C</b> <b>D</b></p>
<p><b>Tipo</b> <b>19</b> → <b>1 mm</b> <b>2.2 mm</b> <b>3 mm</b> <b>6.4 mm</b></p> <p><b>i=</b> <b>i=</b></p> <p>1:1 1:1.5 1:2 1:3 1:4</p> <p><b>A</b> <b>B</b> <b>D</b> <b>C</b></p>	<p><b>Tipo</b> <b>20</b> → <b>1 mm</b> <b>2.2 mm</b> <b>3 mm</b> <b>6.5 mm</b></p> <p><b>i=</b> <b>i=</b></p> <p>1:1 1:1.5 1:2 1:3 1:4</p> <p><b>A</b> <b>B</b> <b>D</b> <b>C</b></p>

**X.X mm** → **E26**  
**E57**

**QB**

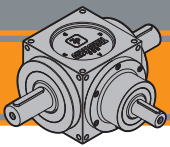

# QB Rinvii angolari Right-angle bevel gearboxes

## Forme costruttive

## Constructive forms

Tipo  
Type **21**

→ **1 mm** **2.1 mm** **6.6 mm**

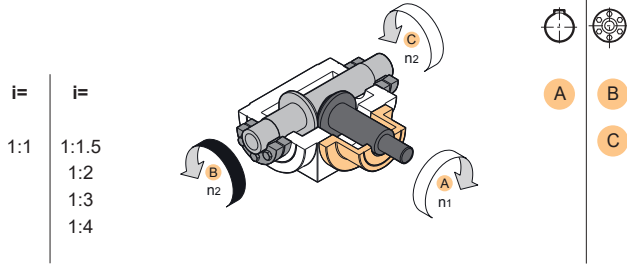

Tipo  
Type **22**

→ **1 mm** **2.1 mm** **3 mm** **6.6 mm**

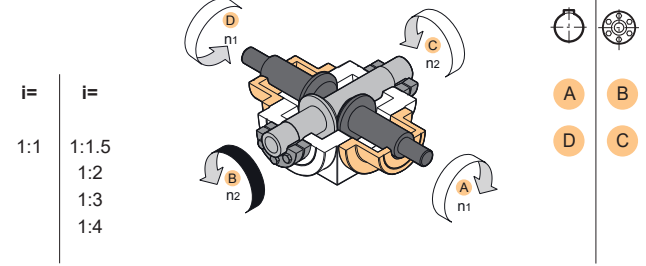

Tipo  
Type **23**

→ **1 mm** **2.2 mm** **6.6 mm**

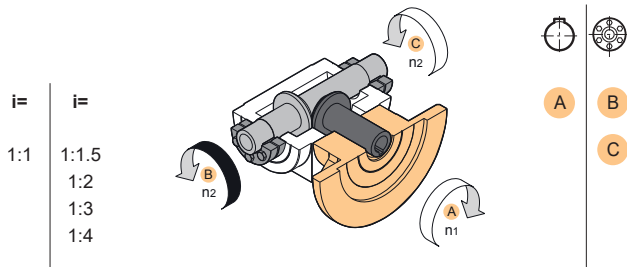

Tipo  
Type **24**

→ **1 mm** **2.2 mm** **3 mm** **6.6 mm**

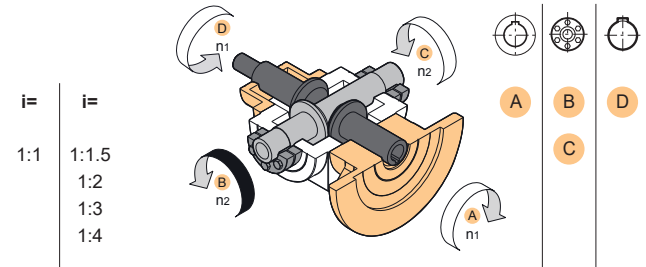

Tipo  
Type **25** **26** **27**

→ **1 mm** **2.1 mm** **7.2 mm**

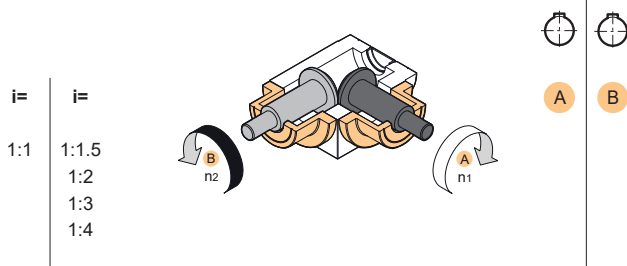

Tipo  
Type **28** **29** **30**

→ **1 mm** **2.1 mm** **7.1 mm**

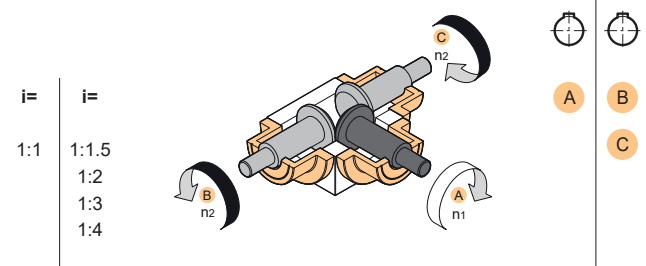

Tipo  
Type **31** **32** **33**

→ **1 mm** **2.1 mm** **3 mm** **7.1 mm**

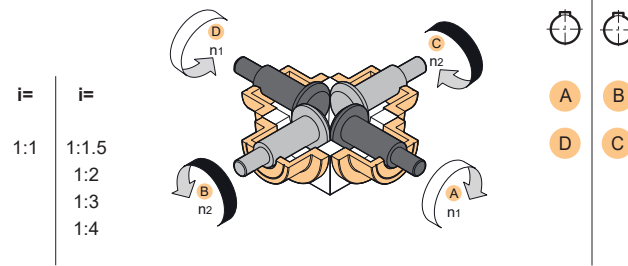

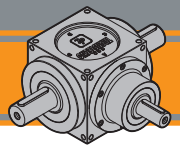

## Forme costruttive

## Constructive forms

**Tipo** **34** → **1 mm** **2.1 mm** **4 mm** **6.4 mm**

**i=**  
1:1.5  
1:2  
1:3  
1:4

**A** **B**  
**E** **C**

**Tipo** **35** → **1 mm** **2.1 mm** **4 mm** **6.5 mm**

**i=**  
1:1.5  
1:2  
1:3  
1:4

**A** **B**  
**E** **C**

**Tipo** **36** → **1 mm** **2.1 mm** **3 mm** **4 mm** **6.4 mm**

**i=**  
1:1.5  
1:2  
1:3  
1:4

**A** **B**  
**D** **C**  
**E**

**Tipo** **37** → **1 mm** **2.1 mm** **3 mm** **4 mm** **6.5 mm**

**i=**  
1:1.5  
1:2  
1:3  
1:4

**A** **B**  
**D** **C**  
**E**

**Tipo** **38** → **1 mm** **2.1 mm** **3 mm** **4 mm** **5 mm** **6.4 mm**

**i=**  
1:1.5  
1:2  
1:3  
1:4

**A** **B**  
**D** **C**  
**E** **F**

**Tipo** **39** → **1 mm** **2.1 mm** **3 mm** **4 mm** **5 mm** **6.5 mm**

**i=**  
1:1.5  
1:2  
1:3  
1:4

**A** **B**  
**D** **C**  
**E** **F**

**Tipo** **40** → **1 mm** **2.1 mm** **4 mm** **6.1 mm**

**i=**  
1:1.5  
1:2  
1:3  
1:4

**A** **B**  
**E** **C**

**Tipo** **41** → **1 mm** **2.1 mm** **4 mm** **6.2 mm**

**i=**  
1:1.5  
1:2  
1:3  
1:4

**A** **B**  
**E**



**QB**

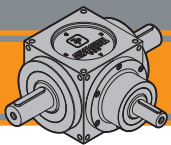

# QB Rinvii angolari Right-angle bevel gearboxes

## Forme costruttive

## Constructive forms

Tipo  
Type **42**

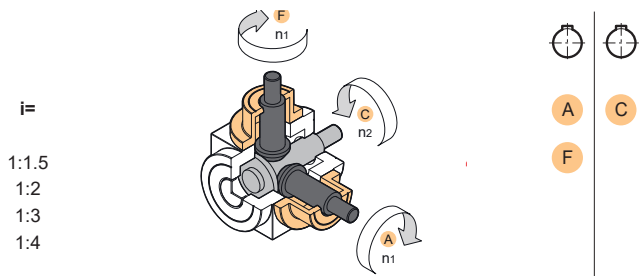

Tipo  
Type **43**

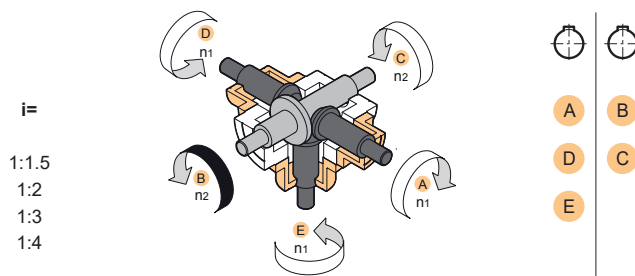

Tipo  
Type **44**

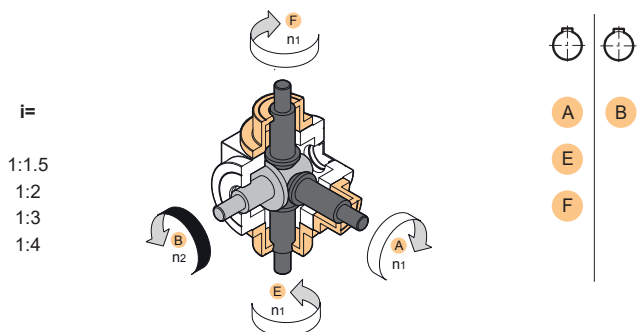

Tipo  
Type **45**

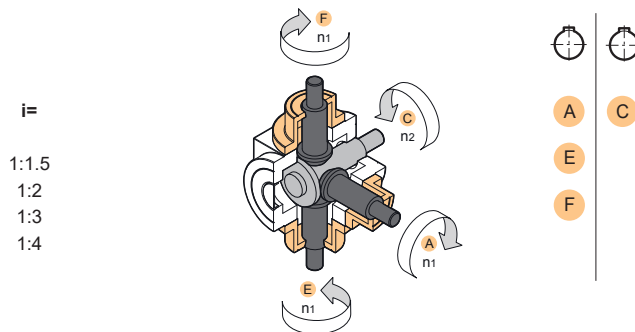

Tipo  
Type **46**

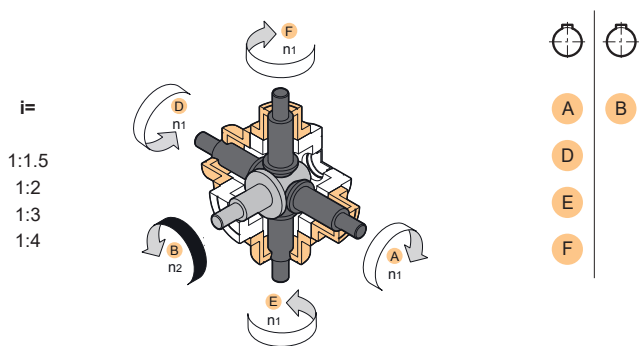

Tipo  
Type **47**

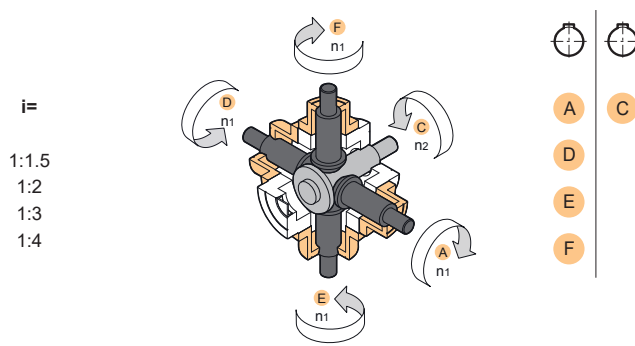

Tipo  
Type **48**

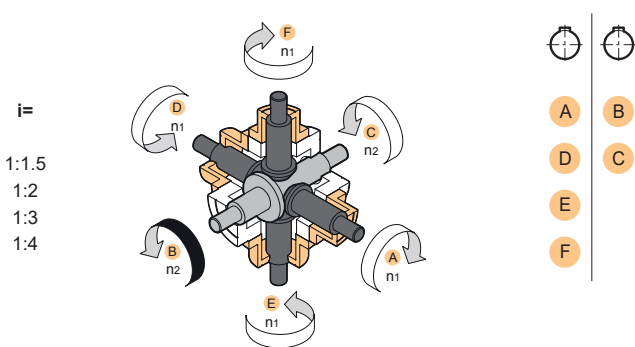

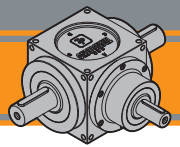

### Forme costruttive

### Constructive forms

Tipo 49 → 1 mm, 2.1 mm, 7.1 mm

Moltiplica  
Speed Multiplier

$i =$

- 1.5:1
- 2:1
- 3:1
- 4:1

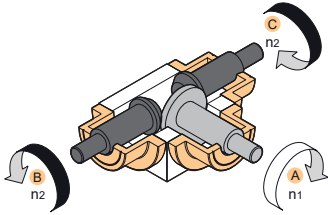

Tipo 50 → 1 mm, 2.1 mm, 3 mm, 7.2 mm

Moltiplica  
Speed Multiplier

(\*) Forma costruttiva simile alla 28 / 29 / 30.  
This type similar to type 28-29-30

$i =$

- 1.5:1
- 2:1
- 3:1
- 4:1

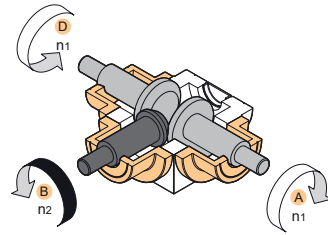

Tipo 51 → 1 mm, 2.1 mm, 4 mm, 7.2 mm

Moltiplica  
Speed Multiplier

$i =$

- 1.5:1
- 2:1
- 3:1
- 4:1

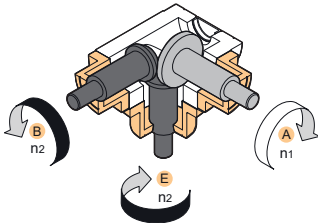

Tipo 52 → 1 mm, 2.1 mm, 4 mm, 5 mm, 7.2 mm

Moltiplica  
Speed Multiplier

$i =$

- 1.5:1
- 2:1
- 3:1
- 4:1

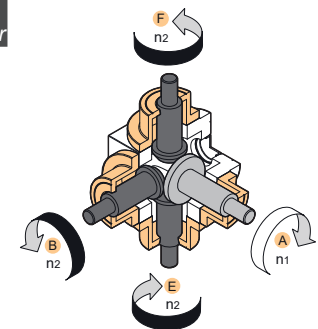

Tipo 53 → 1 mm, 2.1 mm, 4 mm, 5 mm, 7.1 mm

Moltiplica  
Speed Multiplier

$i =$

- 1.5:1
- 2:1
- 3:1
- 4:1

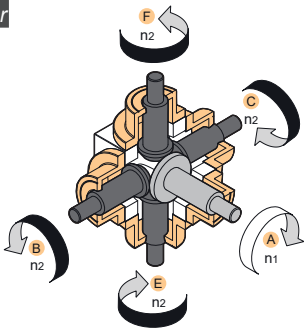

Tipo 54 → 1 mm, 2.1 mm, 3 mm, 4 mm, 5 mm, 7.2 mm

Moltiplica  
Speed Multiplier

$i =$

- 1.5:1
- 2:1
- 3:1
- 4:1

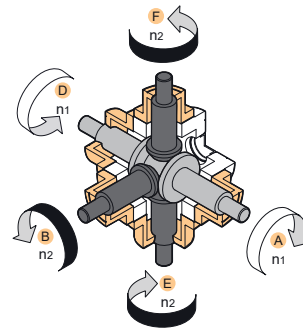

Tipo 55 → 1 mm, 2.1 mm, 3 mm, 4 mm, 5 mm, 7.1 mm

Moltiplica  
Speed Multiplier

$i =$

- 1.5:1
- 2:1
- 3:1
- 4:1

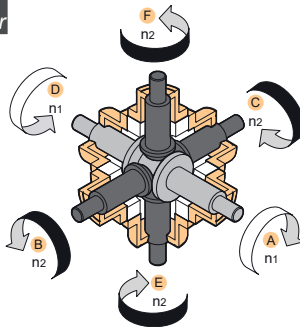

X.X mm → E26, E57

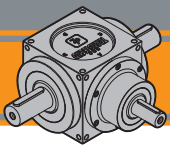

# QB Rinvii angolari Right-angle bevel gearboxes

## Forme costruttive

## Constructive forms

Tipo 56 → 1 mm 2.2 mm 7.2 mm

$i =$   
1:1  
1:1.5  
1:2  
1:3  
1:4

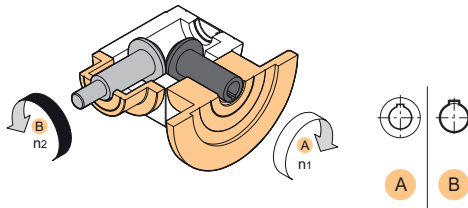

Tipo 57 → 1 mm 2.2 mm 7.1 mm

$i =$   
1:1  
1:1.5  
1:2  
1:3  
1:4

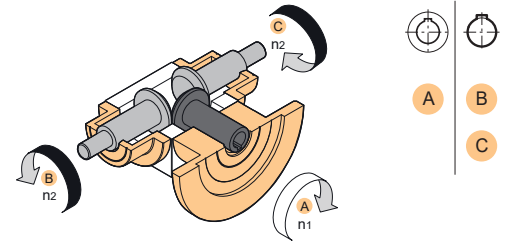

Tipo 58 → 1 mm 2.2 mm 3 mm 7.2 mm

$i =$   
1:1  
1:1.5  
1:2  
1:3  
1:4

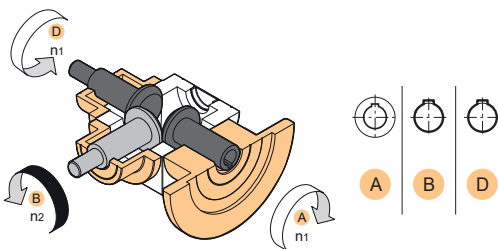

Tipo 59 → 1 mm 2.2 mm 3 mm 7.1 mm

$i =$   
1:1  
1:1.5  
1:2  
1:3  
1:4

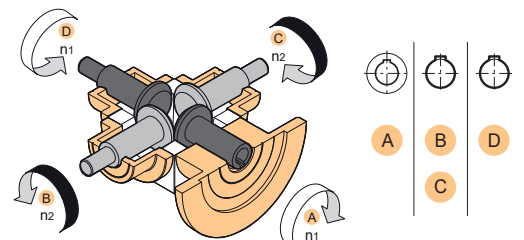

Tipo 60 → 1 mm 2.2 mm 5 mm 6.4 mm

$i =$   
1:1.5  
1:2  
1:3  
1:4

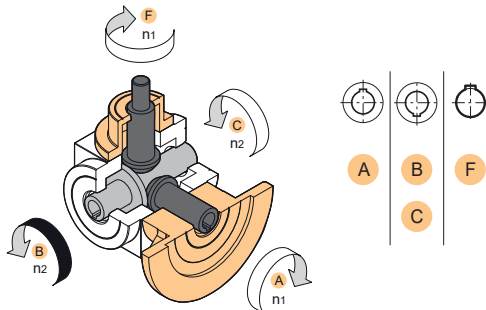

Tipo 61 → 1 mm 2.2 mm 4 mm 5 mm 6.4 mm

$i =$   
1:1.5  
1:2  
1:3  
1:4

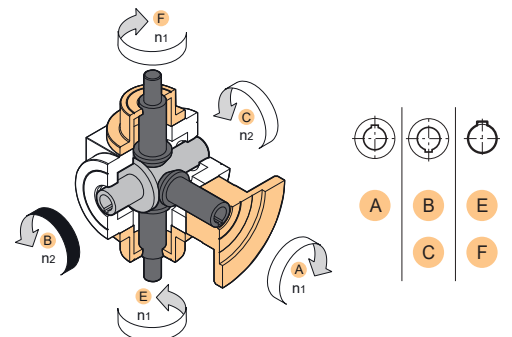

Tipo 62 → 1 mm 2.2 mm 4 mm 6.1 mm

$i =$   
1:1.5  
1:2  
1:3  
1:4

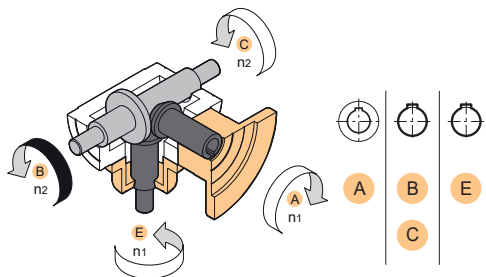

Tipo 63 → 1 mm 2.2 mm 4 mm 5 mm 7.2 mm

Moltiplica  
Speed Multiplier

$i =$   
1.5:1  
2:1  
3:1  
4:1

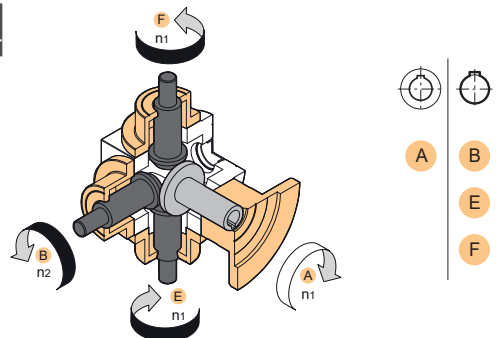

X.X mm → E26 E57

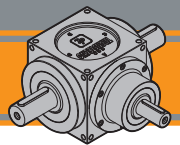

### Forme costruttive

### Constructive forms

**Tipo** 64 → **1 mm** **2.2 mm** **4 mm** **6.4 mm**

**Type**

$i=$   
1:1.5  
1:2  
1:3  
1:4

A B E  
C

**Tipo** 65 → **1 mm** **2.2 mm** **3 mm** **4 mm** **5 mm** **6.4 mm**

**Type**

$i=$   
1:1.5  
1:2  
1:3  
1:4

A B D  
C E F

**Tipo** 66 → **1 mm** **2.2 mm** **3 mm** **4 mm** **6.4 mm**

**Type**

$i=$   
1:1.5  
1:2  
1:3  
1:4

A B D  
C E

**Tipo** 67 → **1 mm** **2.2 mm** **5 mm** **6.3 mm**

**Type**

$i=$   
1:1.5  
1:2  
1:3  
1:4

A C F

**Tipo** 68 → **1 mm** **2.2 mm** **5 mm** **6.2 mm**

**Type**

$i=$   
1:1.5  
1:2  
1:3  
1:4

A B F

QB



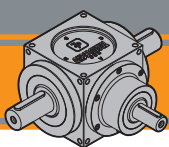

# QB Rinvii angolari Right-angle bevel gearboxes

## Dimensioni

## Dimensions

### QB 54

#### Carter

#### Casing

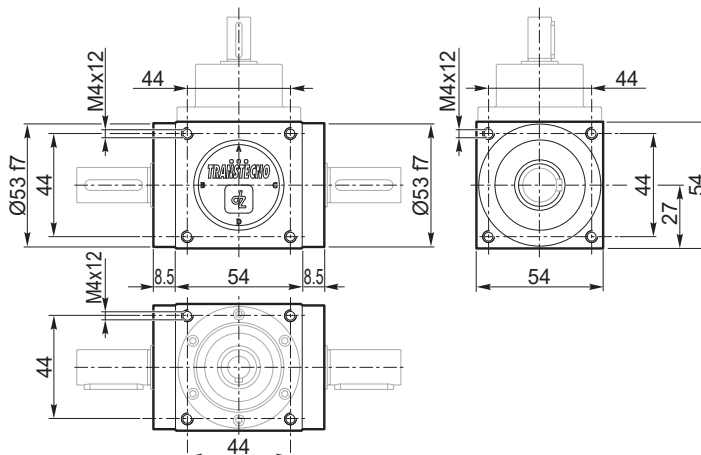
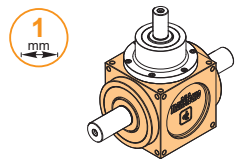

Forma costruttiva  
Constructive forms

dalla 1 alla 68 - from 1 to 68

#### Torretta A

#### Bell housing A

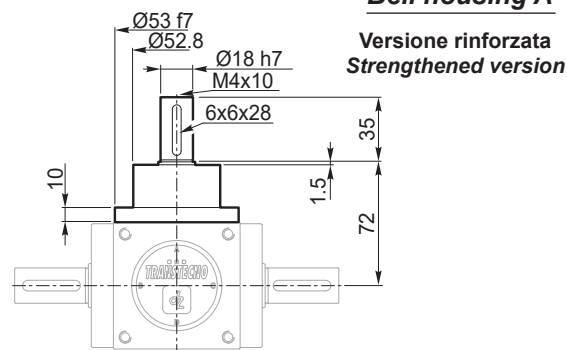
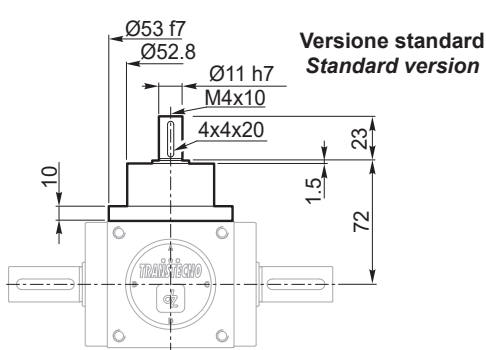
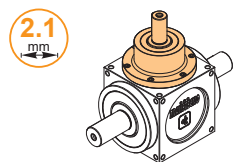

Forma costruttiva Constructive forms	1	2	3	4	5	6	7	8	9	10	21	22	25	26	27	28	29	30	31	32	33	34	35	36	37	38	39	40	41	42	43	44	45	46	47	48	49	50	51	52	53	54	55						
Versione standard Standard version																																																	
Versione rinforzata Strengthened version																																																	

Disponibile / Available

#### Versione PAM Input flange version

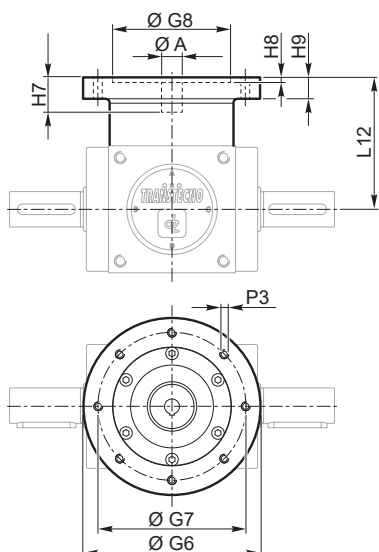
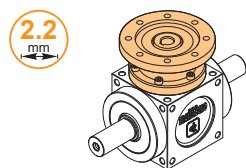

Flangia Flange	Ø A	G6	G7	G8	L12	H5	H6	H7	H8	H9	P3
Non disponibile / Not available											

Forma costruttiva  
Constructive forms



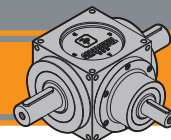

Dimensioni

Dimensions

QB 54

Torretta D

Bell housing D

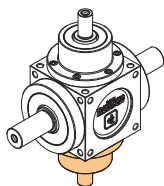

Versione standard  
Standard version

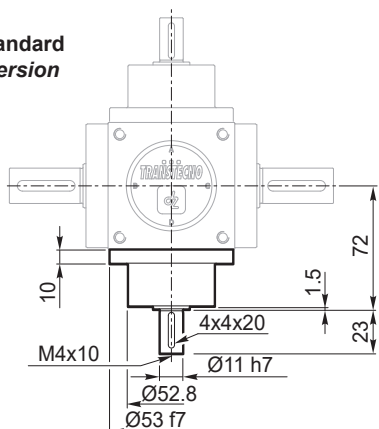

Versione rinforzata  
Strengthened version

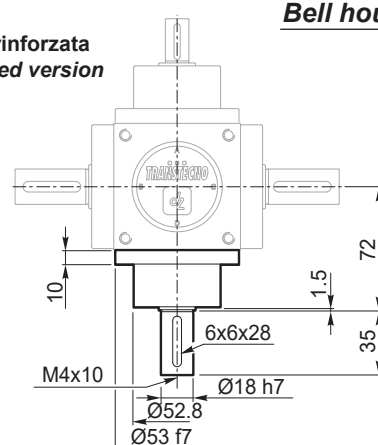

Il diametro della presa di forza della torretta D è sempre uguale al diametro della presa di forza della torretta A versione standard o rinforzata  
The diameter of the power take-off of bell housing D is always the same as the diameter of the power take-off of bell housing A standard or strengthened version

Forma costruttiva Constructive forms	6	7	8	9	10	16	17	18	19	20	22	24	31	32	33	36	37	38	39	43	46	47	48	50	54	55	58	59	65	66	
Versione standard Standard version																															
Versione rinforzata Strengthened version																															

Disponibile / Available

Torretta E

Bell housing E

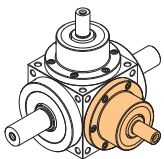

Versione standard  
Standard version

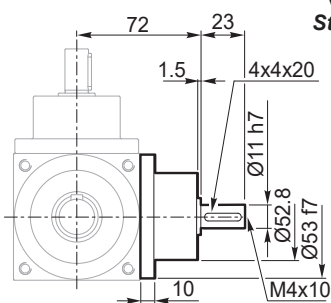

Versione rinforzata  
Strengthened version

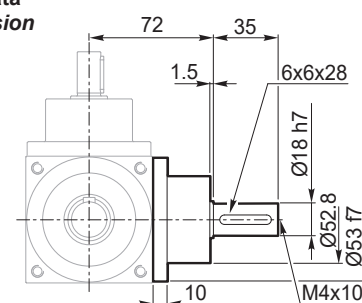

Il diametro della presa di forza della torretta E è sempre uguale al diametro della presa di forza della torretta A versione standard o rinforzata  
The diameter of the power take-off of bell housing E is always the same as the diameter of the power take-off of bell housing A standard or strengthened version

Forma costruttiva Constructive forms	34	35	36	37	38	39	40	41	43	44	45	46	47	48	51	52	53	54	55	61	62	63	64	65	66	
Versione standard Standard version																										
Versione rinforzata Strengthened version																										

Torretta F

Bell housing F

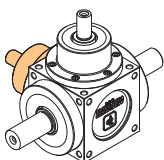

Versione standard  
Standard version

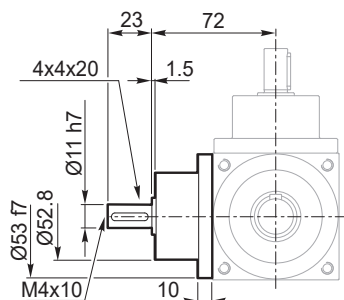

Versione rinforzata  
Strengthened version

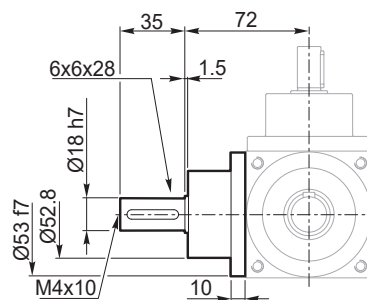

Il diametro della presa di forza della torretta F è sempre uguale al diametro della presa di forza della torretta A versione standard o rinforzata  
The diameter of the power take-off of bell housing F is always the same as the diameter of the power take-off of bell housing A standard or strengthened version

Forma costruttiva Constructive forms	38	39	42	44	45	46	47	48	52	53	54	55	60	61	63	65	66	67
Versione standard Standard version																		
Versione rinforzata Strengthened version																		



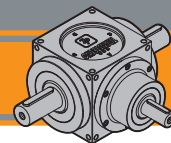

Dimensioni

Dimensions

QB 54

Asse B-C con Torrette

Axis B-C with bell housing

Torrette B-C  
Bell Housings B-C

7.1  
mm

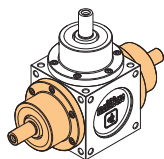

Versione standard  
Standard version

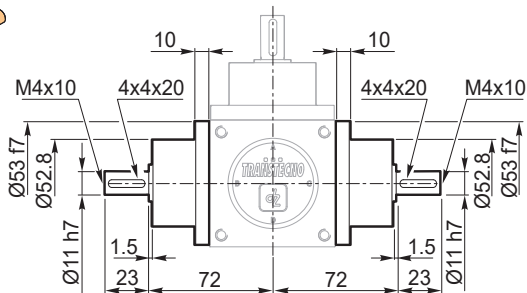

Versione rinforzata  
Strengthened version

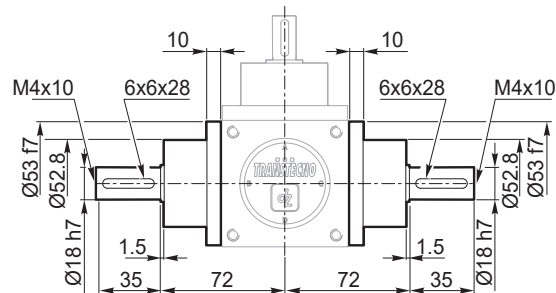

Forma costruttiva Constructive forms	28	29	30	31	32	33	49	53	55	57	59																			
Versione standard Standard version																														
Versione rinforzata Strengthened version																														

Disponibile / Available

Torretta B  
Bell housing B

7.2  
mm

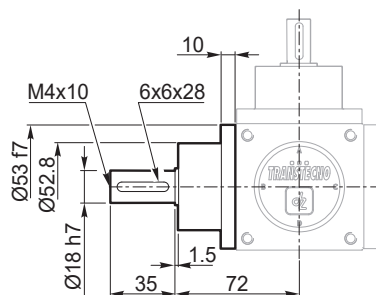
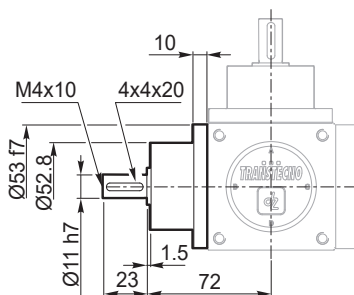
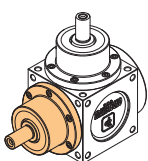

Forma costruttiva Constructive forms	25	26	27	50	51	52	54	56	58	63																			
Versione standard Standard version																													
Versione rinforzata Strengthened version																													

Disponibile / Available

Torretta C  
Bell housing C

7.3  
mm

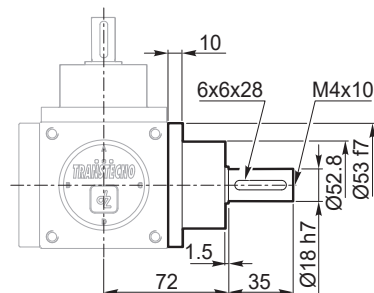
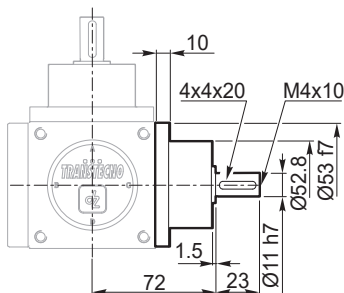
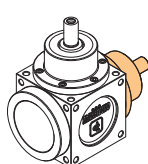

Forma costruttiva Constructive forms																													
Versione standard Standard version																													
Versione rinforzata Strengthened version																													

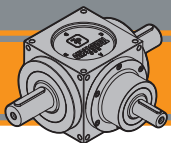

# QB Rinvii angolari Right-angle bevel gearboxes

Dimensioni

Dimensions

## QB 86

Carter

Casing

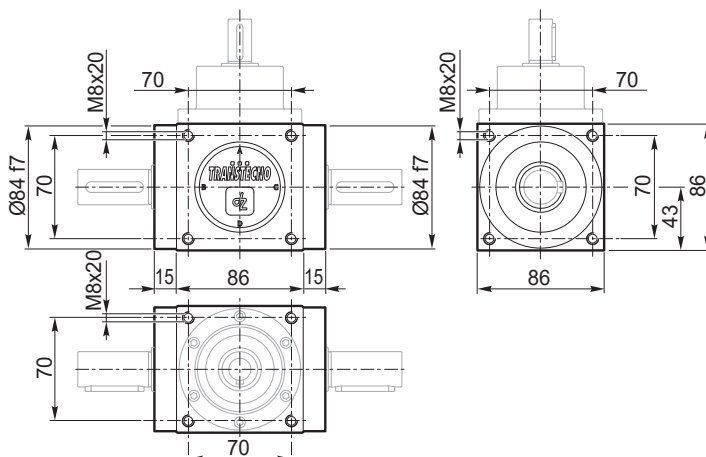
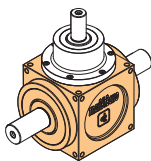

Forma costruttiva / Constructive forms: dalla 1 alla 68 - from 1 to 68

Torretta A

Bell housing A

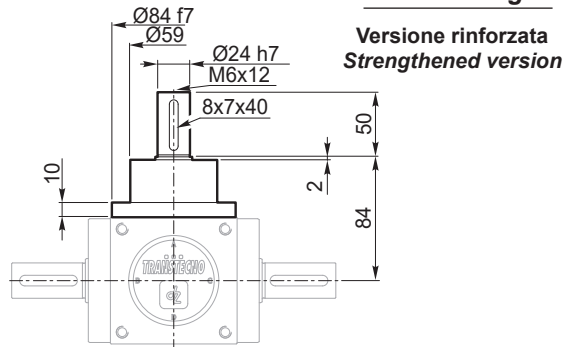
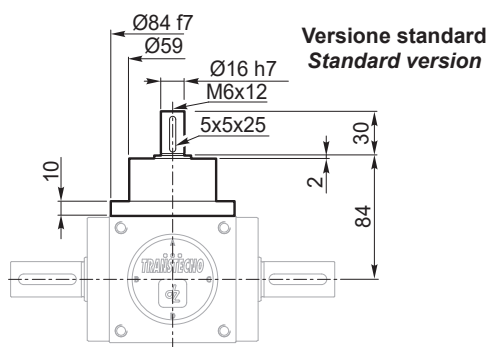
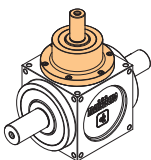

Forma costruttiva / Constructive forms	1	2	3	4	5	6	7	8	9	10	21	22	25	26	27	28	29	30	31	32	33	34	35	36	37	38	39	40	41	42	43	44	45	46	47	48	49	50	51	52	53	54	55						
Versione standard / Standard version																																																	
Versione rinforzata / Strengthened version																																																	

Disponibile / Available

**Versione PAM  
Input flange version**

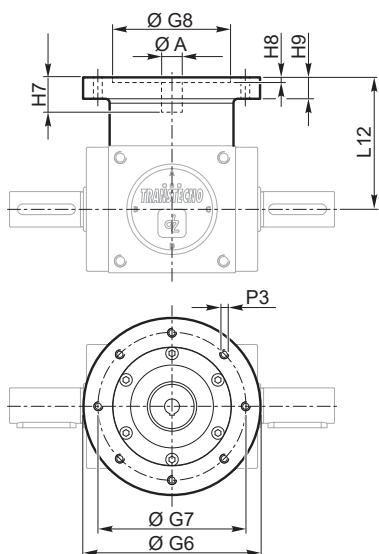
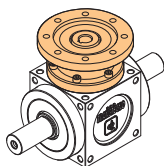

Flangia / Flange	ØA H7	G6	G7	G8	L12	H5	H6	H7	H8	H9	P3
56 B5	9	120	100	80	90	10.4	3	23	4	11	M6
63 B5	11	140	115	95	90	12.8	4	23	4	11	M8
71 B5	14	160	130	110	90	16.3	5	30	4	11	M8
71 B14	14	105	85	70	90	16.3	5	30	4	10	7
80 B5	19	200	165	130	100	21.8	6	40	5	11	M10
80B14	19	120	100	80	100	21.8	6	40	5	11	7

Forma costruttiva / Constructive forms	11	12	13	14	15	16	17	18	19	20	23	24	56	57	58	59	60	61	62	63	64	65	66	67	68
--	----	----	----	----	----	----	----	----	----	----	----	----	----	----	----	----	----	----	----	----	----	----	----	----	----

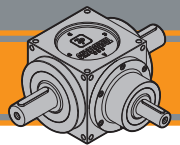

Dimensioni

Dimensions

**QB 86**

**Torretta D**

**Bell housing D**

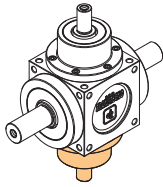

**Versione standard**  
Standard version

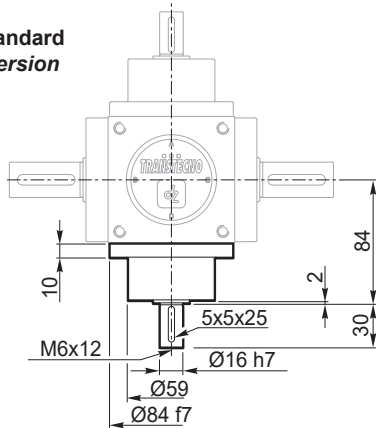

**Versione rinforzata**  
Strengthened version

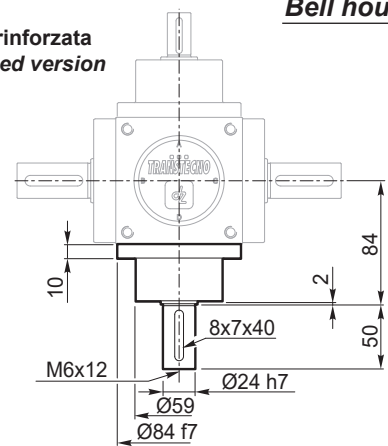

Il diametro della presa di forza della torretta D è sempre uguale al diametro della presa di forza della torretta A versione standard o rinforzata  
The diameter of the power take-off of bell housing D is always the same as the diameter of the power take-off of bell housing A standard or strengthened version

<b>Forma costruttiva</b> Constructive forms	6	7	8	9	10	16	17	18	19	20	22	24	31	32	33	36	37	38	39	43	46	47	48	50	54	55	58	59	65	66	
<b>Versione standard</b> Standard version																															
<b>Versione rinforzata</b> Strengthened version																															

Disponibile / Available

**Torretta E**

**Bell housing E**

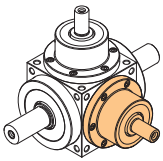

**Versione standard**  
Standard version

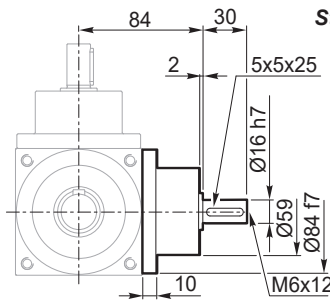

**Versione rinforzata**  
Strengthened version

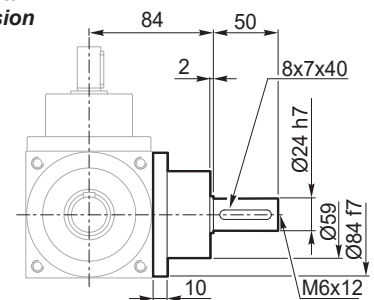

Il diametro della presa di forza della torretta E è sempre uguale al diametro della presa di forza della torretta A versione standard o rinforzata  
The diameter of the power take-off of bell housing E is always the same as the diameter of the power take-off of bell housing A standard or strengthened version

<b>Forma costruttiva</b> Constructive forms	34	35	36	37	38	39	40	41	43	44	45	46	47	48	51	52	53	54	55	61	62	63	64	65	66	
<b>Versione standard</b> Standard version																										
<b>Versione rinforzata</b> Strengthened version																										

**Torretta F**

**Bell housing F**

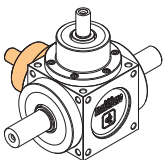

**Versione standard**  
Standard version

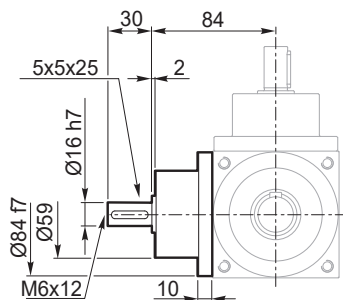

**Versione rinforzata**  
Strengthened version

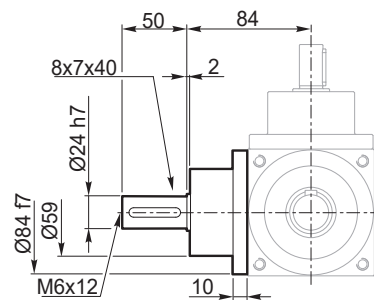

Il diametro della presa di forza della torretta F è sempre uguale al diametro della presa di forza della torretta A versione standard o rinforzata  
The diameter of the power take-off of bell housing F is always the same as the diameter of the power take-off of bell housing A standard or strengthened version

<b>Forma costruttiva</b> Constructive forms	38	39	42	44	45	46	47	48	52	53	54	55	60	61	63	65	66	67
<b>Versione standard</b> Standard version																		
<b>Versione rinforzata</b> Strengthened version																		

QB

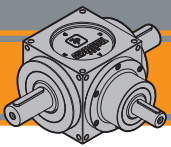

# QB Rinvii angolari Right-angle bevel gearboxes

**Dimensioni**

**Dimensions**

## QB 86

**Asse B-C integrale**

**B-C single output axis**

Sporgente B-C  
Protruding B-C

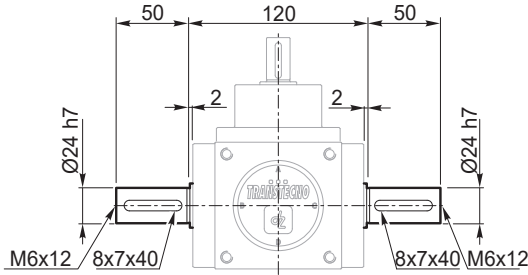
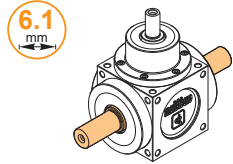

Forma costruttiva	Constructive forms	1	6	11	16	40	43	48	62										
-------------------	--------------------	---	---	----	----	----	----	----	----	--	--	--	--	--	--	--	--	--	--

Sporgente B  
Protruding B

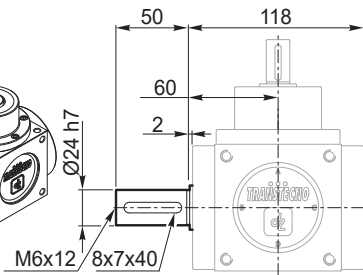
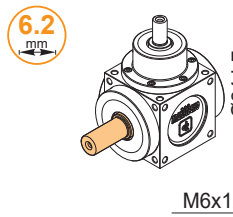

Forma costruttiva	Constructive forms	2	7	12	17	41	44	46	68
-------------------	--------------------	---	---	----	----	----	----	----	----

Sporgente C  
Protruding C

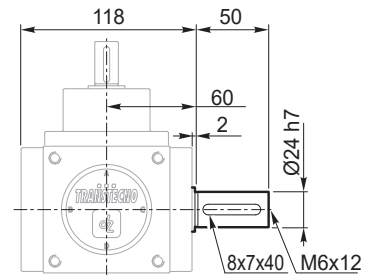
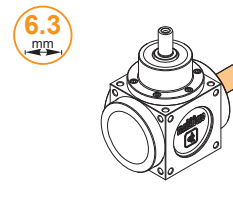

Forma costruttiva	Constructive forms	3	8	13	18	42	45	47	67
-------------------	--------------------	---	---	----	----	----	----	----	----

Albero cavo con linguetta  
Hollow shaft with key

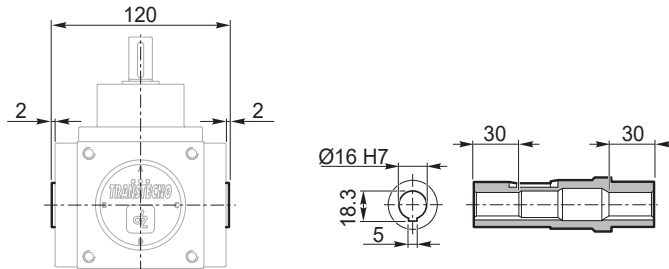
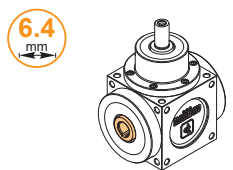

Forma costruttiva	Constructive forms	4	9	14	19	34	36	38	60	61	64	65	66
-------------------	--------------------	---	---	----	----	----	----	----	----	----	----	----	----

Albero cavo scanalato UNI 8953  
Grooved hollow shaft UNI 8953

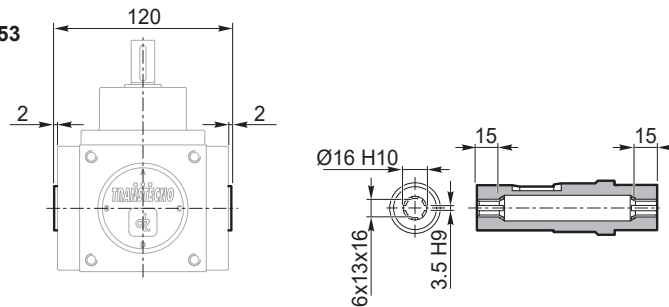
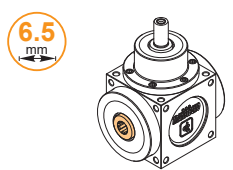

Forma costruttiva	Constructive forms	5	10	15	20	35	37	39
-------------------	--------------------	---	----	----	----	----	----	----

Albero cavo con calettatore  
Hollow shaft with shrink disc

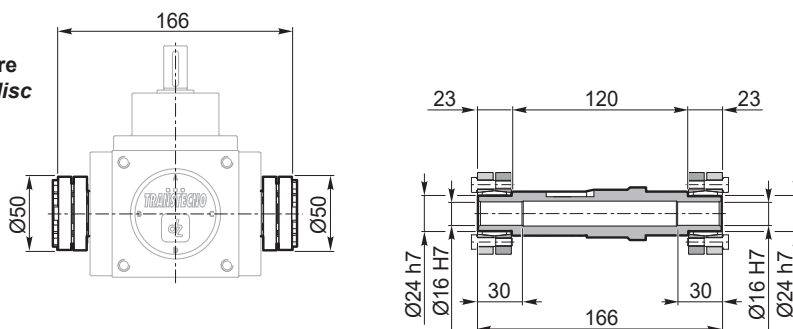

Forma costruttiva	Constructive forms	21	22	23	24														
-------------------	--------------------	----	----	----	----	--	--	--	--	--	--	--	--	--	--	--	--	--	--

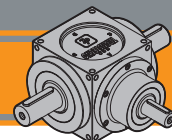

Dimensioni

Dimensions

**QB 86**

**Asse B-C con Torrette**

**Axis B-C with bell housing**

Torrette B-C  
Bell Housings B-C

7.1  
mm

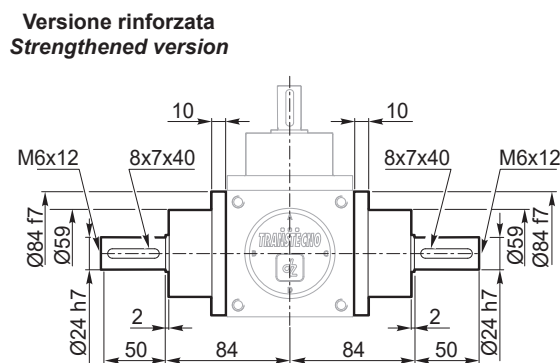
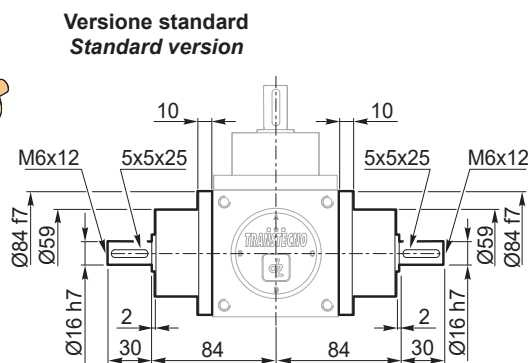
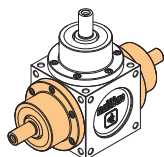

Forma costruttiva Constructive forms	28	29	30	31	32	33	49	53	55	57	59										
Versione standard Standard version																					
Versione rinforzata Strengthened version																					

Disponibile / Available

Torretta B  
Bell housing B

7.2  
mm

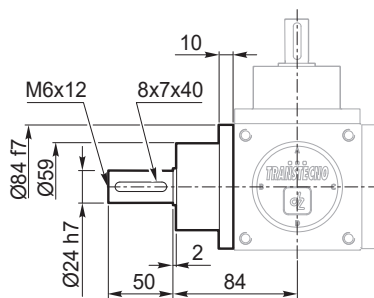
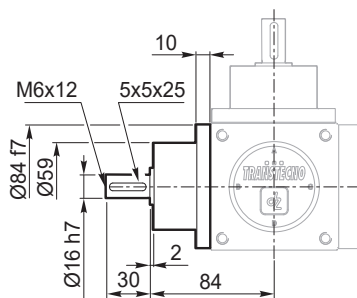
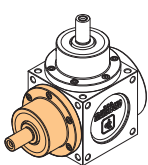

Forma costruttiva Constructive forms	25	26	27	50	51	52	54	56	58	63											
Versione standard Standard version																					
Versione rinforzata Strengthened version																					

Disponibile / Available

Torretta C  
Bell housing C

7.3  
mm

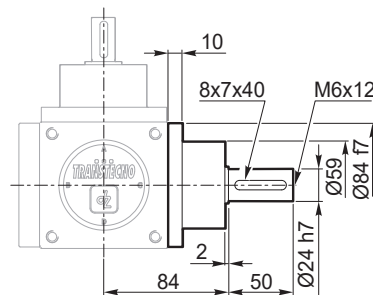
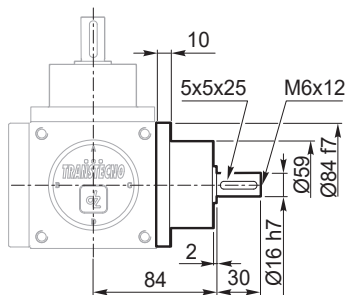
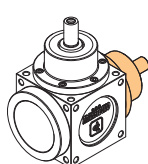

Forma costruttiva Constructive forms																					
Versione standard Standard version																					
Versione rinforzata Strengthened version																					

QB

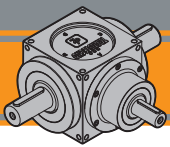

# QB Rinvii angolari Right-angle bevel gearboxes

Dimensioni

Dimensions

## QB 110

Carter

Casing

1  
mm

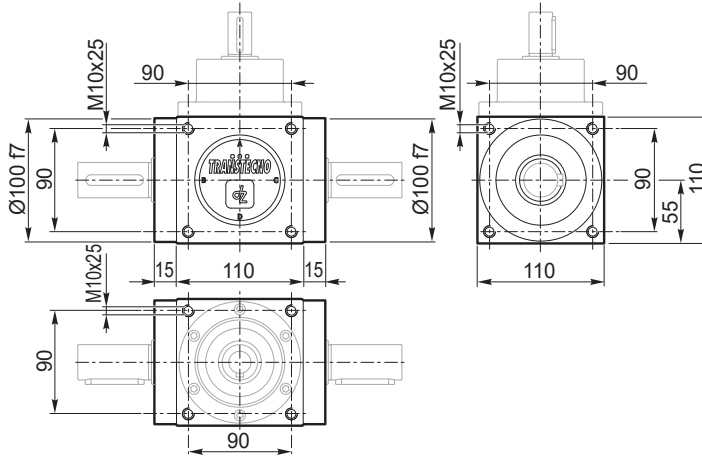
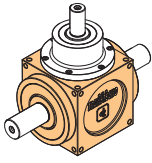

Forma costruttiva / Constructive forms dalla 1 alla 68 - from 1 to 68

Torretta A

Bell housing A

2.1  
mm

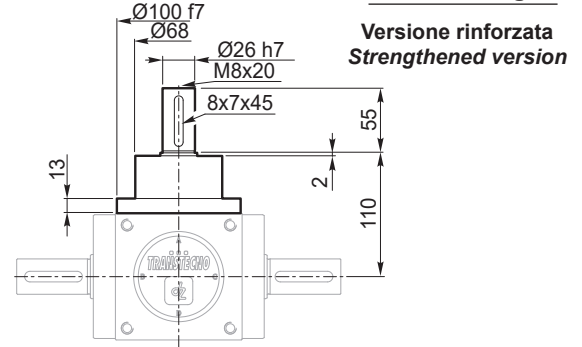
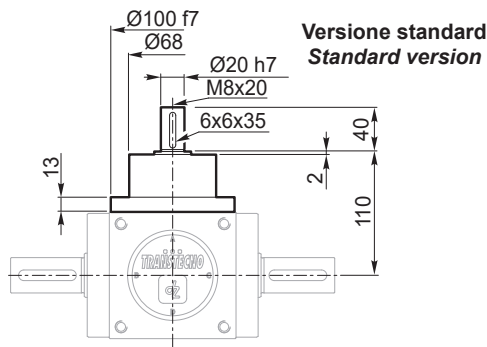
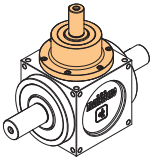

Forma costruttiva / Constructive forms	1	2	3	4	5	6	7	8	9	10	21	22	25	26	27	28	29	30	31	32	33	34	35	36	37	38	39	40	41	42	43	44	45	46	47	48	49	50	51	52	53	54	55							
Versione standard / Standard version																																																		
Versione rinforzata / Strengthened version																																																		

Disponibile / Available

Versione PAM  
Input flange version

2.2  
mm

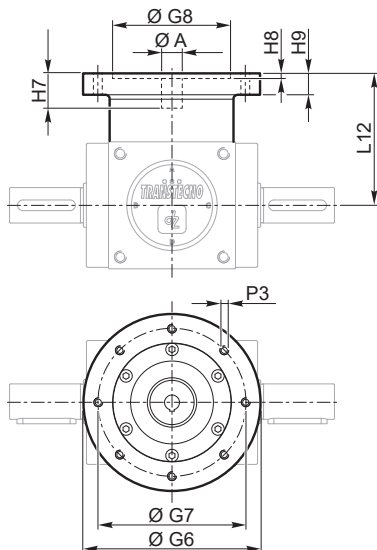
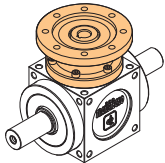

Flangia / Flange	ØA H7	G6	G7	G8	L12	H5	H6	H7	H8	H9	P3
63 B5	11	140	115	95	105	12.8	4	23	4	11	M8
71 B5	14	160	130	110	105	16.3	5	30	4	11	M8
71 B14	14	105	85	70	105	16.3	5	30	4	11	7
80 B5	19	200	165	130	105	21.8	6	40	5	11	M10
80B14	19	120	100	80	105	21.8	6	40	5	11	7

Forma costruttiva / Constructive forms	11	12	13	14	15	16	17	18	19	20	23	24	56	57	58	59	60	61	62	63	64	65	66	67	68
--	----	----	----	----	----	----	----	----	----	----	----	----	----	----	----	----	----	----	----	----	----	----	----	----	----



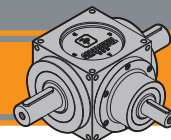

Dimensioni

Dimensions

QB 110

Torretta D

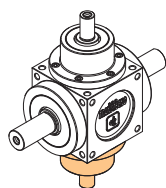

Versione standard  
Standard version

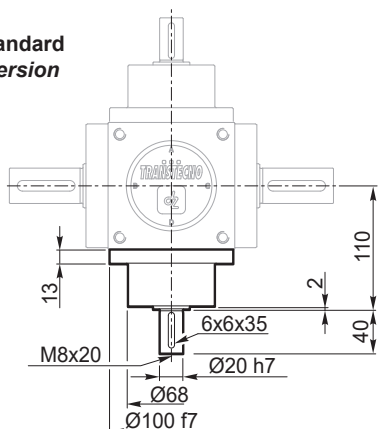

Versione rinforzata  
Strengthened version

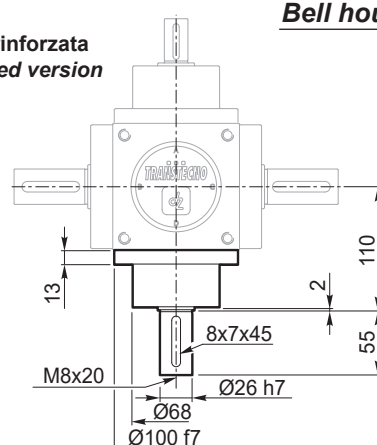

Bell housing D

Il diametro della presa di forza della torretta D è sempre uguale al diametro della presa di forza della torretta A versione standard o rinforzata  
The diameter of the power take-off of bell housing D is always the same as the diameter of the power take-off of bell housing A standard or strengthened version

Forma costruttiva Constructive forms	6	7	8	9	10	16	17	18	19	20	22	24	31	32	33	36	37	38	39	43	46	47	48	50	54	55	58	59	65	66	
Versione standard Standard version																															
Versione rinforzata Strengthened version																															

Disponibile / Available

Torretta E

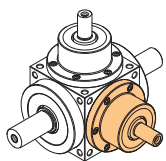

Versione standard  
Standard version

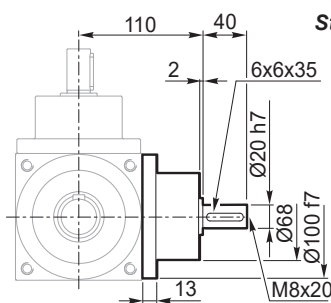

Versione rinforzata  
Strengthened version

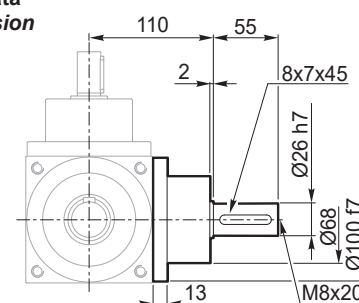

Bell housing E

Il diametro della presa di forza della torretta E è sempre uguale al diametro della presa di forza della torretta A versione standard o rinforzata  
The diameter of the power take-off of bell housing E is always the same as the diameter of the power take-off of bell housing A standard or strengthened version

Forma costruttiva Constructive forms	34	35	36	37	38	39	40	41	43	44	45	46	47	48	51	52	53	54	55	61	62	63	64	65	66	
Versione standard Standard version																										
Versione rinforzata Strengthened version																										

Torretta F

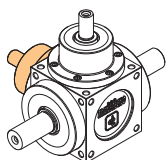

Versione standard  
Standard version

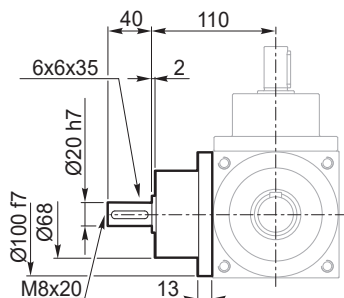

Versione rinforzata  
Strengthened version

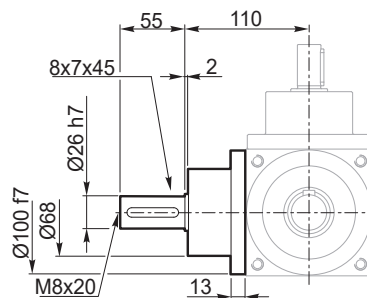

Bell housing F

Il diametro della presa di forza della torretta F è sempre uguale al diametro della presa di forza della torretta A versione standard o rinforzata  
The diameter of the power take-off of bell housing F is always the same as the diameter of the power take-off of bell housing A standard or strengthened version

Forma costruttiva Constructive forms	38	39	42	44	45	46	47	48	52	53	54	55	60	61	63	65	66	67
Versione standard Standard version																		
Versione rinforzata Strengthened version																		

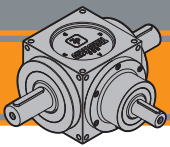

**Dimensioni**

**Dimensions**

**QB 110**

**Asse B-C integrale**

**B-C single output axis**

**Sporgente B-C**  
Protruding B-C

**6.1**  
mm

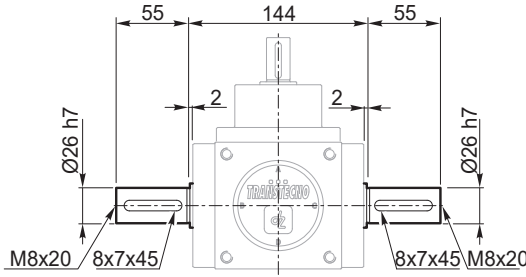
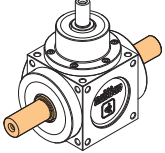

Forma costruttiva	1	6	11	16	40	43	48	62																				
Constructive forms																												

**Sporgente B**  
Protruding B

**6.2**  
mm

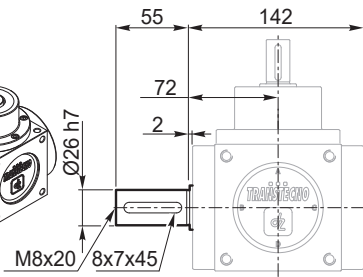
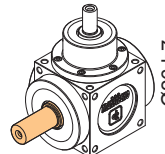

**Sporgente C**  
Protruding C

**6.3**  
mm

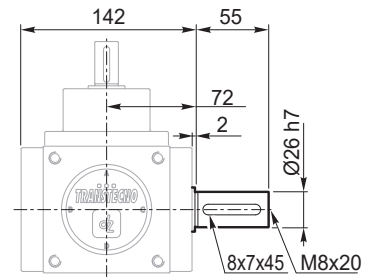
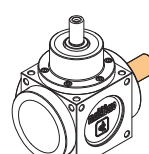

Forma costruttiva	2	7	12	17	41	44	46	68																				
Constructive forms																												

Forma costruttiva	3	8	13	18	42	45	47	67																				
Constructive forms																												

**Albero cavo con linguetta**  
Hollow shaft with key

**6.4**  
mm

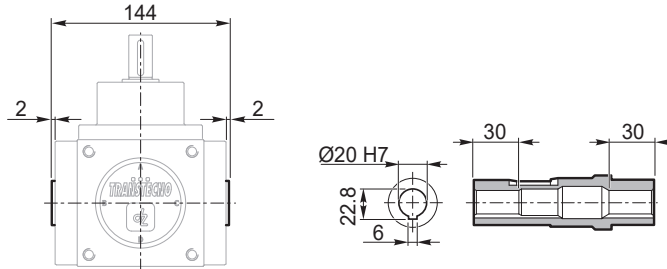
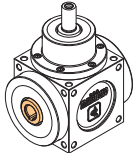

Forma costruttiva	4	9	14	19	34	36	38	60	61	64	65	66																
Constructive forms																												

**Albero cavo scanalato UNI 8953**  
Grooved hollow shaft UNI 8953

**6.5**  
mm

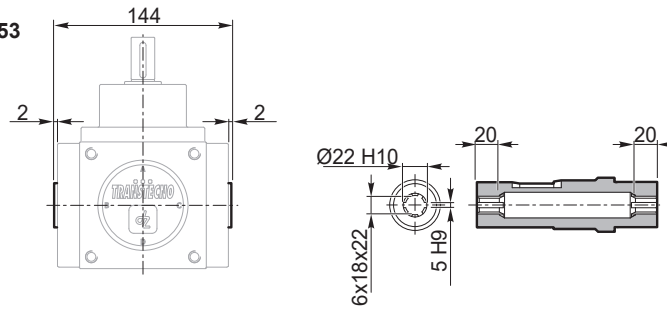
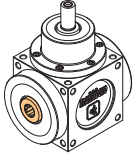

Forma costruttiva	5	10	15	20	35	37	39																					
Constructive forms																												

**Albero cavo con calettatore**  
Hollow shaft with shrink disc

**6.6**  
mm

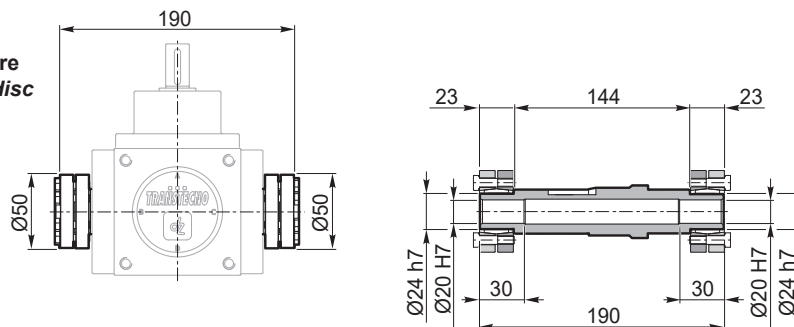
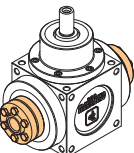

Forma costruttiva	21	22	23	24																								
Constructive forms																												

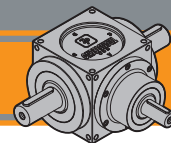

**Dimensioni**

**Dimensions**

**QB 110**

**Asse B-C con Torrette**

**Axis B-C with bell housing**

**Torrette B-C  
Bell Housings B-C**

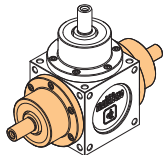

**Versione standard  
Standard version**

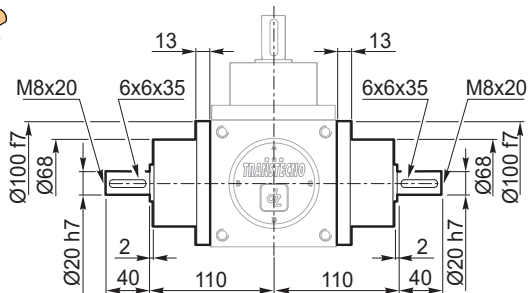

**Versione rinforzata  
Strengthened version**

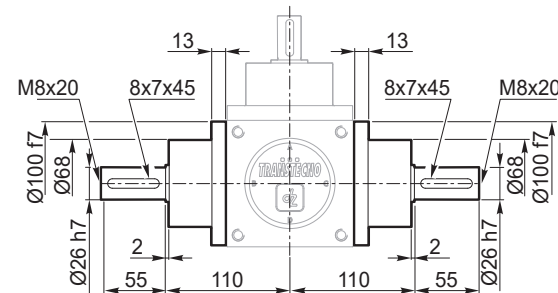

Forma costruttiva <i>Constructive forms</i>	28	29	30	31	32	33	49	53	55	57	59											
Versione standard <i>Standard version</i>																						
Versione rinforzata <i>Strengthened version</i>																						

Disponibile / Available

**Torretta B  
Bell housing B**

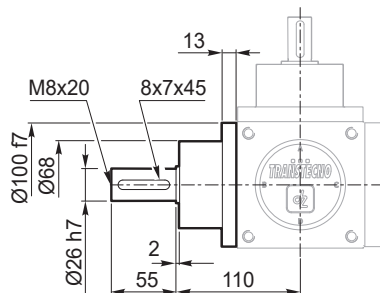
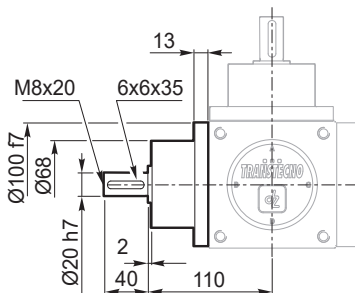
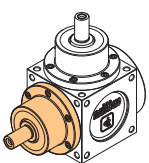

Forma costruttiva <i>Constructive forms</i>	25	26	27	50	51	52	54	56	58	63												
Versione standard <i>Standard version</i>																						
Versione rinforzata <i>Strengthened version</i>																						

Disponibile / Available

**Torretta C  
Bell housing C**

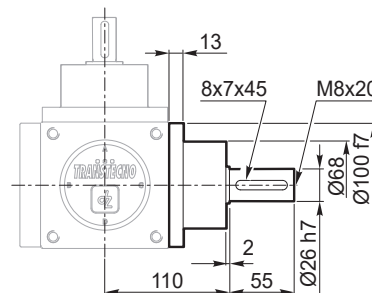
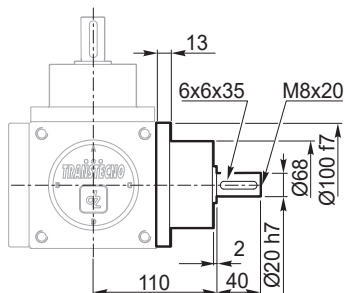
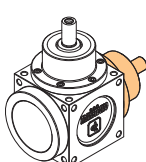

Forma costruttiva <i>Constructive forms</i>																						
Versione standard <i>Standard version</i>																						
Versione rinforzata <i>Strengthened version</i>																						

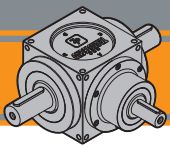

**Dimensioni**

**Dimensions**

**QB 134**

**Carter**

**Casing**

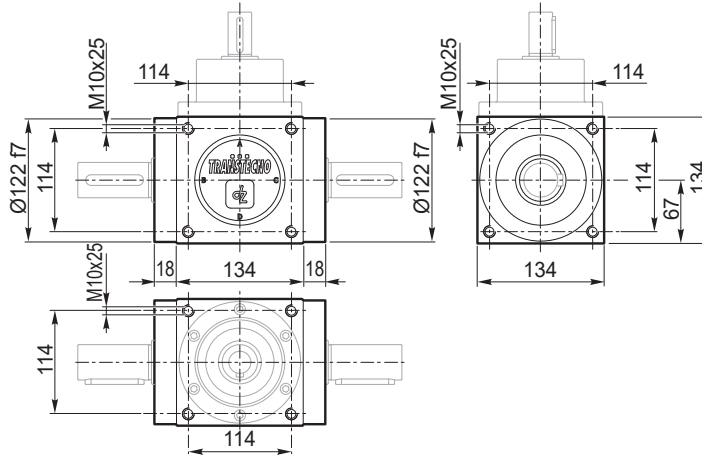
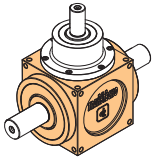

Forma costruttiva / Constructive forms: dalla 1 alla 68 - from 1 to 68

**Torretta A**

**Bell housing A**

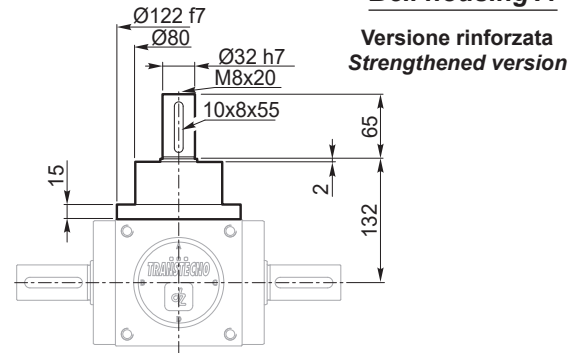
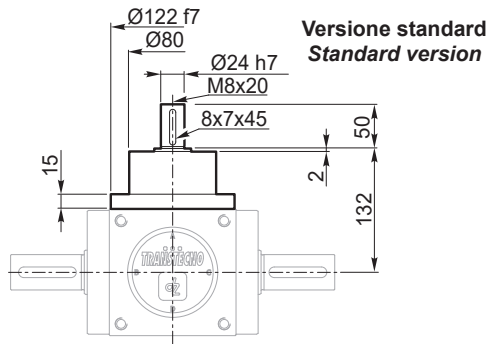
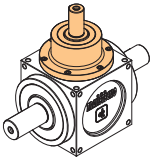

Forma costruttiva / Constructive forms	1	2	3	4	5	6	7	8	9	10	21	22	25	26	27	28	29	30	31	32	33	34	35	36	37	38	39	40	41	42	43	44	45	46	47	48	49	50	51	52	53	54	55					
Versione standard / Standard version																																																
Versione rinforzata / Strengthened version																																																

Disponibile / Available

**Versione PAM / Input flange version**

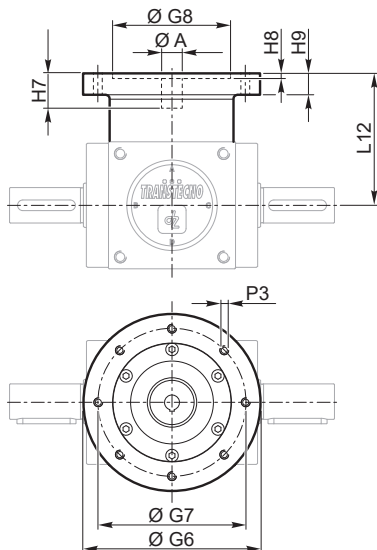
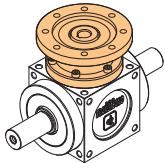

Flangia / Flange	ØA H7	G6	G7	G8	L12	H5	H6	H7	H8	H9	P3
71 B5	14	160	130	110	125	16.3	5	30	4	13	M8
80 B5	19	200	165	130	125	21.8	6	40	5	13	M10
80 B14	19	120	100	80	125	21.8	6	40	5	13	7
90 B5	24	200	165	130	125	27.3	8	50	5	13	M10
90 B14	24	140	115	95	125	27.3	8	50	5	13	9
100-112 B5	28	250	215	180	135	31.3	8	60	5	13	M12
100-112 B14	28	160	130	110	135	31.3	8	60	5	13	9

Forma costruttiva / Constructive forms	11	12	13	14	15	16	17	18	19	20	23	24	56	57	58	59	60	61	62	63	64	65	66	67	68
--	----	----	----	----	----	----	----	----	----	----	----	----	----	----	----	----	----	----	----	----	----	----	----	----	----

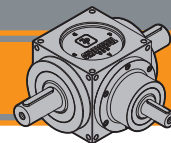

Dimensioni

Dimensions

QB 134

Torretta D

Bell housing D

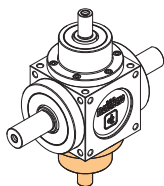

Versione standard  
Standard version

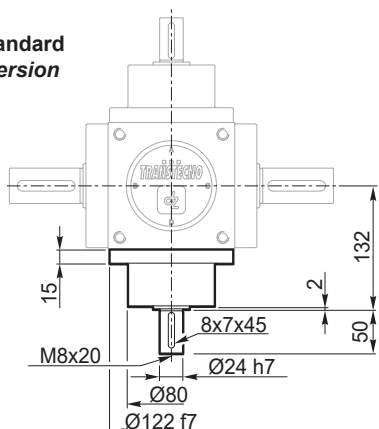

Versione rinforzata  
Strengthened version

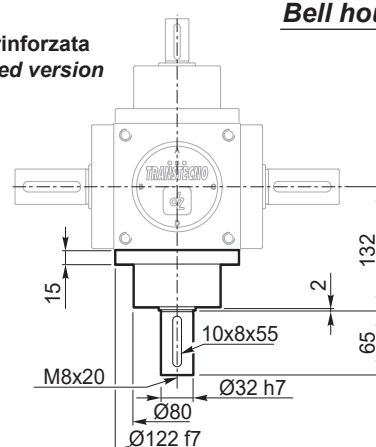

Il diametro della presa di forza della torretta D è sempre uguale al diametro della presa di forza della torretta A versione standard o rinforzata  
The diameter of the power take-off of bell housing D is always the same as the diameter of the power take-off of bell housing A standard or strengthened version

Forma costruttiva Constructive forms	6	7	8	9	10	16	17	18	19	20	22	24	31	32	33	36	37	38	39	43	46	47	48	50	54	55	58	59	65	66	
Versione standard Standard version																															
Versione rinforzata Strengthened version																															

Disponibile / Available

Torretta E

Bell housing E

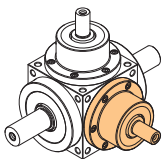

Versione standard  
Standard version

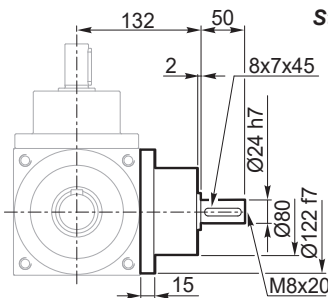

Versione rinforzata  
Strengthened version

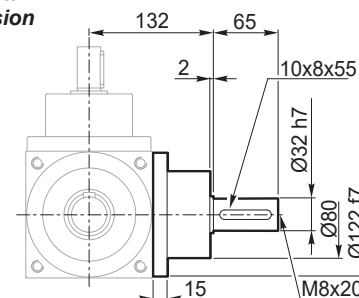

Il diametro della presa di forza della torretta E è sempre uguale al diametro della presa di forza della torretta A versione standard o rinforzata  
The diameter of the power take-off of bell housing E is always the same as the diameter of the power take-off of bell housing A standard or strengthened version

Forma costruttiva Constructive forms	34	35	36	37	38	39	40	41	43	44	45	46	47	48	51	52	53	54	55	61	62	63	64	65	66	
Versione standard Standard version																										
Versione rinforzata Strengthened version																										

Torretta F

Bell housing F

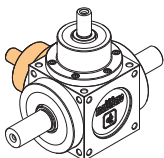

Versione standard  
Standard version

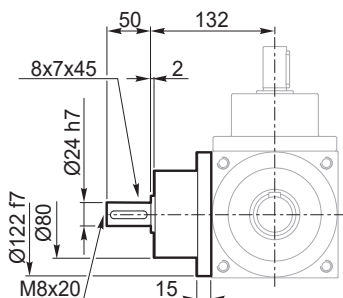

Versione rinforzata  
Strengthened version

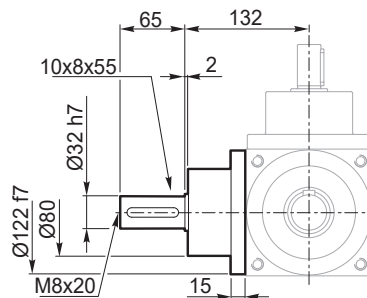

Il diametro della presa di forza della torretta F è sempre uguale al diametro della presa di forza della torretta A versione standard o rinforzata  
The diameter of the power take-off of bell housing F is always the same as the diameter of the power take-off of bell housing A standard or strengthened version

Forma costruttiva Constructive forms	38	39	42	44	45	46	47	48	52	53	54	55	60	61	63	65	66	67
Versione standard Standard version																		
Versione rinforzata Strengthened version																		

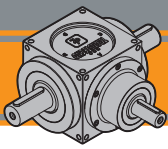

### Dimensioni

### Dimensions

## QB 134

### Asse B-C integrale

### B-C single output axis

#### Sporgente B-C Protruding B-C

**6.1**  
mm

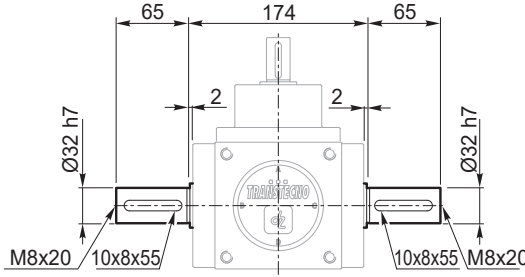
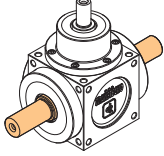

<b>Forma costruttiva Constructive forms</b>	1	6	11	16	40	43	48	62																	
---	---	---	----	----	----	----	----	----	--	--	--	--	--	--	--	--	--	--	--	--	--	--	--	--	--

#### Sporgente B Protruding B

**6.2**  
mm

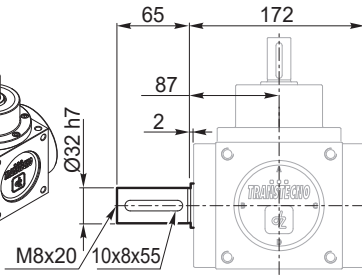
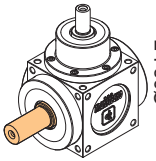

#### Sporgente C Protruding C

**6.3**  
mm

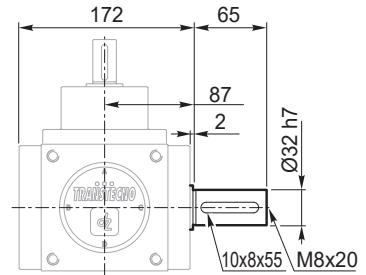
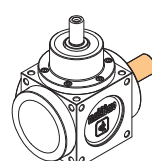

<b>Forma costruttiva Constructive forms</b>	2	7	12	17	41	44	46	68																
---	---	---	----	----	----	----	----	----	--	--	--	--	--	--	--	--	--	--	--	--	--	--	--	--

<b>Forma costruttiva Constructive forms</b>	3	8	13	18	42	45	47	67																
---	---	---	----	----	----	----	----	----	--	--	--	--	--	--	--	--	--	--	--	--	--	--	--	--

#### Albero cavo con linguetta Hollow shaft with key

**6.4**  
mm

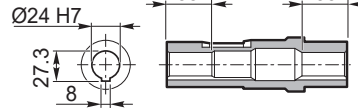
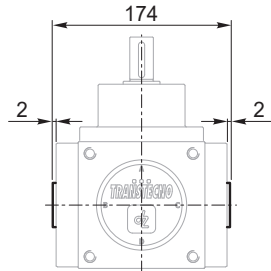
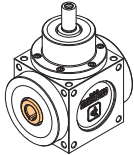

<b>Forma costruttiva Constructive forms</b>	4	9	14	19	34	36	38	60	61	64	65	66												
---	---	---	----	----	----	----	----	----	----	----	----	----	--	--	--	--	--	--	--	--	--	--	--	--

#### Albero cavo scanalato UNI 8953 Grooved hollow shaft UNI 8953

**6.5**  
mm

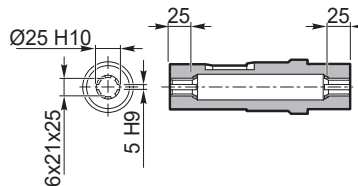
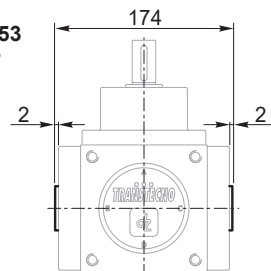
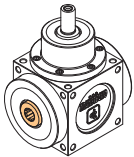

<b>Forma costruttiva Constructive forms</b>	5	10	15	20	35	37	39																	
---	---	----	----	----	----	----	----	--	--	--	--	--	--	--	--	--	--	--	--	--	--	--	--	--

#### Albero cavo con calettatore Hollow shaft with shrink disc

**6.6**  
mm

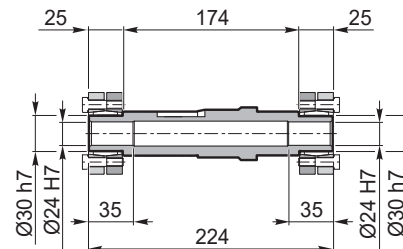
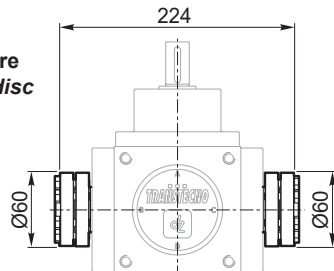
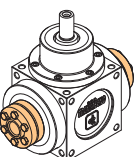

<b>Forma costruttiva Constructive forms</b>	21	22	23	24																				
---	----	----	----	----	--	--	--	--	--	--	--	--	--	--	--	--	--	--	--	--	--	--	--	--

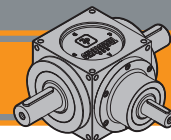

## Dimensioni

## Dimensions

### QB 134

#### Asse B-C con Torrette

#### Axis B-C with bell housing

#### Torrette B-C Bell Housings B-C

#### Versione standard Standard version

#### Versione rinforzata Strengthened version

7.1  
mm

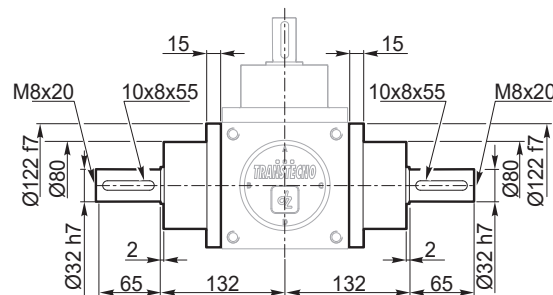
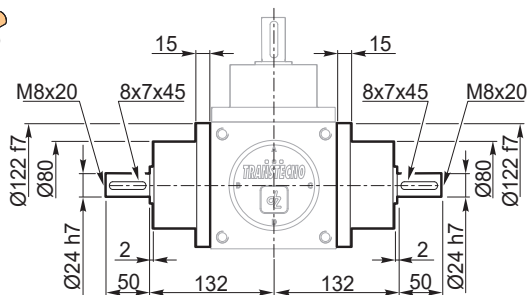
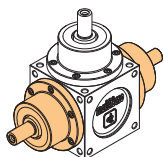

Forma costruttiva Constructive forms	28	29	30	31	32	33	49	53	55	57	59								
Versione standard Standard version																			
Versione rinforzata Strengthened version																			

■ Disponibile / Available

#### Torretta B Bell housing B

7.2  
mm

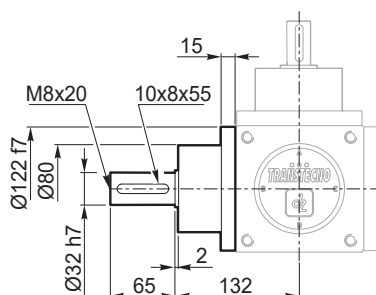
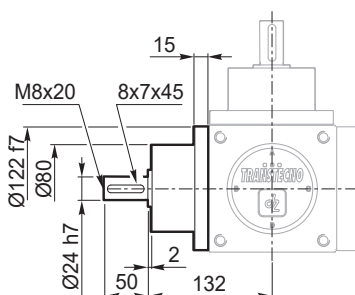
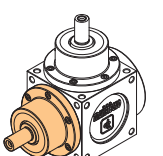

Forma costruttiva Constructive forms	25	26	27	50	51	52	54	56	58	63									
Versione standard Standard version																			
Versione rinforzata Strengthened version																			

■ Disponibile / Available

#### Torretta C Bell housing C

7.3  
mm

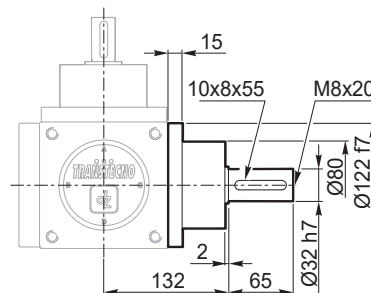
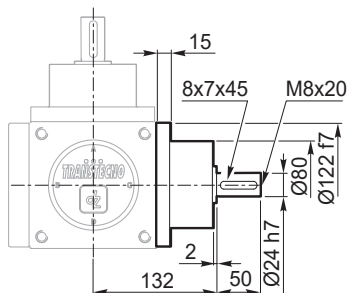
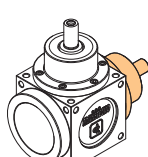

Forma costruttiva Constructive forms																			
Versione standard Standard version																			
Versione rinforzata Strengthened version																			

QB

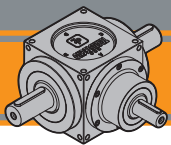

**Dimensioni**

**Dimensions**

**QB 166**

**Carter**

**Casing**

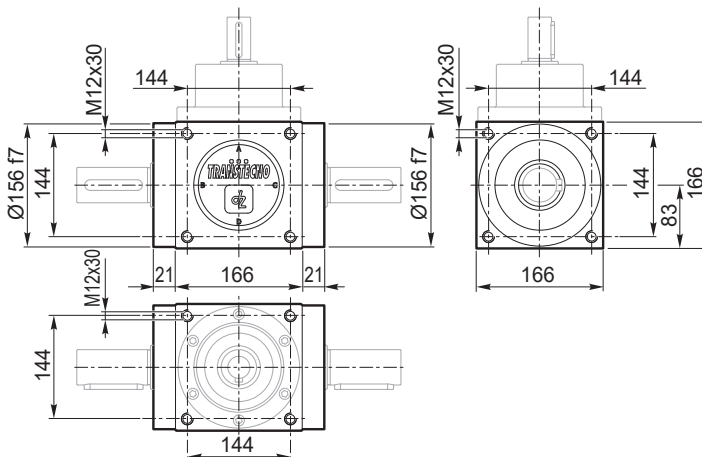
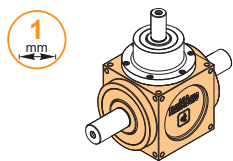

Forma costruttiva / Constructive forms: dalla 1 alla 68 - from 1 to 68

**Torretta A**

**Bell housing A**

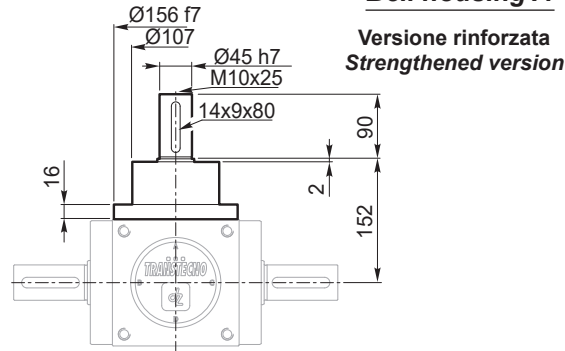
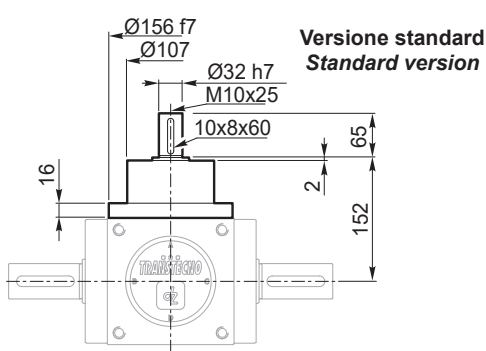
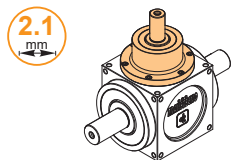

Forma costruttiva / Constructive forms	1	2	3	4	5	6	7	8	9	10	21	22	25	26	27	28	29	30	31	32	33	34	35	36	37	38	39	40	41	42	43	44	45	46	47	48	49	50	51	52	53	54	55										
Versione standard / Standard version																																																					
Versione rinforzata / Strengthened version																																																					

Disponibile / Available

**Versione PAM**  
**Input flange version**

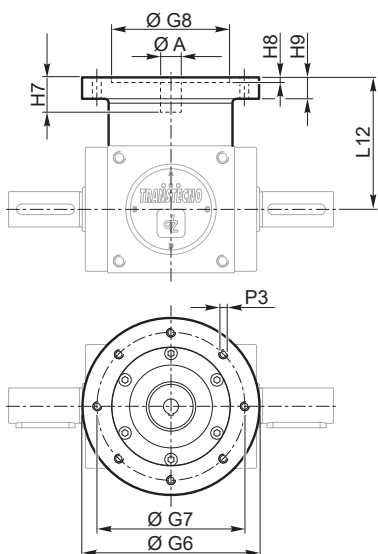
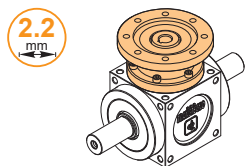

Flangia / Flange	ØA H7	G6	G7	G8	L12	H5	H6	H7	H8	H9	P3
<b>71 B5</b>	14	160	130	110	160	16.3	5	30	4	15	M8
<b>80 B5</b>	19	200	165	130	160	21.8	6	40	5	15	M10
<b>90 B5</b>	24	200	165	130	160	27.3	8	50	5	15	M10
<b>100-112 B5</b>	28	250	215	180	160	31.3	8	60	5	15	M12
<b>100-112 B14</b>	28	160	130	110	160	31.3	8	60	5	15	9

Forma costruttiva / Constructive forms	11	12	13	14	15	16	17	18	19	20	23	24	56	57	58	59	60	61	62	63	64	65	66	67	68
--	----	----	----	----	----	----	----	----	----	----	----	----	----	----	----	----	----	----	----	----	----	----	----	----	----



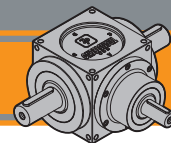

Dimensioni

Dimensions

QB 166

Torretta D

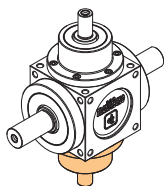

Versione standard  
Standard version

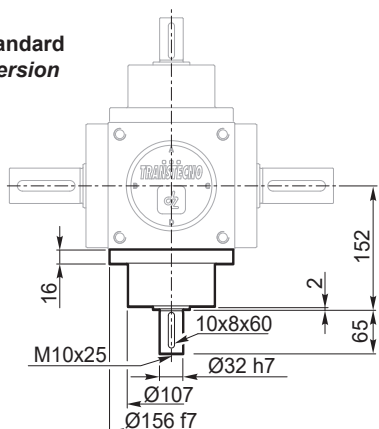

Versione rinforzata  
Strengthened version

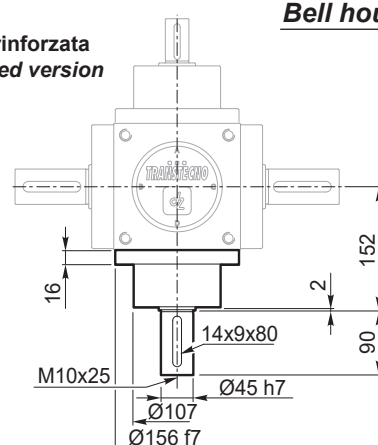

Bell housing D

Il diametro della presa di forza della torretta D è sempre uguale al diametro della presa di forza della torretta A versione standard o rinforzata  
The diameter of the power take-off of bell housing D is always the same as the diameter of the power take-off of bell housing A standard or strengthened version

Forma costruttiva Constructive forms	6	7	8	9	10	16	17	18	19	20	22	24	31	32	33	36	37	38	39	43	46	47	48	50	54	55	58	59	65	66	
Versione standard Standard version																															
Versione rinforzata Strengthened version																															

Disponibile / Available

Torretta E

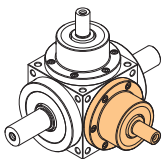

Versione standard  
Standard version

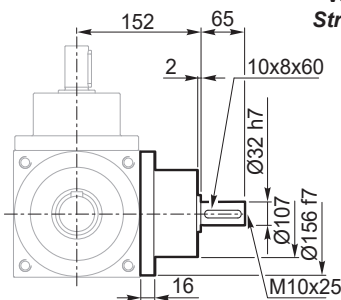

Versione rinforzata  
Strengthened version

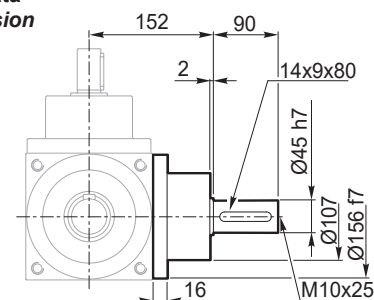

Bell housing E

Il diametro della presa di forza della torretta E è sempre uguale al diametro della presa di forza della torretta A versione standard o rinforzata  
The diameter of the power take-off of bell housing E is always the same as the diameter of the power take-off of bell housing A standard or strengthened version

Forma costruttiva Constructive forms	34	35	36	37	38	39	40	41	43	44	45	46	47	48	51	52	53	54	55	61	62	63	64	65	66	
Versione standard Standard version																										
Versione rinforzata Strengthened version																										

Torretta F

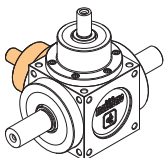

Versione standard  
Standard version

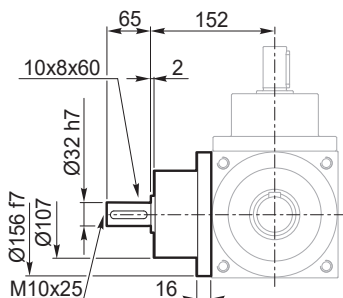

Versione rinforzata  
Strengthened version

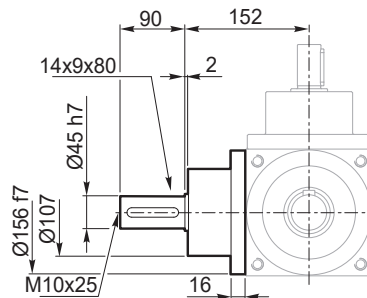

Bell housing F

Il diametro della presa di forza della torretta F è sempre uguale al diametro della presa di forza della torretta A versione standard o rinforzata  
The diameter of the power take-off of bell housing F is always the same as the diameter of the power take-off of bell housing A standard or strengthened version

Forma costruttiva Constructive forms	38	39	42	44	45	46	47	48	52	53	54	55	60	61	63	65	66	67
Versione standard Standard version																		
Versione rinforzata Strengthened version																		

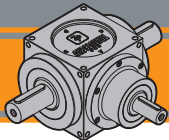

### QB 166

#### Asse B-C integrale

#### B-C single output axis

##### Sporgente B-C Protruding B-C

6.1  
mm

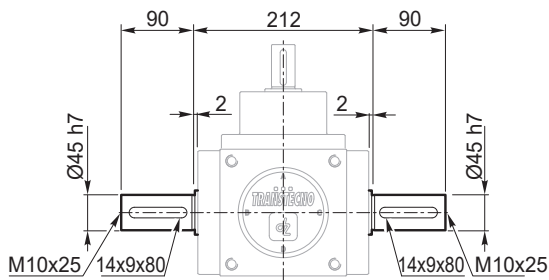
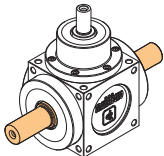

Forma costruttiva Constructive forms	1	6	11	16	40	43	48	62																		
---	---	---	----	----	----	----	----	----	--	--	--	--	--	--	--	--	--	--	--	--	--	--	--	--	--	--

##### Sporgente B Protruding B

6.2  
mm

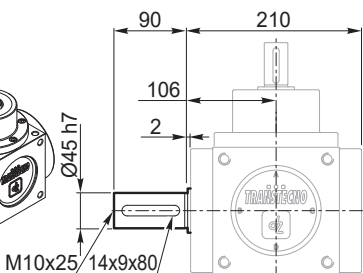
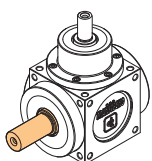

##### Sporgente C Protruding C

6.3  
mm

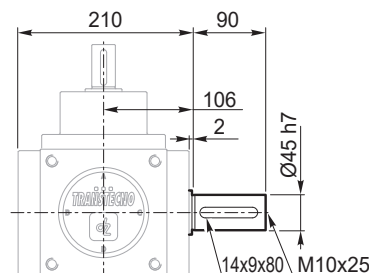
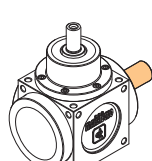

Forma costruttiva Constructive forms	2	7	12	17	41	44	46	68																	
---	---	---	----	----	----	----	----	----	--	--	--	--	--	--	--	--	--	--	--	--	--	--	--	--	--

Forma costruttiva Constructive forms	3	8	13	18	42	45	47	67																	
---	---	---	----	----	----	----	----	----	--	--	--	--	--	--	--	--	--	--	--	--	--	--	--	--	--

##### Albero cavo con linguetta Hollow shaft with key

6.4  
mm

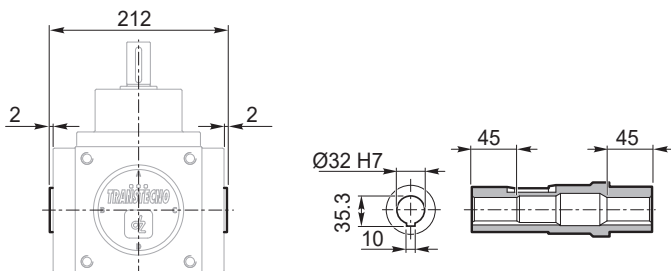
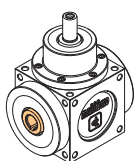

Forma costruttiva Constructive forms	4	9	14	19	34	36	38	60	61	64	65	66													
---	---	---	----	----	----	----	----	----	----	----	----	----	--	--	--	--	--	--	--	--	--	--	--	--	--

##### Albero cavo scanalato UNI 8953 Grooved hollow shaft UNI 8953

6.5  
mm

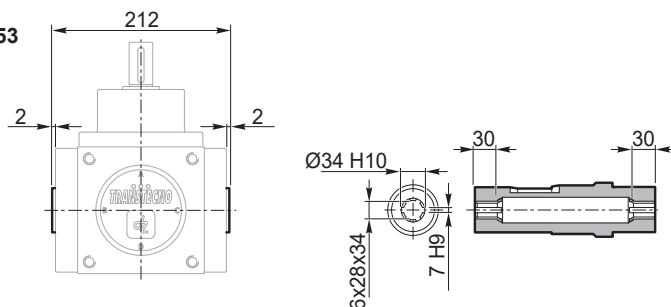
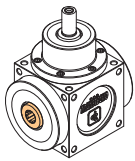

Forma costruttiva Constructive forms	5	10	15	20	35	37	39																		
---	---	----	----	----	----	----	----	--	--	--	--	--	--	--	--	--	--	--	--	--	--	--	--	--	--

##### Albero cavo con calettatore Hollow shaft with shrink disc

6.6  
mm

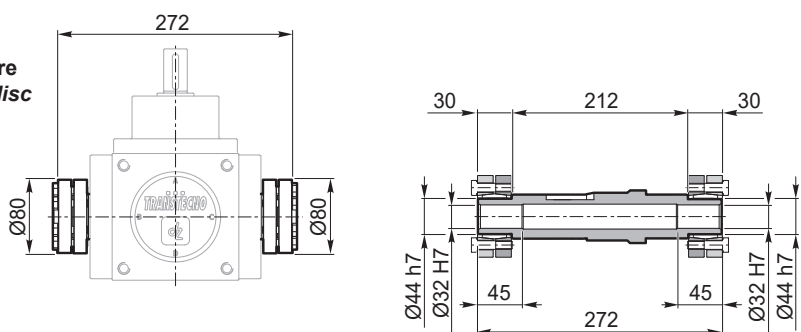
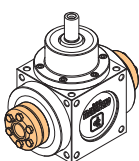

Forma costruttiva Constructive forms	21	22	23	24																					
---	----	----	----	----	--	--	--	--	--	--	--	--	--	--	--	--	--	--	--	--	--	--	--	--	--

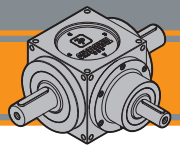

Dimensioni

Dimensions

**QB 166**

**Asse B-C con Torrette**

**Axis B-C with bell housing**

**Torrette B-C**  
**Bell Housings B-C**

7.1  
mm

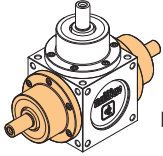

**Versione standard**  
**Standard version**

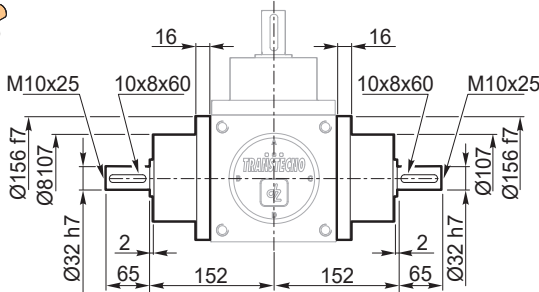

**Versione rinforzata**  
**Strengthened version**

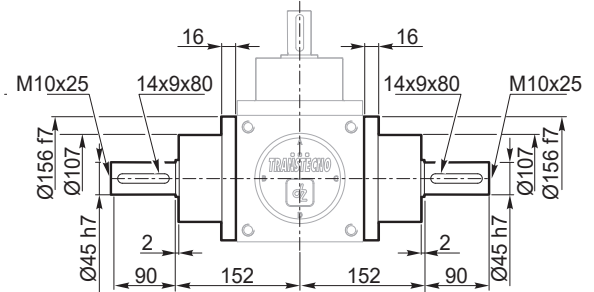

Forma costruttiva Constructive forms	28	29	30	31	32	33	49	53	55	57	59								
Versione standard Standard version																			
Versione rinforzata Strengthened version																			

Disponibile / Available

**Torretta B**  
**Bell housing B**

7.2  
mm

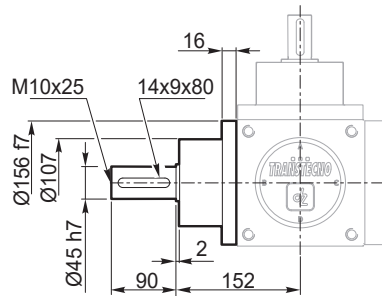
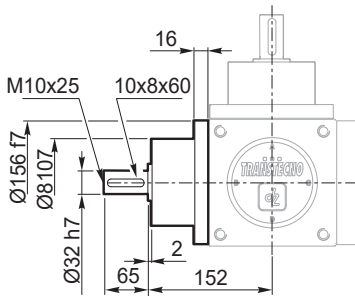
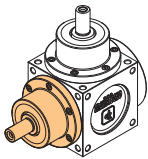

Forma costruttiva Constructive forms	25	26	27	50	51	52	54	56	58	63									
Versione standard Standard version																			
Versione rinforzata Strengthened version																			

Disponibile / Available

**Torretta C**  
**Bell housing C**

7.3  
mm

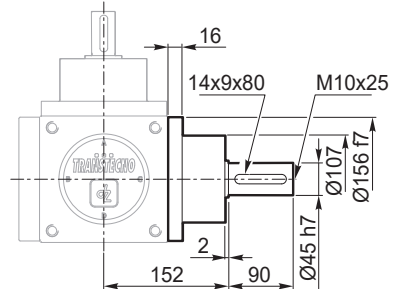
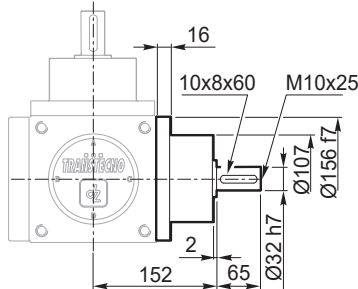
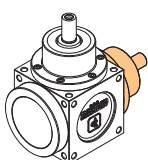

Forma costruttiva Constructive forms																			
Versione standard Standard version																			
Versione rinforzata Strengthened version																			

QB

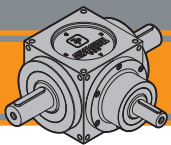

**Dimensioni**

**Dimensions**

**QB 200**

**Carter**

**Casing**

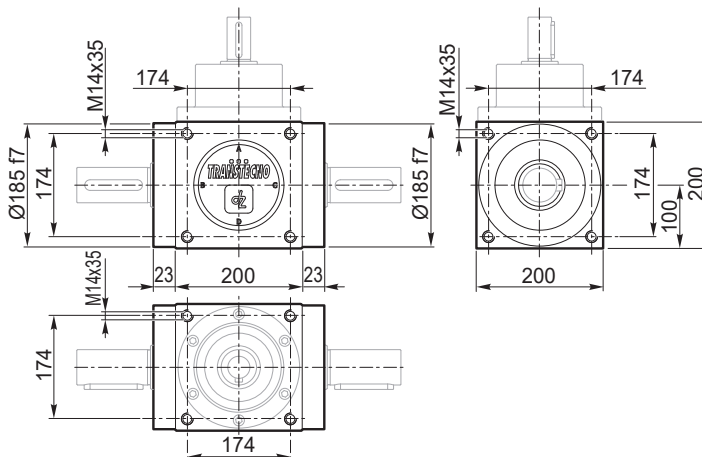
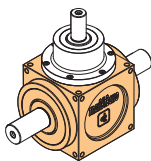

**Forma costruttiva**  
**Constructive forms**

dalla 1 alla 68 - from 1 to 68

**Torretta A**

**Bell housing A**

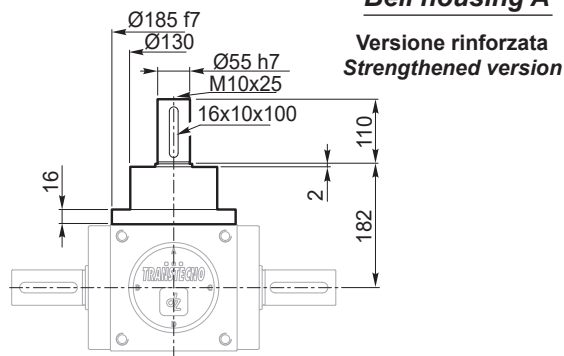
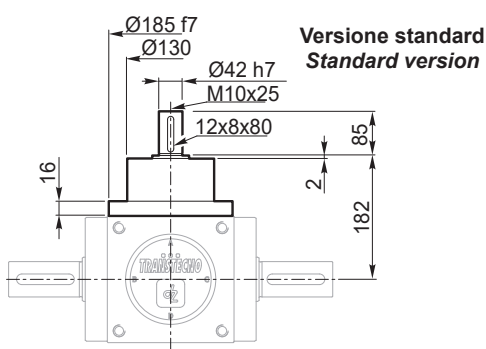
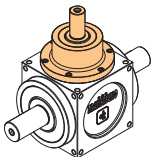

Forma costruttiva Constructive forms	1	2	3	4	5	6	7	8	9	10	21	22	25	26	27	28	29	30	31	32	33	34	35	36	37	38	39	40	41	42	43	44	45	46	47	48	49	50	51	52	53	54	55								
Versione standard Standard version																																																			
Versione rinforzata Strengthened version																																																			

Disponibile / Available

**Versione PAM**  
**Input flange version**

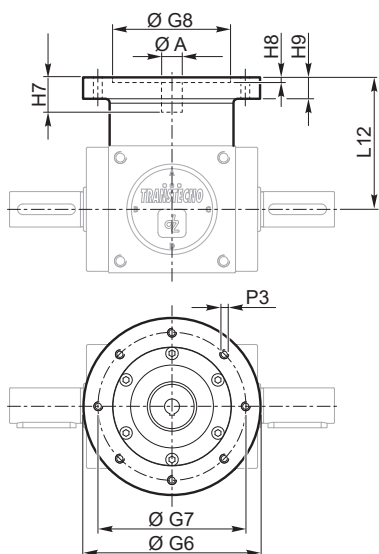
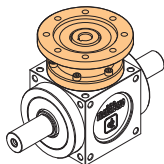

Flangia Flange	ØA H7	G6	G7	G8	L12	H5	H6	H7	H8	H9	P3
<b>90 B5</b>	24	200	165	130	220	27.3	8	50	5	23	M10
<b>100-112 B5</b>	28	250	215	180	220	31.3	8	60	5	23	M12
<b>132 B5</b>	38	300	265	230	220	41.3	10	80	6	23	M12
<b>132 B14</b>	38	200	165	130	220	41.3	10	80	6	23	11

**Forma costruttiva**  
**Constructive forms**

11	12	13	14	15	16	17	18	19	20	23	24	56	57	58	59	60	61	62	63	64	65	66	67	68
----	----	----	----	----	----	----	----	----	----	----	----	----	----	----	----	----	----	----	----	----	----	----	----	----

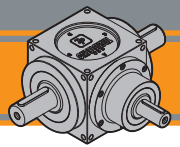

Dimensioni

Dimensions

**QB 200**

**Torretta D**

**Bell housing D**

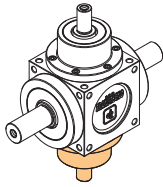

Versione standard  
Standard version

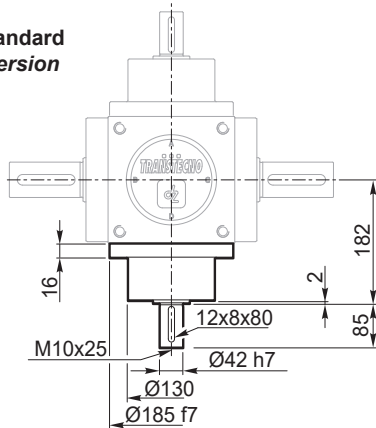

Versione rinforzata  
Strengthened version

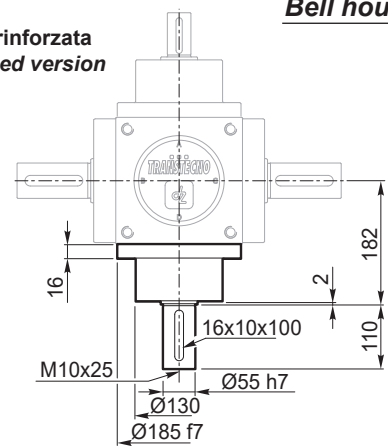

Il diametro della presa di forza della torretta D è sempre uguale al diametro della presa di forza della torretta A versione standard o rinforzata  
The diameter of the power take-off of bell housing D is always the same as the diameter of the power take-off of bell housing A standard or strengthened version

Forma costruttiva Constructive forms	6	7	8	9	10	16	17	18	19	20	22	24	31	32	33	36	37	38	39	43	46	47	48	50	54	55	58	59	65	66	
Versione standard Standard version																															
Versione rinforzata Strengthened version																															

Disponibile / Available

**Torretta E**

**Bell housing E**

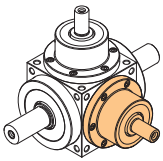

Versione standard  
Standard version

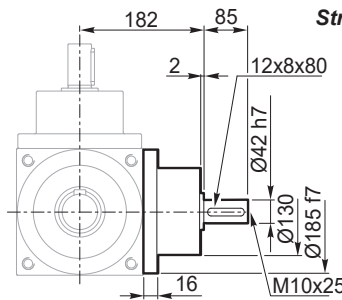

Versione rinforzata  
Strengthened version

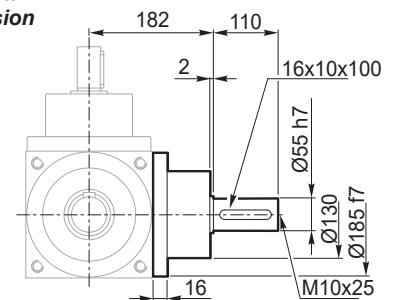

Il diametro della presa di forza della torretta E è sempre uguale al diametro della presa di forza della torretta A versione standard o rinforzata  
The diameter of the power take-off of bell housing E is always the same as the diameter of the power take-off of bell housing A standard or strengthened version

Forma costruttiva Constructive forms	34	35	36	37	38	39	40	41	43	44	45	46	47	48	51	52	53	54	55	61	62	63	64	65	66	
Versione standard Standard version																										
Versione rinforzata Strengthened version																										

**Torretta F**

**Bell housing F**

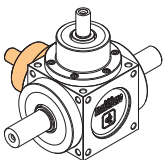

Versione standard  
Standard version

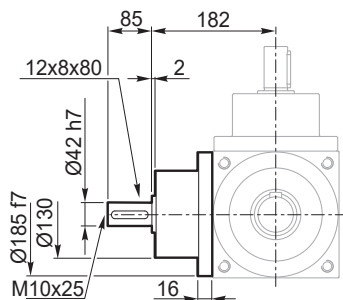

Versione rinforzata  
Strengthened version

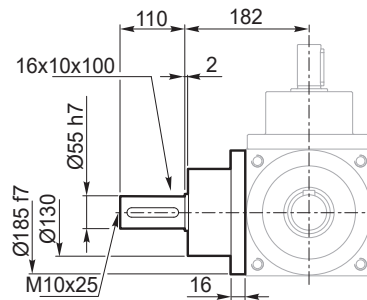

Il diametro della presa di forza della torretta F è sempre uguale al diametro della presa di forza della torretta A versione standard o rinforzata  
The diameter of the power take-off of bell housing F is always the same as the diameter of the power take-off of bell housing A standard or strengthened version

Forma costruttiva Constructive forms	38	39	42	44	45	46	47	48	52	53	54	55	60	61	63	65	66	67
Versione standard Standard version																		
Versione rinforzata Strengthened version																		

QB

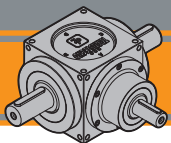

# QB Rinvii angolari Right-angle bevel gearboxes

## Dimensioni

## Dimensions

### QB 200

#### Asse B-C integrale

#### B-C single output axis

##### Sporgente B-C Protruding B-C

6.1  
mm

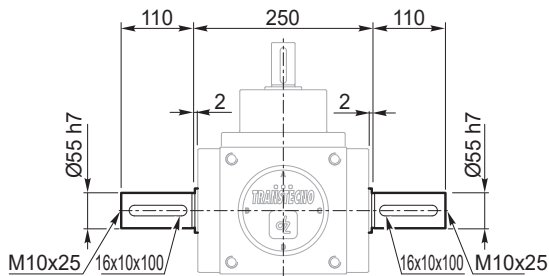
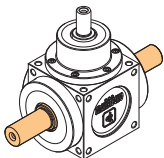

<b>Forma costruttiva</b> <i>Constructive forms</i>	1	6	11	16	40	43	48	62												
---	---	---	----	----	----	----	----	----	--	--	--	--	--	--	--	--	--	--	--	--

##### Sporgente B Protruding B

6.2  
mm

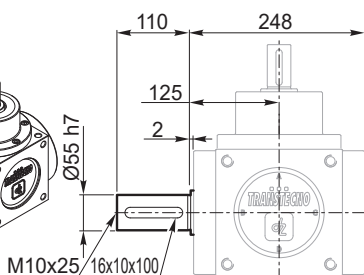
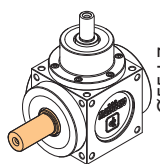

##### Sporgente C Protruding C

6.3  
mm

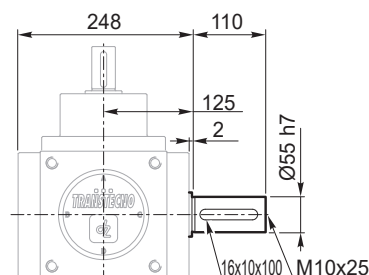
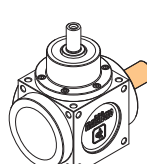

<b>Forma costruttiva</b> <i>Constructive forms</i>	2	7	12	17	41	44	46	68												
---	---	---	----	----	----	----	----	----	--	--	--	--	--	--	--	--	--	--	--	--

<b>Forma costruttiva</b> <i>Constructive forms</i>	3	8	13	18	42	45	47	67												
---	---	---	----	----	----	----	----	----	--	--	--	--	--	--	--	--	--	--	--	--

##### Albero cavo con linguetta Hollow shaft with key

6.4  
mm

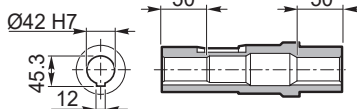
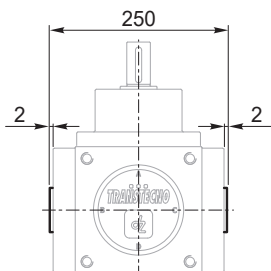
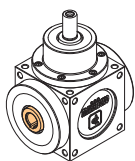

<b>Forma costruttiva</b> <i>Constructive forms</i>	4	9	14	19	34	36	38	60	61	64	65	66								
---	---	---	----	----	----	----	----	----	----	----	----	----	--	--	--	--	--	--	--	--

##### Albero cavo scanalato UNI 8953 Grooved hollow shaft UNI 8953

6.5  
mm

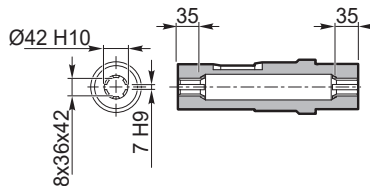
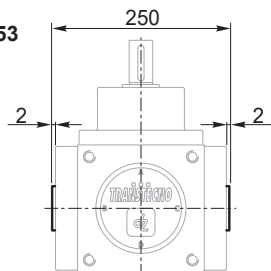
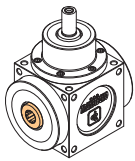

<b>Forma costruttiva</b> <i>Constructive forms</i>	5	10	15	20	35	37	39													
---	---	----	----	----	----	----	----	--	--	--	--	--	--	--	--	--	--	--	--	--

##### Albero cavo con calettatore Hollow shaft with shrink disc

6.6  
mm

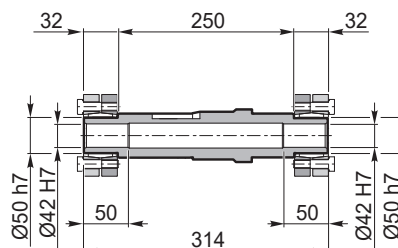
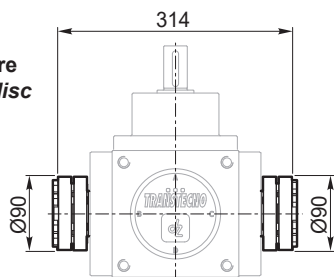
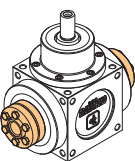

<b>Forma costruttiva</b> <i>Constructive forms</i>	21	22	23	24																
---	----	----	----	----	--	--	--	--	--	--	--	--	--	--	--	--	--	--	--	--

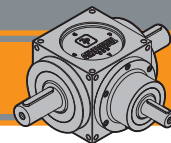

Dimensioni

Dimensions

QB 200

Asse B-C con Torrette

Axis B-C with bell housing

Torrette B-C  
Bell Housings B-C

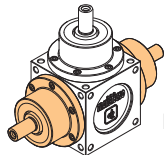

Versione standard  
Standard version

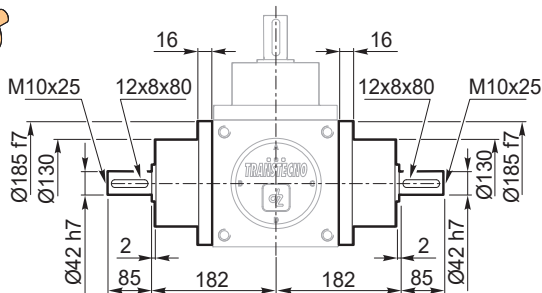

Versione rinforzata  
Strengthened version

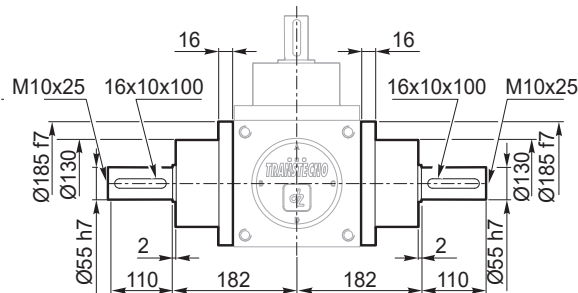

Forma costruttiva Constructive forms	28	29	30	31	32	33	49	53	55	57	59												
Versione standard Standard version																							
Versione rinforzata Strengthened version																							

Disponibile / Available

Torretta B  
Bell housing B

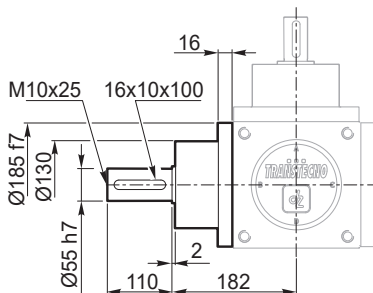
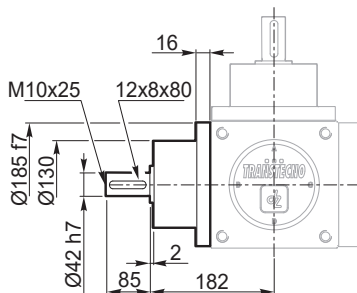
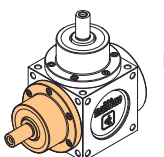

Forma costruttiva Constructive forms	25	26	27	50	51	52	54	56	58	63												
Versione standard Standard version																						
Versione rinforzata Strengthened version																						

Disponibile / Available

Torretta C  
Bell housing C

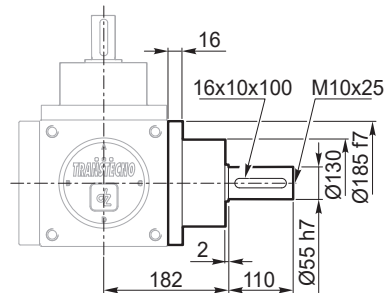
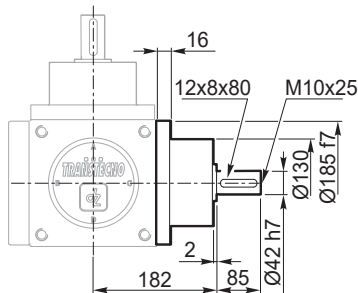
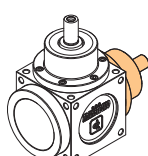

Forma costruttiva Constructive forms																						
Versione standard Standard version																						
Versione rinforzata Strengthened version																						

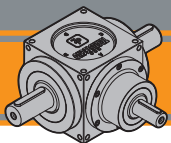

# QB Rinvii angolari Right-angle bevel gearboxes

Dimensioni

Dimensions

## QB 250

Carter

Casing

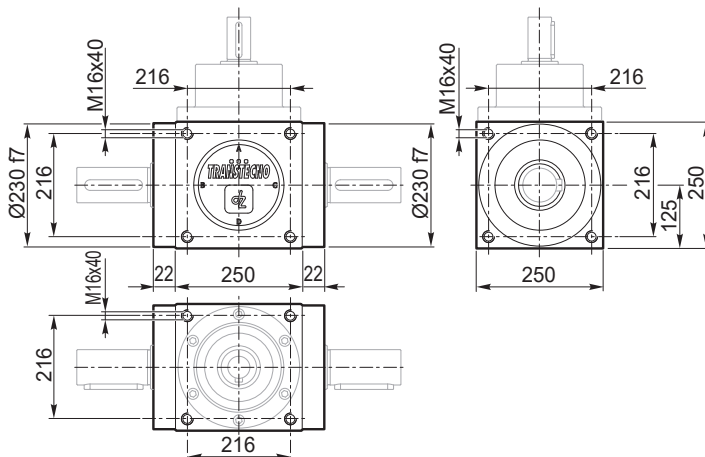
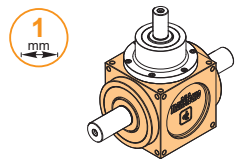

Forma costruttiva  
Constructive forms

dalla 1 alla 68 - from 1 to 68

Torretta A

Bell housing A

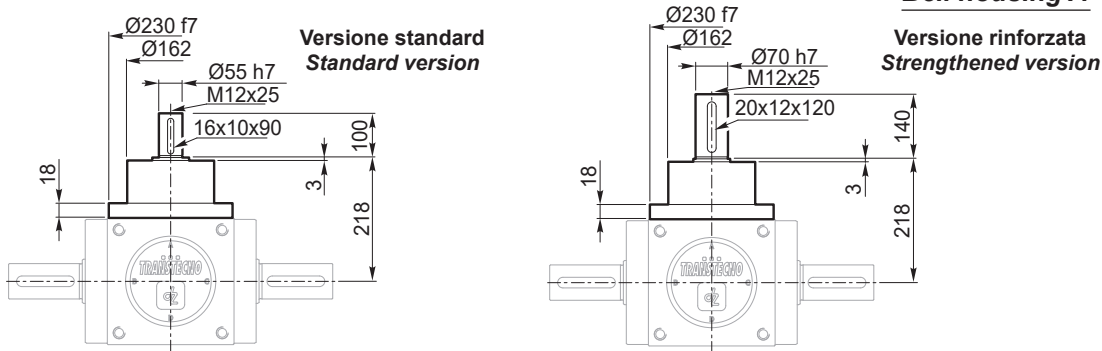
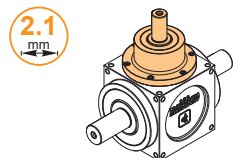

Forma costruttiva Constructive forms	1	2	3	4	5	6	7	8	9	10	21	22	25	26	27	28	29	30	31	32	33	34	35	36	37	38	39	40	41	42	43	44	45	46	47	48	49	50	51	52	53	54	55								
Versione standard Standard version																																																			
Versione rinforzata Strengthened version																																																			

Disponibile / Available

Versione PAM  
Input flange version

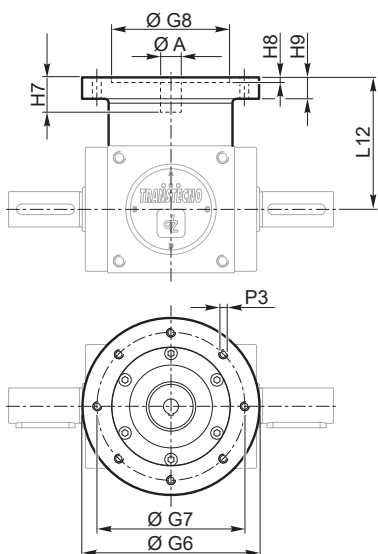
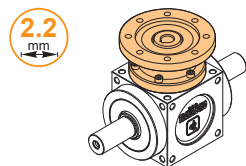

Flangia Flange	$\varnothing A$ $H7$	G6	G7	G8	L12	H5	H6	H7	H8	H9	P3
132 B5	38	300	265	230	250	41.3	10	80	6	25	M12
132 B14	38	200	165	130	250	41.3	10	80	6	25	11
160 B5	42	350	300	250	250	45.8	12	110	6	25	M16

Forma costruttiva Constructive forms	11	12	13	14	15	16	17	18	19	20	23	24	56	57	58	59	60	61	62	63	64	65	66	67	68	



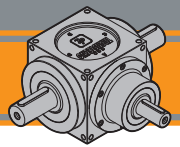

Dimensioni

Dimensions

**QB 250**

**Torretta D**

**Bell housing D**

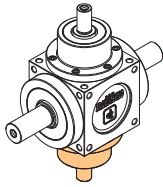

**Versione standard**  
Standard version

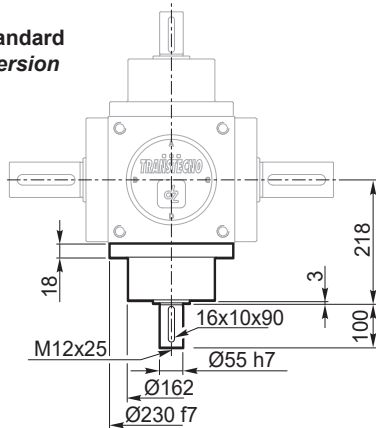

**Versione rinforzata**  
Strengthened version

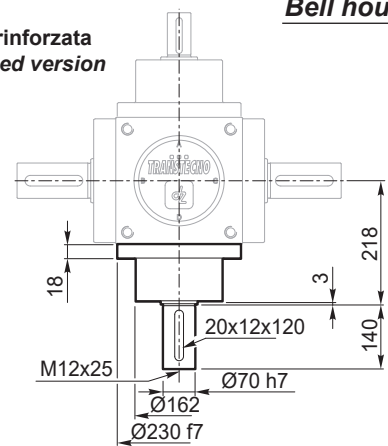

Il diametro della presa di forza della torretta D è sempre uguale al diametro della presa di forza della torretta A versione standard o rinforzata  
The diameter of the power take-off of bell housing D is always the same as the diameter of the power take-off of bell housing A standard or strengthened version

<b>Forma costruttiva</b> Constructive forms	6	7	8	9	10	16	17	18	19	20	22	24	31	32	33	36	37	38	39	43	46	47	48	50	54	55	58	59	65	66	
<b>Versione standard</b> Standard version																															
<b>Versione rinforzata</b> Strengthened version																															

Disponibile / Available

**Torretta E**

**Bell housing E**

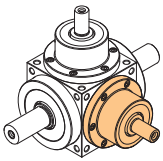

**Versione standard**  
Standard version

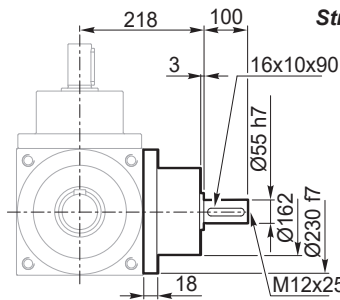

**Versione rinforzata**  
Strengthened version

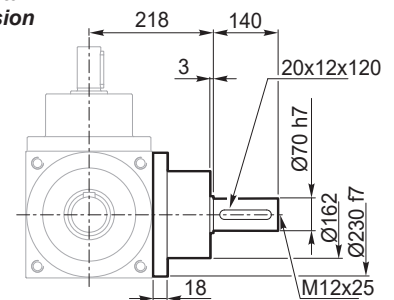

Il diametro della presa di forza della torretta E è sempre uguale al diametro della presa di forza della torretta A versione standard o rinforzata  
The diameter of the power take-off of bell housing E is always the same as the diameter of the power take-off of bell housing A standard or strengthened version

<b>Forma costruttiva</b> Constructive forms	34	35	36	37	38	39	40	41	43	44	45	46	47	48	51	52	53	54	55	61	62	63	64	65	66	
<b>Versione standard</b> Standard version																										
<b>Versione rinforzata</b> Strengthened version																										

**Torretta F**

**Bell housing F**

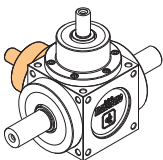

**Versione standard**  
Standard version

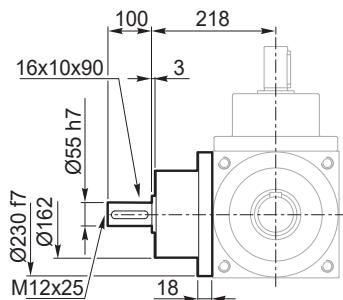

**Versione rinforzata**  
Strengthened version

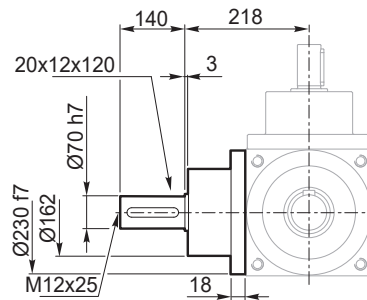

Il diametro della presa di forza della torretta F è sempre uguale al diametro della presa di forza della torretta A versione standard o rinforzata  
The diameter of the power take-off of bell housing F is always the same as the diameter of the power take-off of bell housing A standard or strengthened version

<b>Forma costruttiva</b> Constructive forms	38	39	42	44	45	46	47	48	52	53	54	55	60	61	63	65	66	67
<b>Versione standard</b> Standard version																		
<b>Versione rinforzata</b> Strengthened version																		

QB

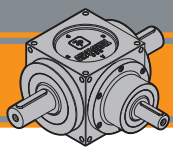

Dimensioni

Dimensions

QB 250

Asse B-C integrale

B-C single output axis

Sporgente B-C  
Protruding B-C

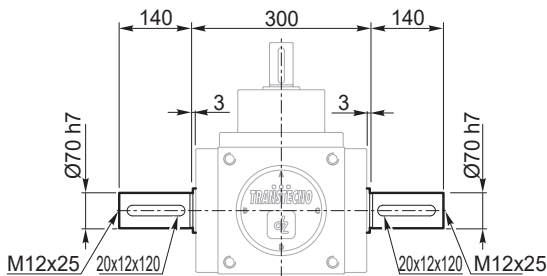
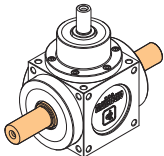

Forma costruttiva Constructive forms	1	6	11	16	40	43	48	62																										
---	---	---	----	----	----	----	----	----	--	--	--	--	--	--	--	--	--	--	--	--	--	--	--	--	--	--	--	--	--	--	--	--	--	--

Sporgente B  
Protruding B

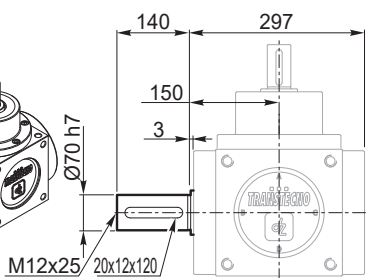
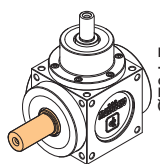

Sporgente C  
Protruding C

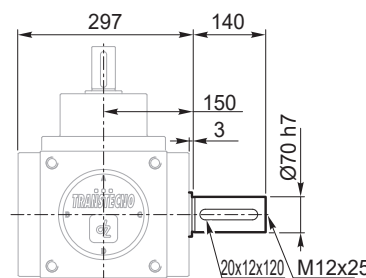
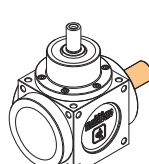

Forma costruttiva Constructive forms	2	7	12	17	41	44	46	68																										
---	---	---	----	----	----	----	----	----	--	--	--	--	--	--	--	--	--	--	--	--	--	--	--	--	--	--	--	--	--	--	--	--	--	--

Forma costruttiva Constructive forms	3	8	13	18	42	45	47	67																										
---	---	---	----	----	----	----	----	----	--	--	--	--	--	--	--	--	--	--	--	--	--	--	--	--	--	--	--	--	--	--	--	--	--	--

Albero cavo con linguetta  
Hollow shaft with key

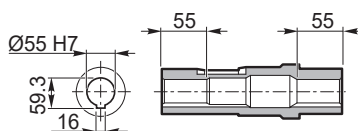
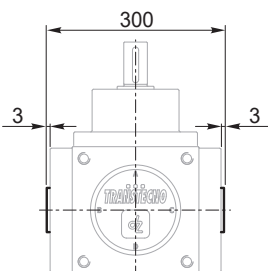
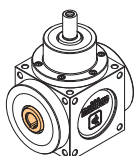

Forma costruttiva Constructive forms	4	9	14	19	34	36	38	60	61	64	65	66																						
---	---	---	----	----	----	----	----	----	----	----	----	----	--	--	--	--	--	--	--	--	--	--	--	--	--	--	--	--	--	--	--	--	--	--

Albero cavo scanalato UNI 8953  
Grooved hollow shaft UNI 8953

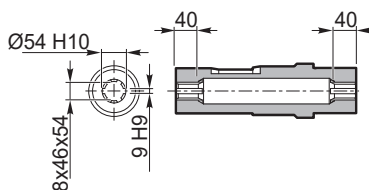
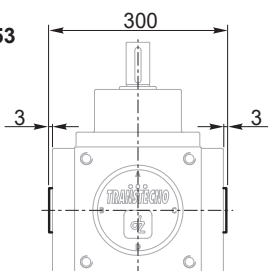
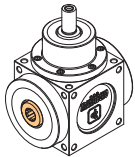

Forma costruttiva Constructive forms	5	10	15	20	35	37	39																											
---	---	----	----	----	----	----	----	--	--	--	--	--	--	--	--	--	--	--	--	--	--	--	--	--	--	--	--	--	--	--	--	--	--	--

Albero cavo con calettatore  
Hollow shaft with shrink disc

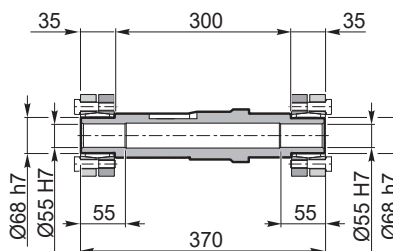
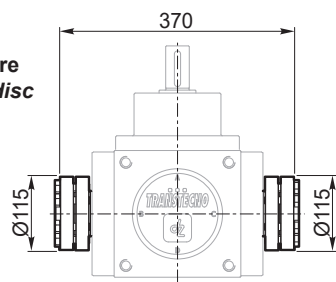
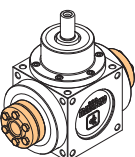

Forma costruttiva Constructive forms	21	22	23	24																															
---	----	----	----	----	--	--	--	--	--	--	--	--	--	--	--	--	--	--	--	--	--	--	--	--	--	--	--	--	--	--	--	--	--	--	--

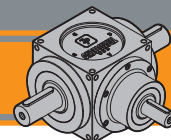

Dimensioni

Dimensions

**QB 250**

Asse B-C con Torrette

Axis B-C with bell housing

Torrette B-C  
Bell Housings B-C

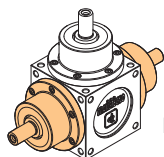

Versione standard  
Standard version

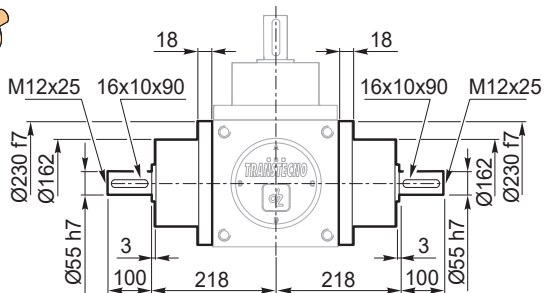

Versione rinforzata  
Strengthened version

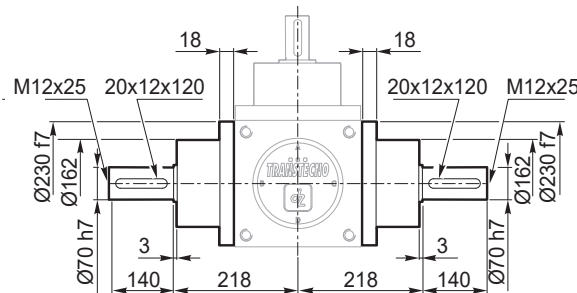

Forma costruttiva Constructive forms	28	29	30	31	32	33	49	53	55	57	59														
Versione standard Standard version																									
Versione rinforzata Strengthened version																									

Disponibile / Available

Torretta B  
Bell housing B

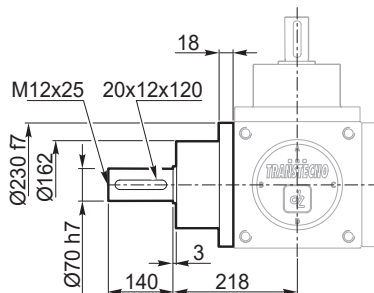
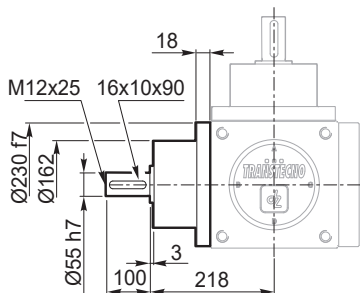
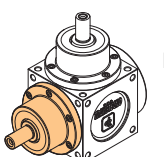

Forma costruttiva Constructive forms	25	26	27	50	51	52	54	56	58	63															
Versione standard Standard version																									
Versione rinforzata Strengthened version																									

Disponibile / Available

Torretta C  
Bell housing C

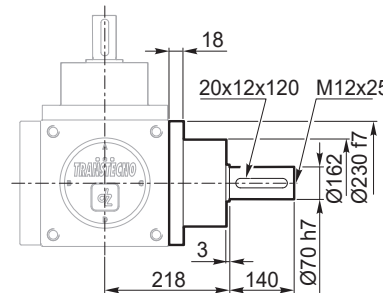
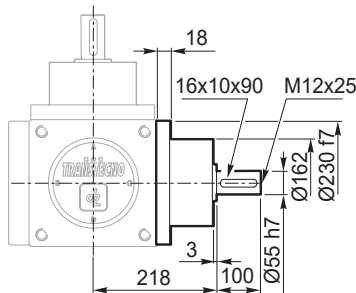
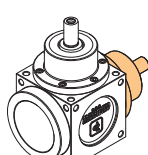

Forma costruttiva Constructive forms																									
Versione standard Standard version																									
Versione rinforzata Strengthened version																									

QB

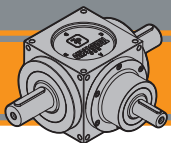

# QB Rinvii angolari Right-angle bevel gearboxes

## Dimensioni

## Dimensions

# QB 350

### Carter

### Casing

1  
mm

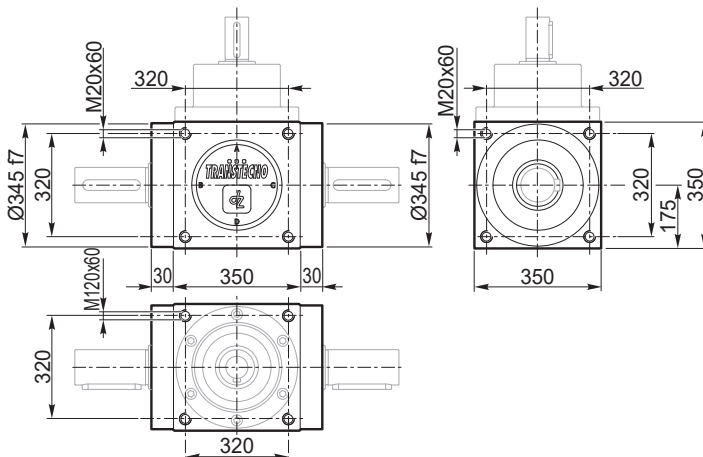
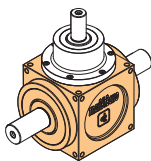

Forma costruttiva  
Constructive forms

dalla 1 alla 68 - from 1 to 68

### Torretta A

### Bell housing A

2.1  
mm

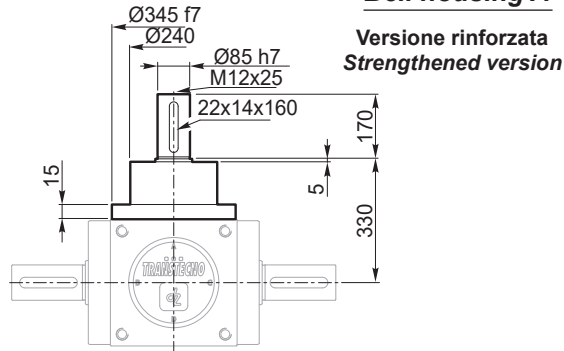
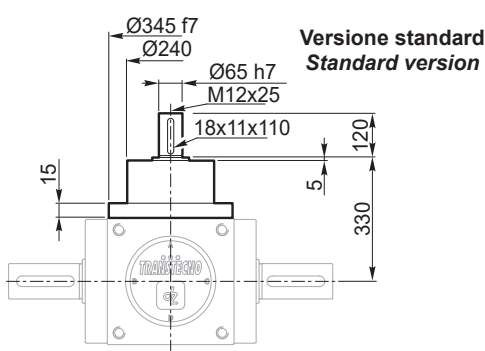
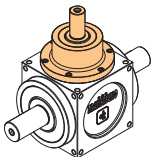

Forma costruttiva Constructive forms	1	2	3	4	5	6	7	8	9	10	21	22	25	26	27	28	29	30	31	32	33	34	35	36	37	38	39	40	41	42	43	44	45	46	47	48	49	50	51	52	53	54	55						
Versione standard Standard version																																																	
Versione rinforzata Strengthened version																																																	

Disponibile / Available

### Versione PAM Input flange version

2.2  
mm

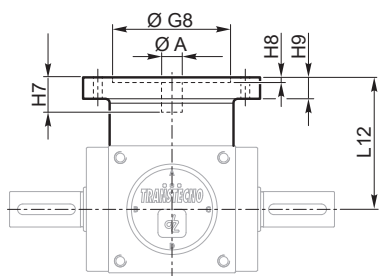
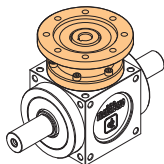

Flangia Flange	ØA	G6	G7	G8	L12	H5	H6	H7	H8	H9	P3
	H7										

Non disponibile / Not available

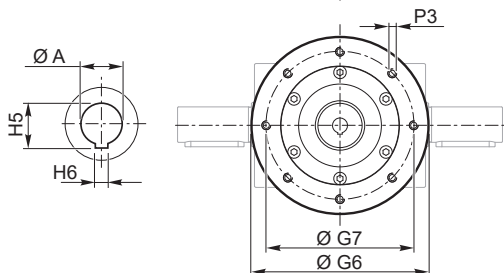

Forma costruttiva  
Constructive forms

--	--	--	--	--	--	--	--	--	--	--	--	--	--	--	--	--	--	--	--	--	--	--	--	--	--	--	--	--	--	--	--	--	--	--	--	--	--	--	--	--	--	--	--	--	--	--	--

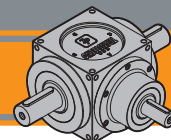

Dimensioni

Dimensions

**QB 350**

**Torretta D**

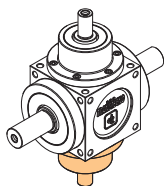

**Versione standard**  
Standard version

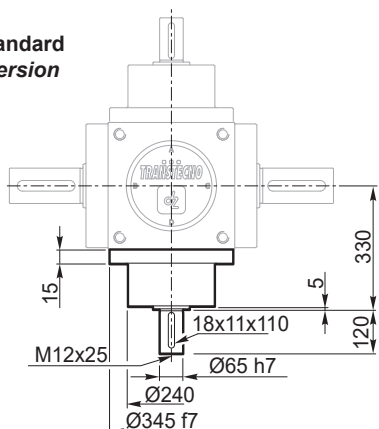

**Versione rinforzata**  
Strengthened version

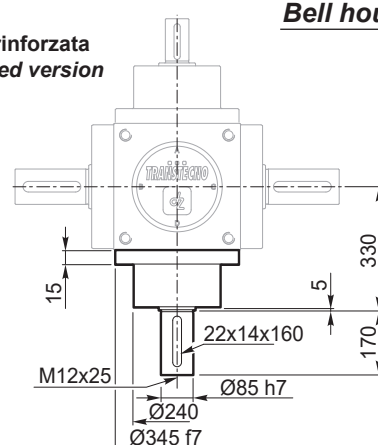

**Bell housing D**

Il diametro della presa di forza della torretta D è sempre uguale al diametro della presa di forza della torretta A versione standard o rinforzata  
The diameter of the power take-off of bell housing D is always the same as the diameter of the power take-off of bell housing A standard or strengthened version

<b>Forma costruttiva</b> Constructive forms	6	7	8	9	10	16	17	18	19	20	22	24	31	32	33	36	37	38	39	43	46	47	48	50	54	55	58	59	65	66	
<b>Versione standard</b> Standard version																															
<b>Versione rinforzata</b> Strengthened version																															

Disponibile / Available

**Torretta E**

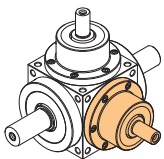

**Versione standard**  
Standard version

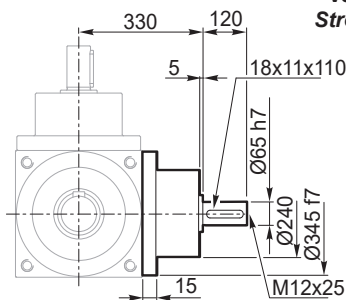

**Versione rinforzata**  
Strengthened version

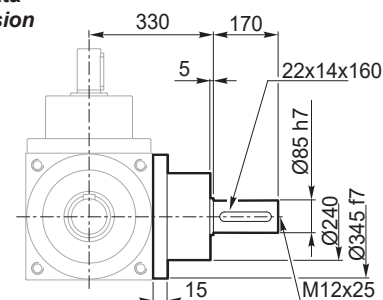

**Bell housing E**

Il diametro della presa di forza della torretta E è sempre uguale al diametro della presa di forza della torretta A versione standard o rinforzata  
The diameter of the power take-off of bell housing E is always the same as the diameter of the power take-off of bell housing A standard or strengthened version

<b>Forma costruttiva</b> Constructive forms	34	35	36	37	38	39	40	41	43	44	45	46	47	48	51	52	53	54	55	61	62	63	64	65	66	
<b>Versione standard</b> Standard version																										
<b>Versione rinforzata</b> Strengthened version																										

**Torretta F**

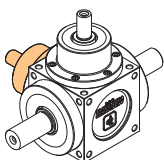

**Versione standard**  
Standard version

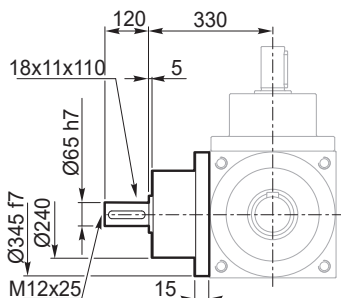

**Versione rinforzata**  
Strengthened version

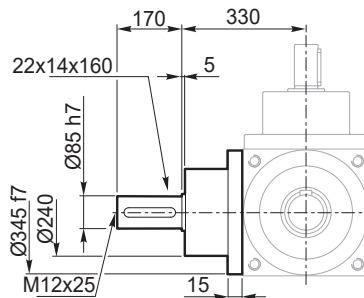

**Bell housing F**

Il diametro della presa di forza della torretta F è sempre uguale al diametro della presa di forza della torretta A versione standard o rinforzata  
The diameter of the power take-off of bell housing F is always the same as the diameter of the power take-off of bell housing A standard or strengthened version

<b>Forma costruttiva</b> Constructive forms	38	39	42	44	45	46	47	48	52	53	54	55	60	61	63	65	66	67
<b>Versione standard</b> Standard version																		
<b>Versione rinforzata</b> Strengthened version																		

QB

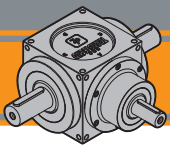

**Dimensioni**

**Dimensions**

**QB 350**

**Asse B-C integrale**

**B-C single output axis**

**Sporgente B-C**  
Protruding B-C

6.1  
mm

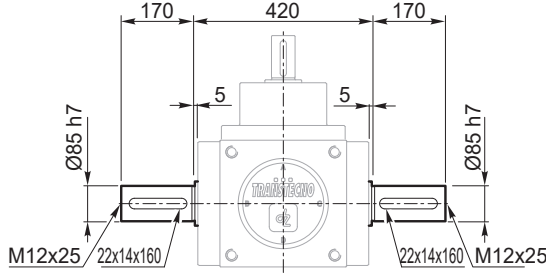
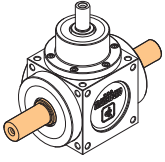

Forma costruttiva	1	6	11	16	40	43	48	62												
Constructive forms																				

**Sporgente B**  
Protruding B

6.2  
mm

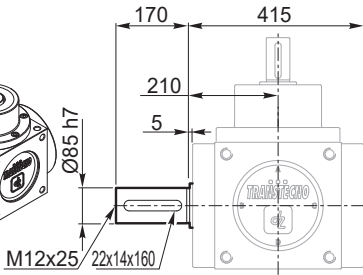
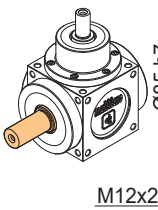

**Sporgente C**  
Protruding C

6.3  
mm

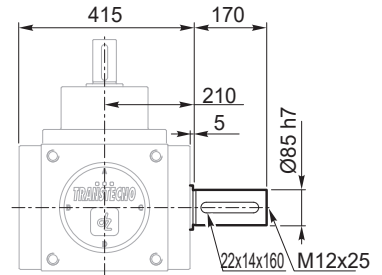
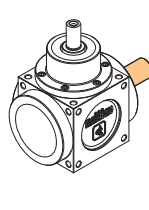

Forma costruttiva	2	7	12	17	41	44	46	68											
Constructive forms																			

Forma costruttiva	3	8	13	18	42	45	47	67										
Constructive forms																		

**Albero cavo con linguetta**  
Hollow shaft with key

6.4  
mm

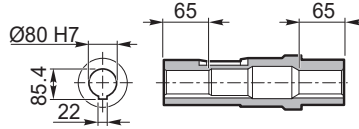
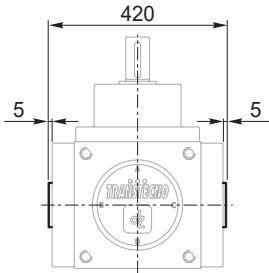
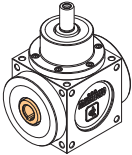

Forma costruttiva	4	9	14	19	34	36	38	60	61	64	65	66						
Constructive forms																		

**Albero cavo scanalato UNI 8953**  
Grooved hollow shaft UNI 8953

6.5  
mm

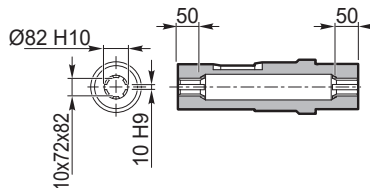
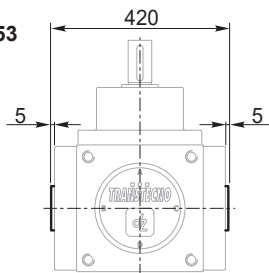
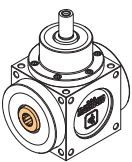

Forma costruttiva	5	10	15	20	35	37	39										
Constructive forms																	

**Albero cavo con calettatore**  
Hollow shaft with shrink disc

6.6  
mm

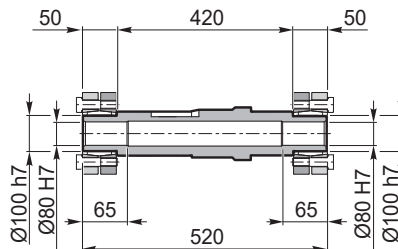
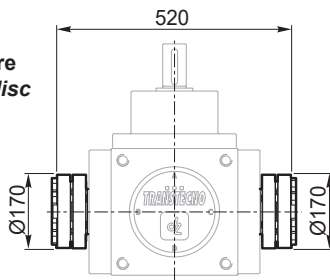
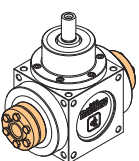

Forma costruttiva	21	22	23	24													
Constructive forms																	

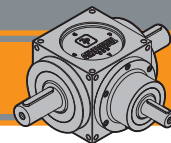

### Dimensioni

### Dimensions

## QB 350

### Asse B-C con Torrette

### Axis B-C with bell housing

#### Torrette B-C

#### Bell Housings B-C

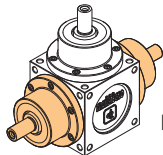

#### Versione standard Standard version

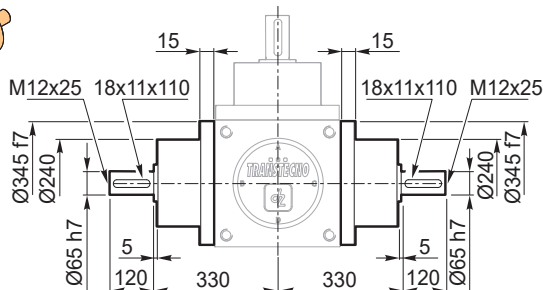

#### Versione rinforzata Strengthened version

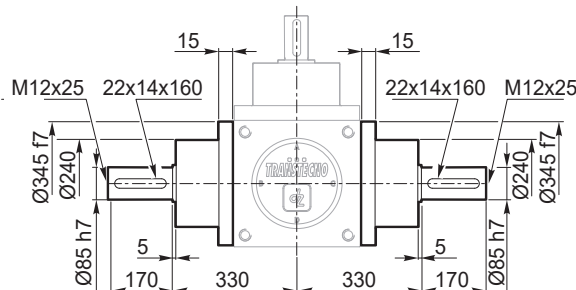

Forma costruttiva Constructive forms	28	29	30	31	32	33	49	53	55	57	59													
Versione standard Standard version																								
Versione rinforzata Strengthened version																								

Disponibile / Available

#### Torretta B

#### Bell housing B

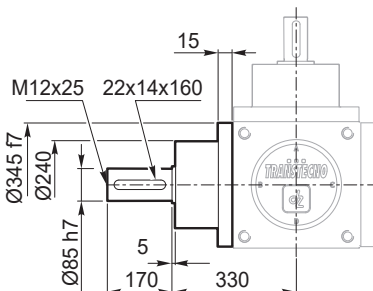
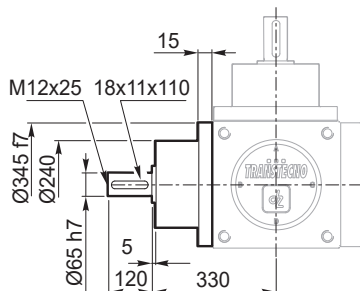
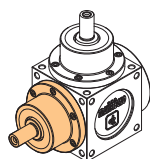

Forma costruttiva Constructive forms	25	26	27	50	51	52	54	56	58	63													
Versione standard Standard version																							
Versione rinforzata Strengthened version																							

Disponibile / Available

#### Torretta C

#### Bell housing C

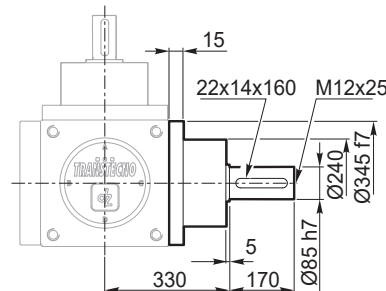
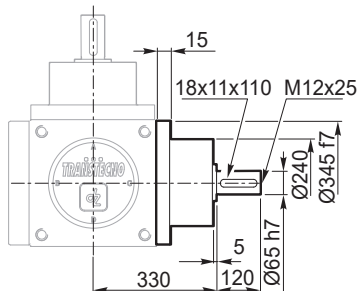
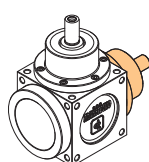

Forma costruttiva Constructive forms																							
Versione standard Standard version																							
Versione rinforzata Strengthened version																							

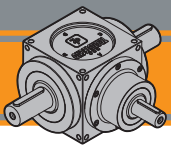

**QB**

Rinvii angolari  
Right-angle bevel gearboxes

## Note/Notes

---

---

---

---

---

---

---

---

---

---

---

---

---

---

---

---

---

---

---

---

---

---

---

---





**TRANSTECNO SRL  
HEADQUARTERS**

Company subject to the management  
and coordination of INTERPUMP GROUP SPA  
Via Caduti di Sabbiuno, 11/D-E  
40011 Anzola dell'Emilia (BO)  
ITALY  
T+39 051 64 25 811  
F +39 051 73 49 43  
sales@transtecno.com  
[www.transtecno.com](http://www.transtecno.com)

**TRANSTECNO®**  
the modular gearmotor

MEMBER OF INTERPUMP GROUP



**HANGZHOU TRANSTECNO POWER  
TRANSMISSIONS CO LTD**  
No.4 Xiuyan Road Fengdu Industry Zone  
Pingyao Town Yuhang District  
Hangzhou City, Zhejiang Province  
311115 – CHINA  
T +86 571 86 92 02 60  
info-china@transtecno.cn  
[www.transtecno.cn](http://www.transtecno.cn)



**MA TRANSTECNO S.A.P.I. DE C.V.**  
Av. Mundial # 176, Parque Industrial  
JM Apodaca, Nuevo León,  
C.P. 66600 - MÉXICO  
T +52 8113340920  
info@transtecno.com.mx  
[www.transtecno.com.mx](http://www.transtecno.com.mx)



**TRANSTECNO IBÉRICA  
THE MODULAR GEARMOTOR, S.A.**  
Carrer de la Ciència, 45  
08840 Viladecans (Barcelona) - SPAIN  
T +34 931 598 950  
info@transtecno.es  
[www.transtecno.es](http://www.transtecno.es)



**TRANSTECNO B.V.**  
Siliciumweg 32  
3812 SX Amersfoort - NETHERLANDS  
T +31(0) 33 45 19 505  
info@transtecno.nl  
[www.transtecno.nl](http://www.transtecno.nl)



**TRANSTECNO AANDRIJFTECHNIEK B.V.**  
Siliciumweg 32  
3812 SX Amersfoort - NETHERLANDS  
T +31(0) 33 20 47 006  
info@transtecnoaandrijftechniek.nl  
[www.transtecnoaandrijftechniek.nl](http://www.transtecnoaandrijftechniek.nl)



**TRANSTECNO USA**  
8 Creek Parkway,  
Boothwyn PA 19061-8136 - UNITED STATES  
T + 1 (610) 4970154

**TRANSTECNO USA – WEST COAST BRANCH**  
14561 Fryelands Blvd SE  
Monroe, WA 98272 - UNITED STATES  
T +1 360-863-1300  
usaoffice@transtecno.com  
[www.transtecno.com](http://www.transtecno.com)



**TRANSTECNO CANADA**  
51 B Caldari Road Unit 10  
Vaughan, ON L4K 4G3 - CANADA  
T +1 905 761 0762  
canadaoffice@transtecno.com  
[www.transtecno.com](http://www.transtecno.com)



**TRANSTECNO CHILE-PERU**  
Av. Los Libertadores 41  
Parque Industrial - Los Libertadores 16.500  
Santiago, Colina - CHILE  
T +56 2 29633870

Carretera Panamericana Sur KM 29.5,  
Interior I-3, Z.I. Lurin - PERU  
T +51 1 3546259 / + 51 1 3434231  
chileoffice@transtecno.com  
[www.transtecno.com](http://www.transtecno.com)



**TRANSTECNO INDIA**  
#6A, Sipcot Industrial complex, Phase-1, Elasagiri Road  
Hosur – 635126 Tamilnadu - INDIA  
T +91 4344 274434  
M +91 81443 88800

**TRANSTECNO INDIA – NORTH BRANCH**  
Plot No: 3 A, Sector 2, IIE, Sidcul, Pantnagar  
U.S. Nagar, Uttarakhand – 263153 - INDIA  
indiaoffice@transtecno.com  
[www.transtecno.com](http://www.transtecno.com)



**TRANSTECNO BRAZIL**  
Rua Gilberto de Zorzi, 525 Forqueta - CEP. 95115-730  
CX Postal 3544 Caxias do Sul RS – BRAZIL

**TRANSTECNO BRAZIL – SÃO PAULO BRANCH**  
R. Mafalda Barnabe Soliane, 314 – CEP. 13347-610  
Indaiatuba, São Paulo - BRAZIL  
T +55 19 3437 2520

**TRANSTECNO BRAZIL – PORTO ALEGRE BRANCH**  
Rua Dr. Freire Alemão 155 / 402 - CEP. 90450-060  
Auxiliadora Porto Alegre RS - BRAZIL  
T +55 51 3251 5447  
M +55 51 811 45 962  
braziloffice@transtecno.com  
[www.transtecno.com.br](http://www.transtecno.com.br)



**INTERPUMP ANTRIEBSTECHNIK - TRANSTECNO**  
Vertriebsbüro Stuttgart - GERMANY  
T +49 (0)171 4781909  
germanoffice@transtecno.com  
[www.transtecno.com](http://www.transtecno.com)



**SALES OFFICE OCEANIA**  
Unit 5, 12 Nyholt Drive, Yatala 4207  
Queensland - AUSTRALIA  
T +61 07 3800 0103  
M +61 04 38060997



UNIT 9, 94 Boundary Rd, Sunshine West 3020  
Victoria - AUSTRALIA  
T +61 9312 4722  
oceaniaoffice@transtecno.com  
[www.transtecno.com.au](http://www.transtecno.com.au)



**SALES OFFICE SOUTH KOREA**  
772-41, Bongdong-ro, Bongdong-eup, Wanju-goon  
Chonbuk, 55313  
SOUTH KOREA  
T +82 70 8867 8897  
M +82 10 5094 2107  
koreaoffice@transtecno.com  
[www.transtecno.com](http://www.transtecno.com)

[www.transtecno.com](http://www.transtecno.com)